

Great Plains

# PLANTER

## OPERATOR MANUAL

MODEL PL5700 3-Section Planter

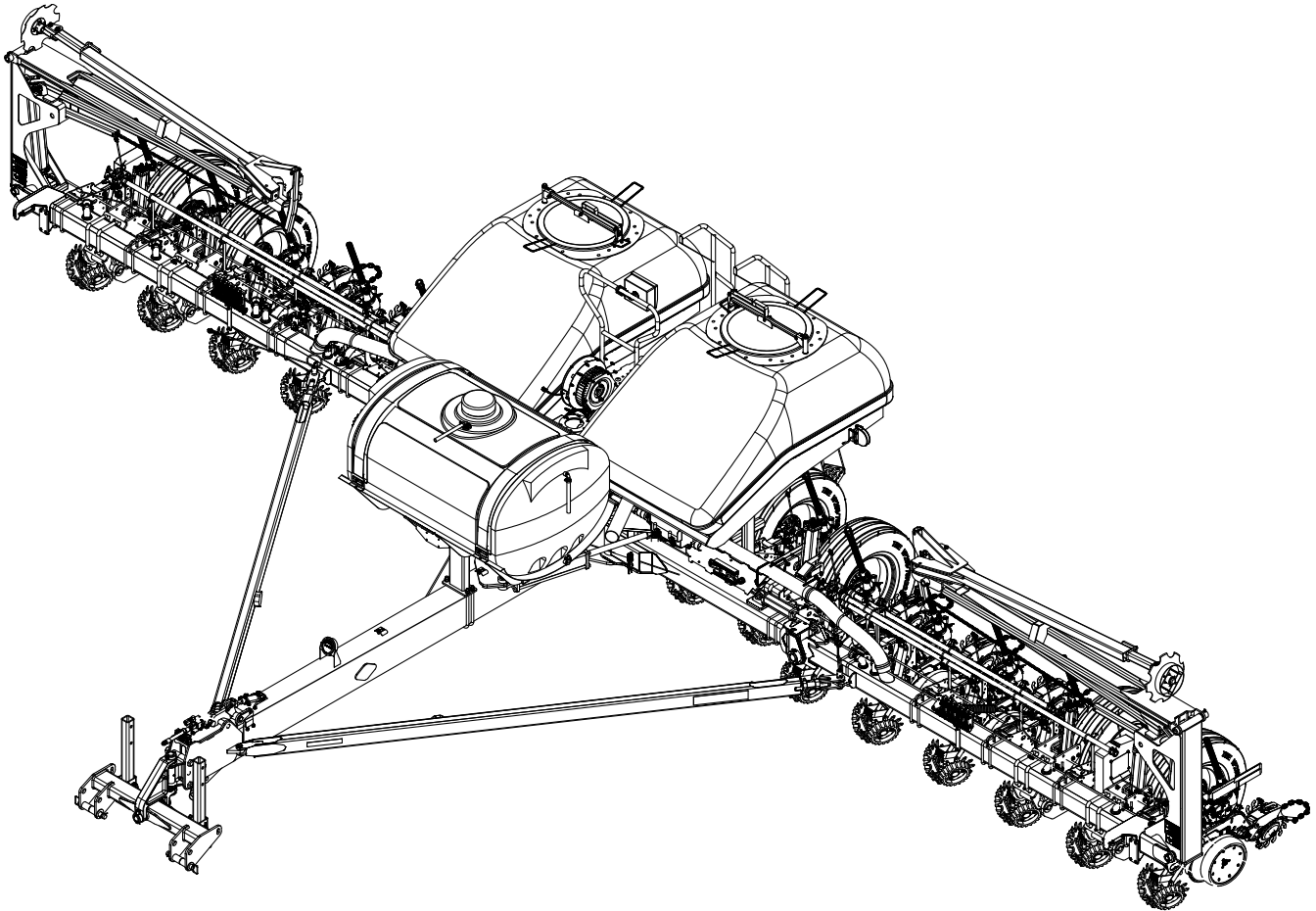

### Original Instructions 411-681M



*Read the operator manual entirely. When you see this symbol, the subsequent instructions and warnings are serious - follow without exception. Your life and the lives of others depend on it!*

*Illustrations may show optional equipment not supplied with standard unit.*

## Machine Identification

Record your machine details in the log below. If you replace this manual, be sure to transfer this information to the new manual.

If you or the dealer have added options not originally ordered with the machine, or removed options that were originally ordered, the weights and measurements are no longer accurate for your machine. Update the record by adding the machine weight and measurements with the option(s) weight and measurements.

<b>Model Number</b>	
<b>Serial Number</b>	
<b>Machine Height</b>	
<b>Machine Length</b>	
<b>Machine Width</b>	
<b>Machine Weight</b>	
<b>Year of Construction</b>	
<b>Delivery Date</b>	
<b>First Operation</b>	
<b>Accessories</b>	<hr/> <hr/> <hr/>

## Dealer Contact Information

**Name:** \_\_\_\_\_

**Street:** \_\_\_\_\_

**City/State:** \_\_\_\_\_

**Telephone:** \_\_\_\_\_

**Email:** \_\_\_\_\_

**Dealer's Customer No.:** \_\_\_\_\_

California Proposition 65
 <b>WARNING:</b> Handling passenger or off-highway motor vehicle parts can expose you to chemicals such as phthalates and lead, which can cause cancer and reproductive harm. To minimize exposure, service the vehicle in a well-ventilated area, wear gloves, and wash your hands. For more information see <a href="http://www.P65Warnings.ca.gov/motor-vehicle-parts">www.P65Warnings.ca.gov/motor-vehicle-parts</a> .

To our customer:

Congratulations on the purchase of your Great Plains product. Great Plains welcomes you to its growing family of new product owners. Your product has been designed and built by skilled workers using quality materials.

Your dealer has performed the necessary pre-delivery service to your machine, and will advise you of the proper maintenance and operating practices that will give you long, satisfactory use of your machine. Do not hesitate to contact your dealer when you have a question related to your machine.

Your machine has been designed to run efficiently in most operating conditions, and will perform relative to the service it receives. If you need customer service or repair parts, contact your dealer who has trained personnel, repair parts, and equipment specially designed for Great Plains products.

Read this manual carefully before using the machine. It will familiarize you with safety, operation, adjustments, and maintenance of your new equipment. This manual must always be kept with your machine.

Great Plains wants you to be satisfied with your product. If for any reason you do not understand any part of this manual or are otherwise dissatisfied, please take the following actions first:

1. Discuss the matter with your dealership service manager. Make sure he is aware of any problems so he can assist you.
2. If you are still unsatisfied, seek out the owner or general manager of the dealership.

If your dealer is unable to resolve the problem or the issue is parts related, please contact:

Great Plains Service Department  
1525 E. North St.  
P.O. Box 5060  
Salina, KS, USA 67402-5060

*Printed 01/08/2026 | English*

*Great Plains reserves the right to revise and improve its products at any time. This publication describes the state of this product at the time of its publication, and may not reflect the product in the future. The content of this publication may be changed without notice.*

© 2021 Great Plains | Printed in the United States of America

All rights reserved. No part of this publication may be reproduced, distributed, or transmitted in any form or by any means, including photocopying, recording, or other electronic or mechanical methods, without the prior written permission of the publisher, except in the case of brief quotations embodied in critical reviews and certain other noncommercial uses permitted by copyright law.

Trademarks of Great Plains Manufacturing, Inc. include: AccuShot, DrillCommand, Max-Chisel, Row-Pro, Singulator Plus, Short Disk, Swath Command, Terra-Tine, Ultra-Chisel, and X-Press.

Registered trademarks of Great Plains Manufacturing, Inc. include: Air-Pro, Clear-Shot, Discovator, Great Plains, Land Pride, MeterCone, Nutri-Pro, Seed-Lok, Solid Stand, Terra-Guard, Turbo-Chisel, Turbo-Chopper, Turbo-Max, Turbo-Trill, Ultra-Till, Whirlfilter, and Yield-Pro.

Brand and product names that appear and are owned by others are trademarks of their respective owners.

For permission requests, write to the publisher at the address below.

Great Plains Mfg.  
1525 E. North St.  
P.O. Box 5060  
Salina, KS 67402

You can also visit our website at [www.greatplainsag.com/en/manuals/905/product-manuals](http://www.greatplainsag.com/en/manuals/905/product-manuals) for a full catalog of this and other manuals.

Ordering Information:

Quantity sales. Special discounts are available on quantity purchases by corporations, associations, and others. For details, contact the publisher at the address above.

Orders for personal, non-commercial use. Please contact our service department by mail or our website [www.greatplainsag.com](http://www.greatplainsag.com).

# Table of Contents

<b>Introduction</b> .....	<b>1</b>	Liquid Fertilizer Pump (Option) .....	17
Intended Use Statement .....	1	<b>Operation</b> .....	<b>18</b>
Prohibited Use .....	1	Pre-Start Checklist .....	18
Machine Identification .....	1	Field Operation .....	18
Target Group for Operator Manual .....	1	Before Planting Checklist .....	18
Training and Instruction .....	1	Begin Planting .....	18
<b>Safety Information</b> .....	<b>2</b>	End Planting .....	18
Safety Symbols and Signal Words .....	2	Transport Locks .....	19
Observe Safety and Informational Symbols ..	2	Wing Hooks .....	19
Be Aware of Signal Words .....	2	Cylinder Locks .....	19
Before Getting Started .....	2	Tongue Hook Latch .....	20
Read Machine Information .....	2	Operation Controls .....	20
Wear Appropriate Clothing and Equipment ..	2	IntelliAg ISO6 .....	20
Inspect Machine Before Use .....	2	PL5700 Switch Box .....	20
Machine Use .....	3	Raising/Lowering Tongue .....	20
Operate Responsibly .....	3	Raising/Lowering Wing Gauge Wheels .....	20
Handle Hydraulics with Care .....	3	With IntelliAg ISO6 .....	20
Avoid Potential Collision Damage .....	3	With Switch Box .....	21
Chemicals and Waste .....	3	Raising the Planter .....	21
Dispose of Waste Properly .....	3	With IntelliAg ISO6 .....	22
Machine Maintenance .....	4	With Switch Box .....	22
Follow Tire Recommendations .....	4	Lowering the Planter .....	22
Prepare for Performing Maintenance .....	4	With IntelliAg ISO6 .....	23
PTO .....	4	With Switch Box .....	23
Machine Transport .....	4	Field Position .....	23
Use Safety Lights and Devices .....	4	Unfolding .....	23
Shutdown and Storage .....	4	With IntelliAg ISO6 .....	23
<b>Safety Decals</b> .....	<b>5</b>	With Switch Box .....	24
<b>Preparation and Setup</b> .....	<b>12</b>	Folding .....	25
Preparation Checklist .....	12	With IntelliAg ISO6 .....	26
Hitch Planter to Tractor .....	12	With Switch Box .....	27
Hydraulic Hose Connections .....	12	Markers (Option) .....	28
Fan Hydraulic Connections .....	12	With IntelliAg ISO6 .....	28
Electrical Connections .....	13	With Switch Box .....	28
Two-Point Hitch .....	13	Operational Sequence - Dual Markers .....	29
Weight Transfer System (Option) .....	13	Ground Drive Section Control (Option) .....	29
Rephasing Hydraulics .....	14	With Switch Box .....	29
Planter Leveling .....	15	Swath Command™ (Option) .....	29
Speed Calibration .....	15	Air System - Bulk Seed Hoppers .....	30
Speed Sensor .....	15	Seed Delivery Air Flow .....	30
Markers .....	16	Seed Meter Air Flow .....	31
<b>Marker Extension Length</b> .....	<b>16</b>	Fan Hydraulics - Bulk Seed Hoppers .....	32
Marker Chain Length .....	17	Tractor Connections .....	32
<b>Marker Disk Angle</b> .....	<b>17</b>	Fan Hydraulic Hoses .....	32
Bulk Hopper Level Sensors (Option) .....	17	Air System - Row Hoppers .....	33
Rear Auxiliary Hydraulics (Option) .....	17	Fan Hydraulics - Row Hoppers .....	34
		Tractor Connections .....	34

Fan Hydraulic Hoses . . . . .	34	Loading Materials . . . . .	55
Fan Operation . . . . .	34	Orifice Plates . . . . .	55
Fan Adjustment . . . . .	35	Orifice Plate Installation . . . . .	56
Adjusting for Skips . . . . .	36	Strainer . . . . .	56
Adjusting for Doubles . . . . .	36	Relief Valve . . . . .	56
Fine-Tune Meter Pressurization . . . . .	36	Setting Fertilizer Rate . . . . .	57
Alternate Skips/Doubles Check . . . . .	37	Fertilizer Ground Drive . . . . .	57
Baffle Adjustment . . . . .	37	Fertilizer Hydraulic Drive . . . . .	57
PM300 Seed Monitoring System (Option) . . . . .	37	AccuShot Fertilizer System (Option) . . . . .	58
Seed Lubricants . . . . .	38	Fertilizer Section Control System (Option) . . . . .	58
Ezee Glide Plus . . . . .	38	Parking . . . . .	58
Bayer Fluency Agent Advanced . . . . .	38	Transport . . . . .	59
Rear Auxiliary Hydraulics (Option) . . . . .	39	<b>Maintenance . . . . .</b>	<b>60</b>
Material Loading . . . . .	39	Maintenance Schedule . . . . .	60
Bulk Seed Hoppers . . . . .	39	Regular Maintenance . . . . .	60
Row Hoppers . . . . .	39	Hydraulic System . . . . .	61
Seed Meter Setup and Adjustments . . . . .	40	Hydraulic System Inspection . . . . .	61
Seed Meter Rain Cover . . . . .	40	Hydraulic Drive . . . . .	61
Seed Disk Installation . . . . .	40	Hydraulic Drive Filter . . . . .	61
Seed Disk Removal . . . . .	41	Markers . . . . .	61
Seed Inlet Gate Adjustment . . . . .	41	Marker Shear Bolt . . . . .	61
Seed Pool Slopes . . . . .	42	Marker Disk Lubrication . . . . .	62
Seed Meter Operation . . . . .	42	In-Cab Consoles . . . . .	62
Hydraulic Drive . . . . .	43	Material Clean-Out . . . . .	62
Setting Planting Rate . . . . .	43	Bulk Seed Hopper Clean-Out . . . . .	62
Ground Drive Planters . . . . .	43	Air Box Clean-Out . . . . .	63
Contact Drive Wheel . . . . .	44	Air System Clean-Out . . . . .	63
Travel Distance . . . . .	44	Air Box Residue Clean-Out . . . . .	63
Hydraulic Drive or IRC Planters . . . . .	45	Meter Clean-Out Container . . . . .	64
Check Planting Rate . . . . .	45	Meter Clean-Out . . . . .	64
Height Switch . . . . .	46	Alternate Meter Clean-Out . . . . .	65
5000 Series Row Unit . . . . .	46	Seed Tube Clean-Out . . . . .	65
Row Unit Down Pressure . . . . .	47	Fertilizer Tank Clean-Out . . . . .	65
Down-Pressure Adjustment . . . . .	47	Seed Meter Brushes . . . . .	65
Row Unit Opener Disks . . . . .	49	Seed Meter Brush Replacement . . . . .	66
Planting Depth . . . . .	49	Seed Disk Maintenance . . . . .	68
Disk Contact Adjustment . . . . .	49	Cleaning and Storing Seed Disks . . . . .	68
Side Depth Wheel Adjustments . . . . .	49	Chains . . . . .	68
Depth Wheel Scrapers (Option) . . . . .	50	Chain Lubrication . . . . .	68
Press Wheel Adjustments . . . . .	51	Chain Slack . . . . .	68
Down Pressure . . . . .	51	Chain Clips . . . . .	68
Press Wheel Stagger . . . . .	51	Seed Meter Drive Chain . . . . .	69
Press Wheel Centering . . . . .	51	Side Depth Wheels . . . . .	69
Unit Mount Row Cleaners (Option) . . . . .	52	Disk Separators and Scrapers . . . . .	69
Unit Mount Coulters (Option) . . . . .	53	Seed Flap Replacement . . . . .	70
Coulter Row Alignment . . . . .	54	Fertilizer System . . . . .	70
Seed Firmer (Option) . . . . .	54	Liquid Fertilizer Strainer . . . . .	70
Keeton® Seed Firmer . . . . .	54	Lubrication . . . . .	71
Swath Command™ (Option) . . . . .	55	Grease Fittings . . . . .	71
Liquid Fertilizer (Option) . . . . .	55		

Bearings . . . . .	71	<b>Specifications . . . . .</b>	<b>94</b>
Storage . . . . .	72	Transport Dimensions . . . . .	98
Inside Disk Scraper Installation . . . . .	72	Bulk Hopper Planters . . . . .	98
<b>Troubleshooting . . . . .</b>	<b>74</b>	<b>Row Hopper Planters . . . . .</b>	<b>100</b>
Seed Pool Troubleshooting . . . . .	74	Field/Working Dimensions . . . . .	101
Bulk Hopper Planters . . . . .	75	Hydraulic Diagrams . . . . .	105
Row Hopper Planters . . . . .	77	Lift Hydraulics - 12 Row Planters . . . . .	105
Seed Pool Recovery . . . . .	78	Lift Hydraulics - 16 Row Planters . . . . .	106
Seed Population Troubleshooting . . . . .	78	Fold Hydraulics . . . . .	107
Seed Population Too Low . . . . .	80	Dual Fan Hydraulics - Bulk Hopper . . . . .	108
Seed Population Too High . . . . .	82	Single Fan Hydraulics - Row Hopper . . . . .	109
Seed Delivery Problems - Bulk Seed . . . . .	83	Marker Hydraulics . . . . .	110
Planter Troubleshooting . . . . .	83	Weight Transfer Hydraulics . . . . .	111
Fertilizer Troubleshooting . . . . .	85	Liquid Fertilizer Plumbing Diagrams . . . . .	112
Topcon Console Troubleshooting . . . . .	86	30" Row Spacing Plumbing (S/N E1008B-) . . . . .	112
<b>Options . . . . .</b>	<b>87</b>	30" Row Spacing Plumbing (S/N E1009B+) . . . . .	113
Rear Auxiliary Hydraulics . . . . .	87	70 cm Row Spacing Plumbing . . . . .	114
Swath Command . . . . .	87	Fuse Box Diagrams . . . . .	115
Topcon Console System . . . . .	87	12-and-16 Row with Switch Box . . . . .	115
Dickey-john PM300 with Switch Box . . . . .	87	12 Row with IntelliAg ISO6 . . . . .	115
Bulk Seed Scale Option . . . . .	88	16 Row with IntelliAg ISO6 . . . . .	116
Bulk Hopper Seed Sensor . . . . .	88	IRC . . . . .	116
Weight Transfer System . . . . .	88	Topcon XD and XD-Plus . . . . .	117
Rear Hitch Assembly . . . . .	88	Torque Value Chart . . . . .	118
Keeton® Seed Firmer . . . . .	88	Tire Information . . . . .	118
Fertilizer System . . . . .	89	<b>Pre-Delivery Instructions . . . . .</b>	<b>119</b>
Fertilizer Tanks . . . . .	89	Requirement Checklist . . . . .	119
Fertilizer Orifice Plates . . . . .	89	Tools Required . . . . .	119
Fertilizer Dribblers . . . . .	89	Unloading Planter . . . . .	119
Fertilizer Flow Sensor . . . . .	89	With IntelliAg ISO6 . . . . .	120
VeriFlow Nozzles . . . . .	90	With Switch Box . . . . .	121
VisaGage II (S/N E1008B-) . . . . .	90	Shipping Check Valve Removal . . . . .	122
VisaGage II (S/N E1009B+) . . . . .	90	With IntelliAg ISO6 . . . . .	122
VisaGage II (S/N E1009B+) . . . . .	90	With Switch Box . . . . .	124
Fertilizer Hydraulic Drive . . . . .	90	Shipping Chain Removal . . . . .	125
Fertilizer Ground Drive . . . . .	90	Close-Out . . . . .	125
Seed Lubricant . . . . .	91	<b>Trailer Shipping . . . . .</b>	<b>126</b>
Unit Mount Row Cleaners . . . . .	91	Shipping Chain Installation . . . . .	126
Unit Mount Row Cleaner (UMRC) . . . . .	91	With IntelliAg ISO6 . . . . .	126
Unit Mount Coulter Row Cleaner . . . . .	91	With Switch Box . . . . .	127
Unit Mounted Disk Coulters . . . . .	91	Shipping Check Valve Kit Installation . . . . .	129
Coulter Blades . . . . .	91	With IntelliAg ISO6 . . . . .	129
Inside Disk Scrapers . . . . .	91	With Switch Box . . . . .	131
Row Unit Press Wheels . . . . .	91	Close-Out . . . . .	132
Side Depth Wheel Scrapers . . . . .	91	Loading Planter on Trailer . . . . .	132
Seed Meter Clean-Out Container . . . . .	92	With Switch Box . . . . .	133
Seed Tube Brush . . . . .	92	Unloading from Trailer . . . . .	134
Seed Meter Disks . . . . .	92	With IntelliAg ISO6 . . . . .	134
SureForce Hydraulic Option . . . . .	93	With Switch Box . . . . .	135

Shipping Check Valve Removal . . . . .	136
With IntelliAg ISO6 . . . . .	137
With Switch Box . . . . .	138
Shipping Chain Removal . . . . .	139
Close-Out . . . . .	139

## Introduction

The Great Plains PL5700 Planter is a pull-type implement with optional mounted fertilizer capability. The planter is front-fold for transport. The planter includes 5000 Series openers with Air-Pro® meters. Optional unit-mounted coulters are available for light to moderate no-till conditions. The seed metering system can be ground drive, hydraulic drive, or electric drive.

### ■ Intended Use Statement

The PL5700 Planter with standard equipment and/or authorized attachments and options is intended to be used as a seeding/fertilizing machine when operated according to instructions and safety precautions in this manual, machine decals, or other information provided with the machine.

Use this planter to seed and fertilize production-agriculture crops only. It is suitable for conventional till, min-till, and moderate no-till conditions.

Any other use, for example, using the machine as a grader or cultivator tool, is not permitted. The manufacturer and dealers are not liable for damage caused by improper use.

### Prohibited Use

Do not use this machine for any purpose or in any way other than what is described in this manual, machine decals, or any other information provided with the machine by the manufacturer. These materials define the intended use of the machine.

Unauthorized modifications to the machine will relieve the manufacturer of all liability for any resulting injury or damage.

### ■ Machine Identification

Your machine's parts were specially designed and should only be replaced with Great Plains parts. Always use the serial and model number when ordering parts from your dealer. Record your planter model and serial number on the inside cover of this manual for quick reference.

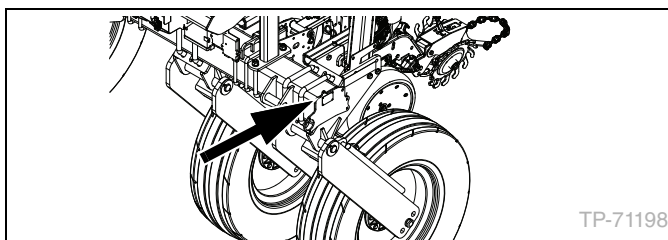

### ■ Target Group for Operator Manual



#### Simplified Illustrations

*Illustrations of the machine in the operator manual are shown without protective equipment - or with the protective equipment open - for better understanding. Be sure to observe the safety information and follow the handling instructions in the operator manual. Serious or fatal injury may be caused as a result.*

This operator manual is aimed at trained agriculturists and persons who are otherwise qualified for agricultural activities and have received instruction in working with this machine.

**For your safety** - You must familiarize yourself with the contents of this operator manual before assembly or initial operation of the machine. In this way, you will achieve optimum work results and operational safety. The operator manual forms an integral part of the machine and must always be kept at hand. This will ensure that you:

- avoid accidents.
- comply with warranty conditions.
- have a fully functional machine in good working order at all times.

### Training and Instruction

Your dealer will provide instruction on operation and care of the machine.

**Information for the employer** - All personnel are to be regularly, at least once a year, instructed on the use of the machine, in accordance with the regulations of the national organization for Health and Safety at Work. Untrained or unauthorized persons are not permitted to use the machine.

You are responsible for ensuring that the machine is operated and maintained safely. Ensure you and all other persons that operate, maintain, or work in close proximity with the machine are familiar with the operating and maintenance regulations, as well as

the corresponding safety instructions in this operator manual.



**Parts Manual QRC**

The QR Code to the left will take you to this machine's parts manual. Use your smart phone or tablet to scan and start viewing.



**Product Manuals QRC**

The QR Code to the left will take you to Great Plains' catalog of product manuals. Use your smart phone or tablet to scan and start viewing.

## Safety Information

### ■ Safety Symbols and Signal Words

#### Observe Safety and Informational Symbols

Throughout this manual you will see the following safety and informational symbols. They indicate safety hazards, machine hazards, or information to improve operation. Read the instructions carefully whenever you see any of these symbols:



The safety symbol indicates a potential safety hazard to persons operating or near the machine and advises on how to avoid it.



The notice symbol indicates a potential for machine or property damage from operator error and advises on how to avoid misuse.



The information symbol indicates useful - but not crucial - information for machine operation, assembly, or adjustment.

#### Be Aware of Signal Words

Some decals are accompanied by a signal word. Signal words indicate the seriousness of a potential hazard. These signal words are:

#### **⚠ DANGER**

DANGER indicates an imminent hazard which, if not avoided, will result in death or serious injury. This signal word is limited to the most serious situations, typically for unguarded machine components.

#### **⚠ WARNING**

WARNING indicates a potential hazard which, if not avoided, could result in death or serious injury including hazards that are exposed when guards are removed. It also alerts against unsafe practices.

#### **⚠ CAUTION**

CAUTION indicates a potential hazard, which if not avoided, may result in minor or moderate injury. It also alerts against unsafe practices.

### ■ Before Getting Started

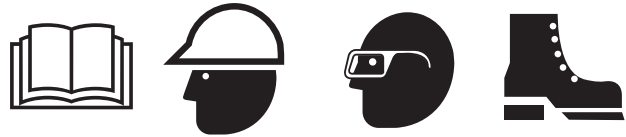

#### Read Machine Information

- Read this manual in its entirety before attempting to start and operate the machine. Do not let anyone operate machine without proper instruction.
- Non-Great Plains components on this machine may contain additional safety information not found in this manual. Consult the manufacturer's safety information and product decals to safely use products from third-parties.

#### Wear Appropriate Clothing and Equipment

- Never wear loose clothing around machine. Always wear appropriate clothing and equipment such as hard hats, gloves, face masks, eye protection, and work or steel-toed boots as needed.
- Prolonged exposure to machine noise during operation can cause hearing impairment or loss. Use proper hearing protection like earmuffs or earplugs while working.

#### Inspect Machine Before Use

- Inspect brakes, link pins, and other mechanical parts for wear and dirt buildup, and check that all guards and shields are undamaged, installed, and secure before operating machine.
- Check that hydraulic fittings are tight and all hydraulic hoses and lines are in good working condition before applying pressure to the system.
- Do not modify the machine. Unauthorized modification can result in unsafe conditions that lead to machine damage or personal injury.

## ■ Machine Use



### Operate Responsibly

- Maintain attention on operation at all times to avoid injury to yourself or others.
- Do not operate machine while distracted by a smart phone, tablet, or similar electronic device, or while impaired by alcohol, medication, any controlled substance, or while fatigued.
- Do not ever allow passengers to ride on any part of the machine at any time, for any reason.

### Handle Hydraulics with Care

- Keep clear of machine while hydraulics are in use. Any failure in the hydraulic system can cause machine parts to move or fall rapidly with a great deal of force. Anyone struck, caught between, or crushed beneath these parts can suffer serious injury or even death.
- A raised planter without cylinder locks installed or without active hydraulic pressure will slowly lower over time. Use tractor hydraulics to raise planter only for brief periods, such as field turns and cylinder lock installation.
- Relieve hydraulic pressure and wait for all parts to come to a complete stop before disconnecting any hydraulic lines or performing any work on the hydraulic system.
- Do not have skin exposed when searching for leaks in hydraulic lines. Use a piece of cardboard or wood to locate leaks. If injured by escaping hydraulic fluid, seek immediate medical attention.
- Wear protective gloves and eye protection when working on the machine's hydraulic system.

### Avoid Potential Collision Damage

- Watch your surroundings at all times. Do not operate with nearby bystanders or while anyone makes adjustments or fills the machine.
- Avoid contacting overhead obstructions such as low bridges, overpasses, and power lines.
- Do not operate near ditches, holes, steep slopes, embankments, or other surfaces which may collapse under the machine's weight or tip the machine over.

## ■ Chemicals and Waste



Agricultural chemicals can be dangerous. Improper use can seriously injure persons, animals, plants, soil and property.

- Read chemical manufacturer's instructions carefully, and then take appropriate precautions before use. In the absence of manufacturer instructions, chemical labels will inform you of any potential hazards and their severity.
- Wear protective clothing and as well as any other personal protective equipment.
- Wash hands and face before eating after working with chemicals. Shower as soon as application is completed for the day.
- Apply only with acceptable wind conditions. Make sure wind drift of chemicals will not affect any surrounding land, people or animals.
- Dispose of unused chemicals and chemical waste as specified by the manufacturer. Observe all the local ordinances and regulations in your area.

### Dispose of Waste Properly

- Dispose of waste properly to avoid threatening the environment and ecology. Potential harmful waste includes oil, fuel, filters, and batteries.
- Use a leak-proof container for draining fluids. Do not use a food or beverage container that may be mistaken for a consumable product.
- Do not drain or pour waste onto the ground, down a drain, or into any water source.
- Contact your local environmental or recycling center for the proper way to recycle or dispose of waste.

## ■ Machine Maintenance



### Follow Tire Recommendations

- Consult the tire manufacturer's recommendations for maintenance and replacement of your machine's tires. Only use prescribed tire sizes with correct ratings and tire pressure.
- Replacing tires is potentially hazardous. Have a trained professional change the machine's tires with the proper tools and equipment.
- Avoid over inflation of tires and over torquing wheel bolts. Review the machine specifications and tire information in this manual first before doing any work on the tires of your machine.

### Prepare for Performing Maintenance

- Understand procedure before performing any work. Always use proper tools and equipment.
- Only work on or around the machine if frame is lowered, or raised with the cylinder locks in place.
- Lower the implement. Put tractor in Park, turn off engine. To prevent unauthorized starting, remove key before performing maintenance or service work.
- If work must be performed with wings raised, set the wing tilt locks to the road position.
- Disconnect electronic monitor and lighting harness from the tractor before servicing or adjusting electrical systems.
- Check and replace worn brake lines as needed.
- Remove all tools and unused parts from implement before operation.

### PTO



- Wait until all moving components have completely stopped before adjusting, cleaning, or servicing any PTO driven equipment.
- When operating stationary PTO driven equipment, always apply the parking brake and place chocks behind wheels.
- Stay clear of and never step over any rotating parts.

## ■ Machine Transport

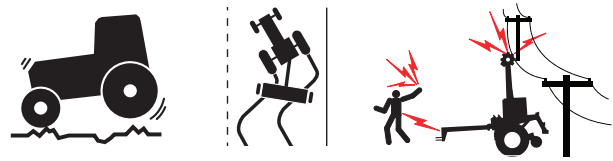

- This machine does not meet all local, regional, or national regulations for transport on a public road. Know and comply with your local laws and regulations before transporting your machine.
- Transport only at recommended transport speed. Further reduce speed when turning.
- Before towing implement on roads, empty out all material from hoppers or boxes. Implement should never weigh more than 1.5 times the weight of towing vehicle.
- Know transport height and width of implement to avoid collision.
- Do not engage any hydraulic functions while machine is in transport.

## ■ Use Safety Lights and Devices



- Inspect safety chain and chain load rating before use with machine. Never use the safety chain for towing. Replace chain if any links or end fittings are broken, stretched, or otherwise damaged.
- Always use safety lights and devices when transporting and operating the machine. If equipped, use flashing warning lights and turn signals whenever driving on public roads.
- Regularly inspect safety lights, signs, and devices to ensure that they are clean and visible from either end of the machine.

## ■ Shutdown and Storage

- Park the tractor and implement on a solid, level surface devoid of bystanders.
- Fold and tilt wings up.
- Put tractor in park or set the parking brake. Turn off engine and remove key from ignition.
- Turn lockout valve and wing lock levers to locked position to prevent the wings from lowering.
- Detach the tractor. Secure the implement using blocks.

# Safety Decals

Your implement comes equipped with safety reflectors and decals in place.

Read and follow decal directions. Keep all safety decals clean and legible. Replace all damaged, faded, or missing decals.

Order new decals from your Great Plains dealer. Refer to this section for proper decal placement.

When ordering new parts or components, also request corresponding safety decals.

To install new decals:

- Clean the area on which the decal is to be placed.
- Peel backing from decal. Press firmly on surface, being careful not to cause air bubbles under decal.

## Slow Moving Vehicle Reflector

818-055C



Bulk seed hoppers - One reflector at rear of hoppers.

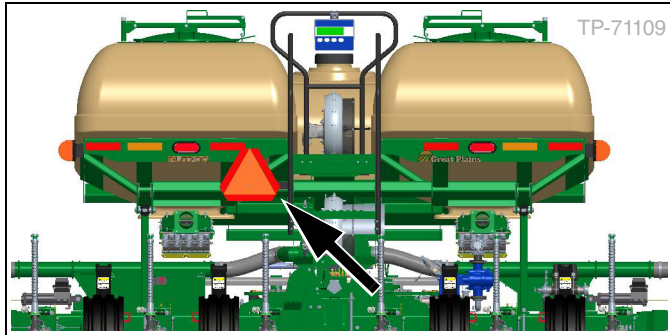

Row hopper planters - One reflector on rear of fan.

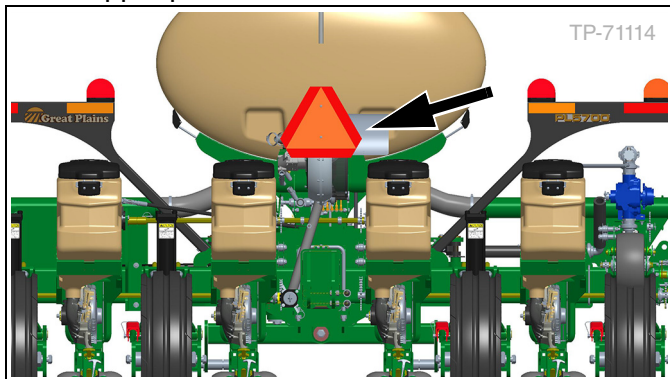

## Red Reflectors

838-614C



Bulk seed hoppers, four reflectors - Two reflectors under each hopper.

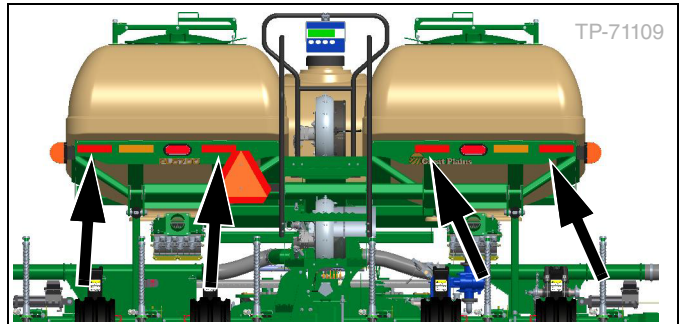

Row hopper planters, two reflectors - One reflector on the end of each light bracket.

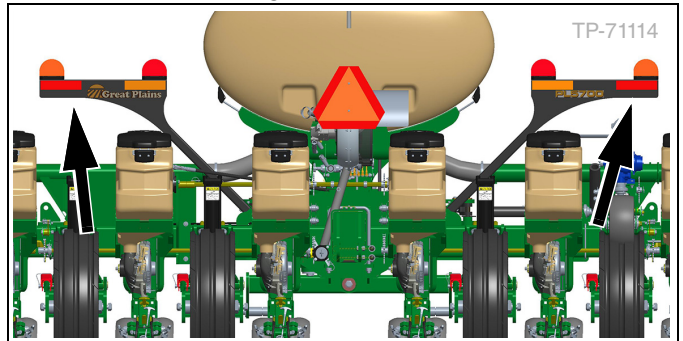

## Amber Reflectors

838-615C



Bulk seed hoppers, two reflectors - One reflector on rear of each wing to face out when planter is folded.

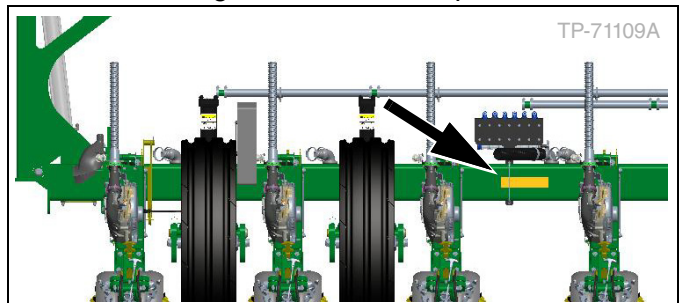

Bulk seed hoppers, four reflectors - One reflector on end of each wing to face front when folded, and one on each outside wheel mount of center section.

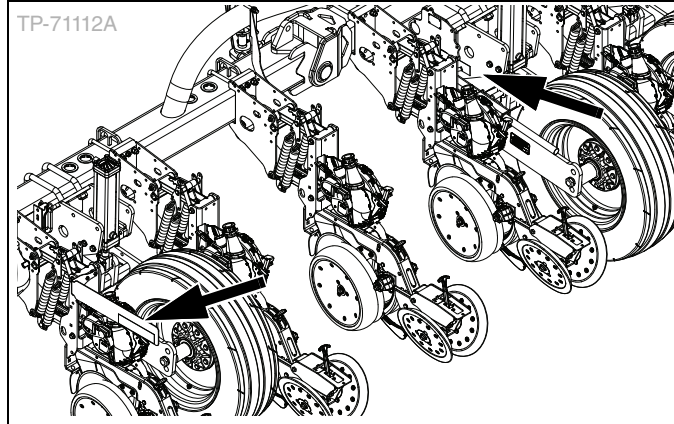

Row hopper planters, two reflectors - One reflector on rear of each wing to face out when planter is folded.

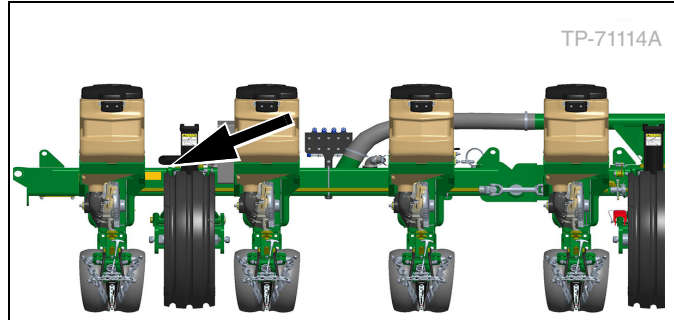

Row hopper planters, four reflectors - One reflector on each end hopper mount to face front when folded, and one on each outside wheel mount of center section.

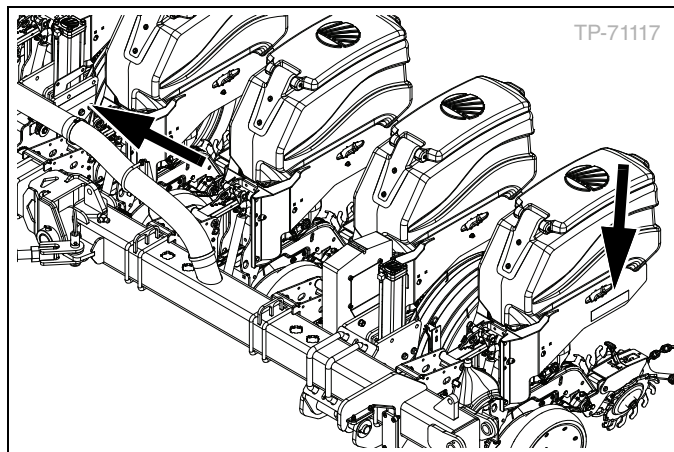

**Orange Reflectors**

838-603C



Bulk seed hoppers, two reflectors - One reflector under each hopper.

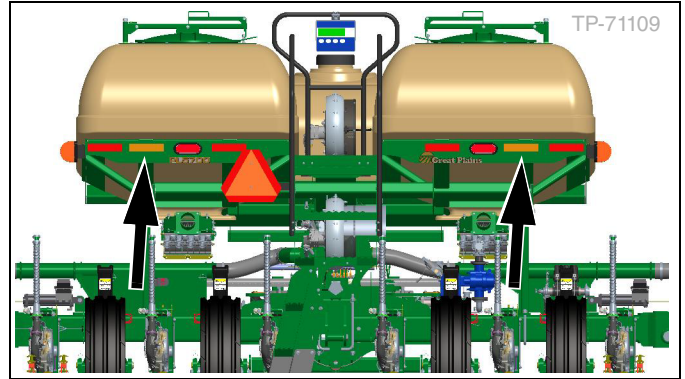

Row hopper planters, two reflectors - One reflector on each light bracket.

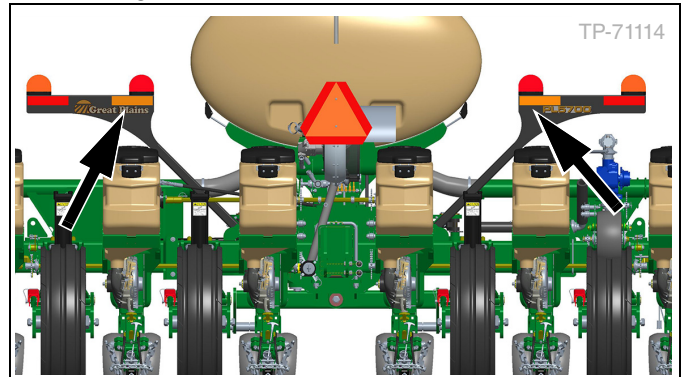

Excessive Speed Hazard

818-188C



One decal - On left front of tongue.

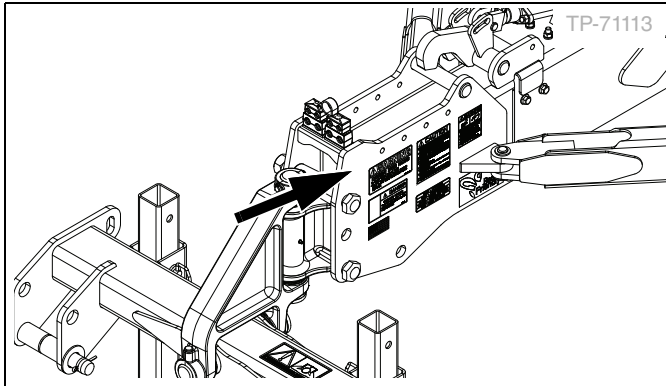

1000 rpm PTO (Option)

818-240C



One decal - On front of PTO hydraulic reservoir.

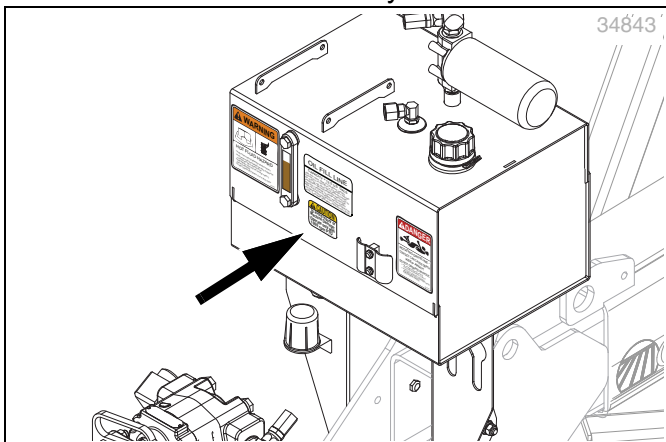

High Pressure Fluid Hazard

818-339C



One decal - On left front of tongue.

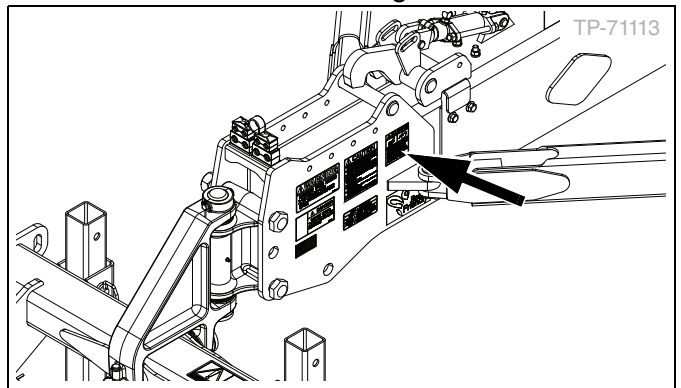

Falling Hazard

818-398C



Two or four decals - On hydraulic cylinder of each wing gauge wheel assembly.

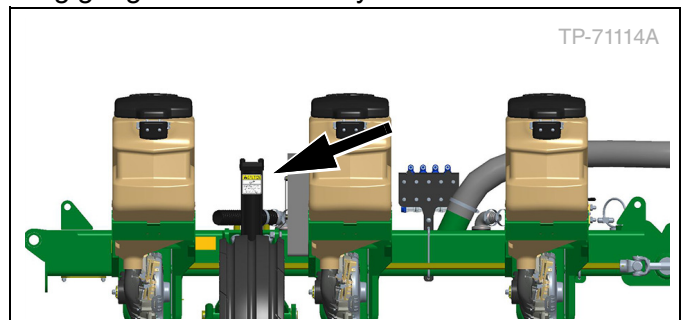

**Sharp Object Hazard**

818-525C



One decal - On each row cleaner.

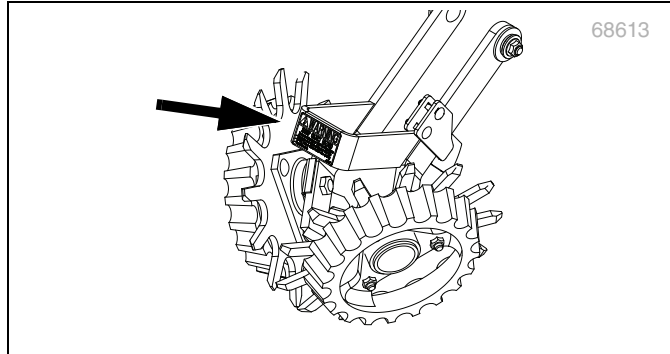

**Electrocution Hazard**

838-599C

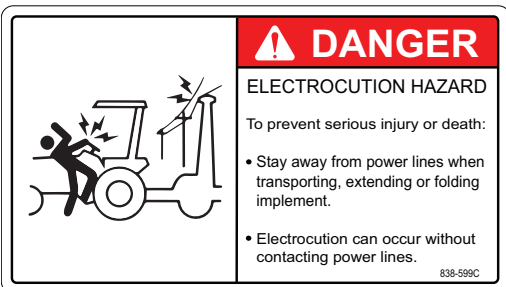

Two decals - On each marker first section; top decal.

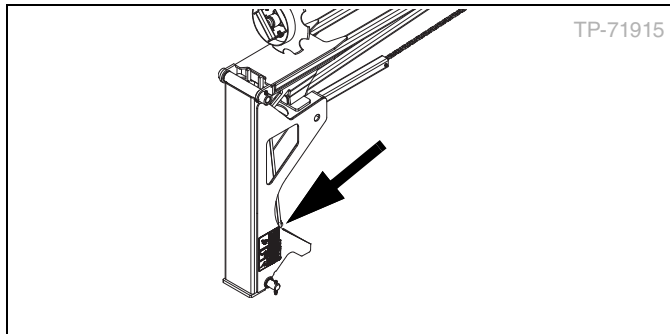

**Overhead Hazard**

818-580C



Two decals - On each marker first section; middle decal.

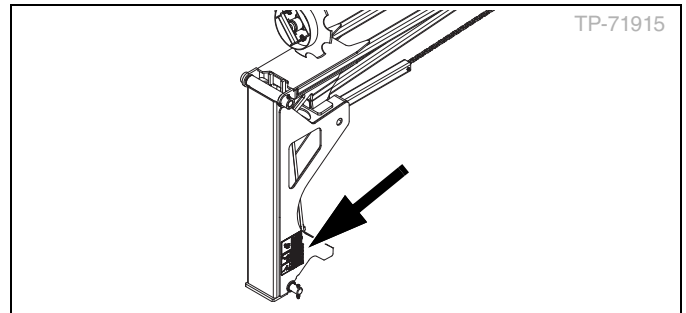

**Pinch Point Hazard**

818-579C



Two decals - On each marker first section; bottom decal.

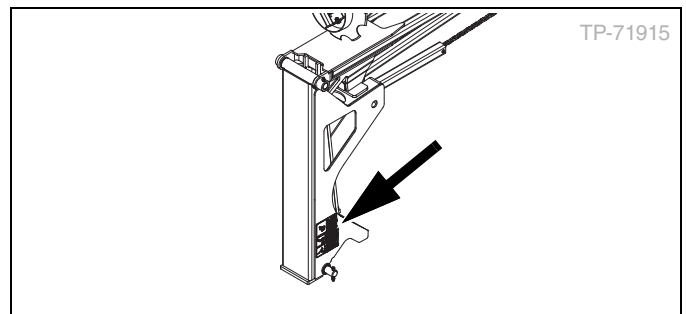

**Crushing Hazard**

818-590C



One decal - On left front of tongue.

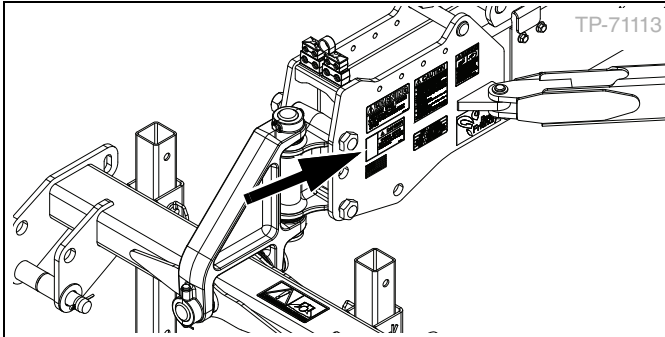

**Read Operator Manual**

848-512C



One decal - On left side of hitch.

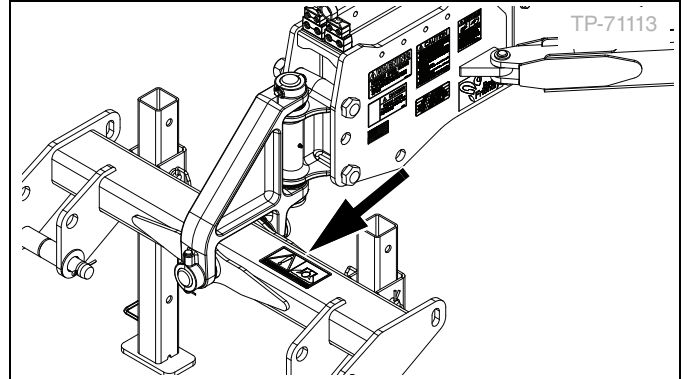

**General Information**

838-995C



One decal - On left front of tongue.

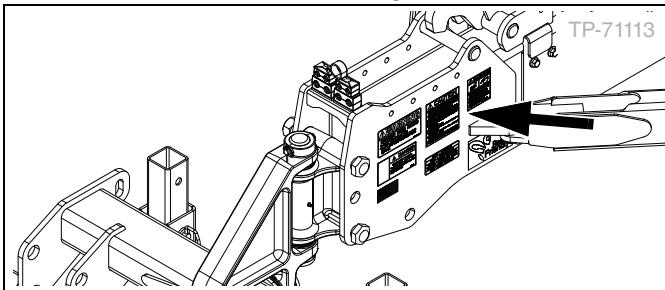

**Hot Fluid Hazard (Option)**

858-004C

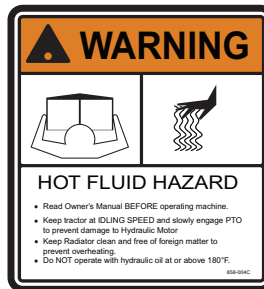

One decal - On front of PTO hydraulic reservoir.

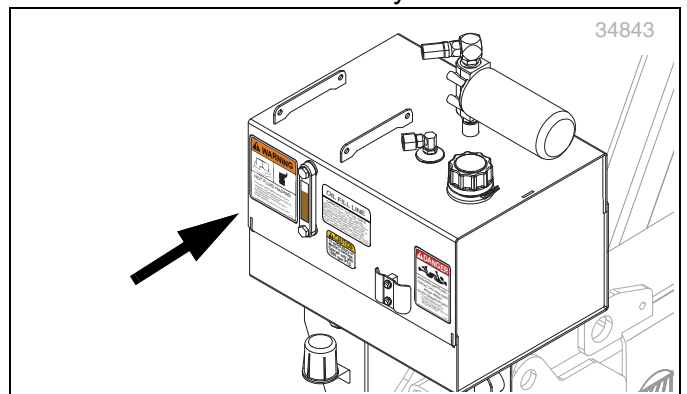

**Rotating Driveline Hazard (Option)**

858-030C



One decal - On front of PTO hydraulic reservoir.

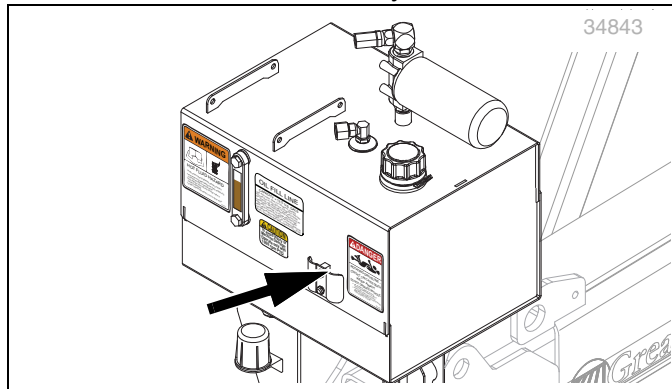

**Machine Damage (Option)**

844-496C



One decal - On side of hitch

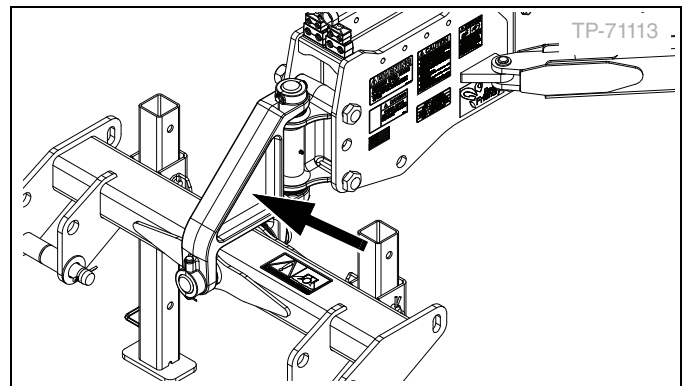

**Tire Pressure**

844-126C

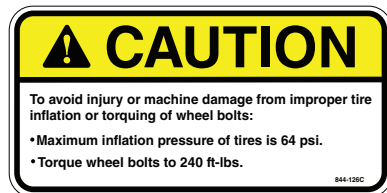

16-row planters - One decal on each wheel arm.

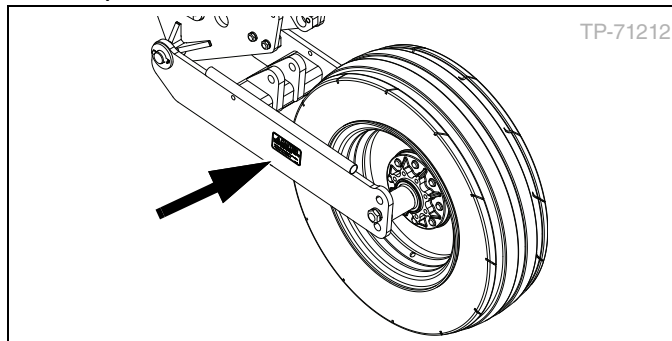

# Preparation and Setup

This section helps to prepare your tractor and planter for use. Before using the planter in the field, you must hitch the planter to a suitable tractor, inspect systems, and level.



### Flailing Hazard

Marker hydraulics are active whenever the fold hydraulics are not in use. It is important to set the tractor fold/marker hydraulic circuit lever to "Float" or "Neutral" to prevent unintended marker operations. Unexpected marker operation and flailing equipment can seriously injure including death.

## ■ Preparation Checklist

- ☑ Read and understand "Safety Information" beginning on page 2.
- ☑ Check that all working parts are moving freely, bolts are tight, and cotter pins are spread apart.
- ☑ Check that all grease fittings are in place and lubricated. See "Lubrication" on page 71.
- ☑ Check that all safety decals and reflectors are correctly placed and legible. If damaged, replace with new, legible decal or reflector. See "Safety Decals" beginning on page 5.
- ☑ Inflate tires to pressure recommended and tighten wheel bolts as specified. See "Tire Information" on page 118.
- ☑ Check the planter for worn or damaged parts. Repair or replace parts before going to the field.
- ☑ If returning the planter to use from storage, remove any grease used to protect the cylinder rods.

## ■ Hitch Planter to Tractor



### Crushing Hazard

Do not stand or place any part or your body between planter and moving tractor. Keep others away. Failure to avoid may result in severe injury or death by being crushed between tractor and planter. Stop tractor engine and set park brake before attaching harnesses or hoses.



### High Pressure Fluid Hazard

Escaping fluid under pressure can have sufficient pressure to penetrate the skin. Check all hydraulic lines and fittings before applying pressure. Use paper or cardboard, not body parts, and wear heavy gloves to check for suspected leaks. If injured, seek immediate medical attention from a physician familiar with this type of injury.

## Hydraulic Hose Connections

Great Plains hydraulic hoses have color coded handle grips to help hook up hoses to tractor outlets. Hoses that go to the same remote valve are marked with the same color.

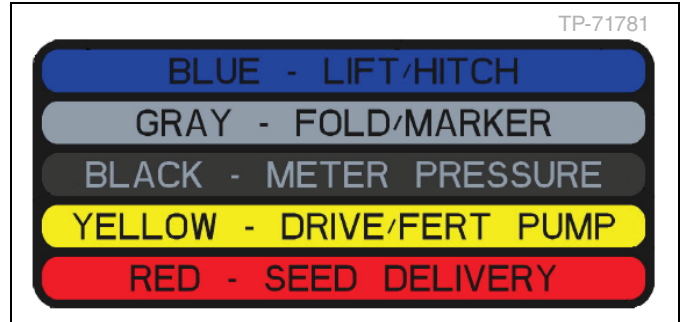

Color	Hydraulic Function
Blue	Lift/Hitch
Gray	Fold/Marker
Black	Meter Pressure
Yellow	Drive/Fertilizer Pump
Red	Seed Delivery

To distinguish hoses on the same hydraulic circuit, refer to the symbol on the handle grip. Hoses with an extended cylinder symbol (1) feed cylinder base ends. Hoses with a retracted cylinder symbol (2) feed cylinder rod ends.

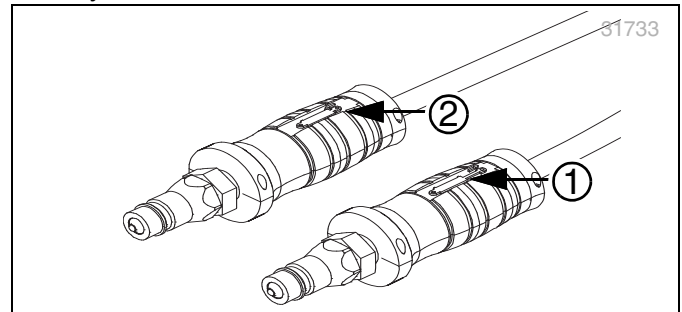

For hydraulic fan and drive motors, connect the hose with the retracted cylinder symbol to the pressure side of the motor. All motor returns combined in motor return hose.

The fan motor requires further hook up of a third line which returns hydraulic fluid from the fan motor case.

## Fan Hydraulic Connections



### Hydraulic Motor Performance Risk

Do not attach the motor return/low pressure case drain line to a power-beyond port.



**Motor Seal Damage Risk**

The case drain hose must be attached before the inlet and return hoses are connected. When disconnecting the hydraulic hoses, always detach the case drain hose last to prevent damage to the fan motor.

1. Connect the case drain hose to the low pressure drain connection.
2. Connect low pressure return hose to low pressure connector.
3. If the tractor has a limited number of remotes capable of continuous flow, use those remotes for the hydraulic fan, optional hydraulic drive, and delivery.

**Electrical Connections**

Connect the planter electrical lead to the tractor seven-pin connector. If your tractor is not equipped with an ASAE J560b seven-pin connector, contact your dealer for installation.

For ground drive planters, connect the frame fold connector. For hydraulic drive planters, connect the IBBC connector. For IRC planters, connect the IBBC and auxiliary power.

Ensure the tractor is shut down with accessory power off before making the following connections. These connections can be made in any order, and must be made before moving the planter.

- Lighting connector
- Planter console harness connector
- Speed connector (PM300 Option)
- Any optional or after-market electrical connectors

**Two-Point Hitch**



**Load Sway Hazard**

Failure to adjust 3-point arms and sway blocks can result in injury.

1. Move the tractor close to the planter hitch.
2. Raise the hitch high enough to clear the drawbar.
3. Adjust the tractor three-point arms and sway blocks to minimize side-to-side sway and assure proper tracking in the field and when transporting. See your tractor's operator manual for information.
4. Back the tractor to align the drawbar and hitch.
5. Connect the tractor to the planter two-point hitch. If using a quick hitch, be sure the planter locks into the hitch securely.



**Machine**

**Damage**

**Hazard**

Your field profile may cause machine hitch to bend at an angle that causes damage to the machine. Keep hook at no more than a 13 degree angle - bottom hole - or 25 degree angle - top hole. If unable to prevent hook from bending at a greater angle than recommended, disconnect hook..

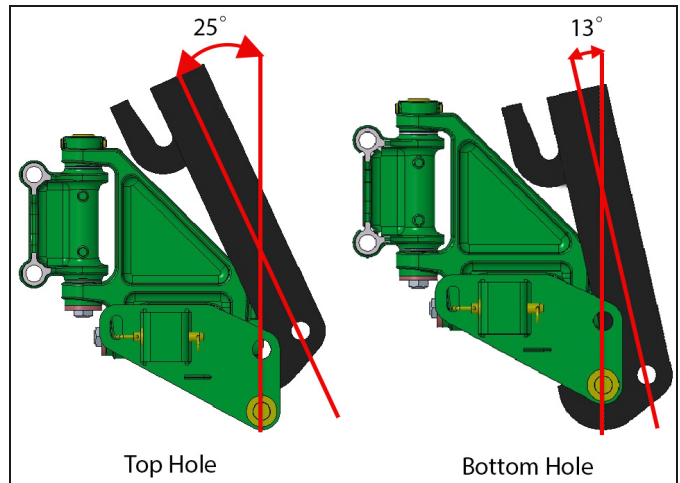

6. Raise the hitch high enough to take pressure off the parking stands.
7. Remove each pin (1) and slide up the parking stand.
8. Install the pins in the bottom hole (A) of the parking stand.

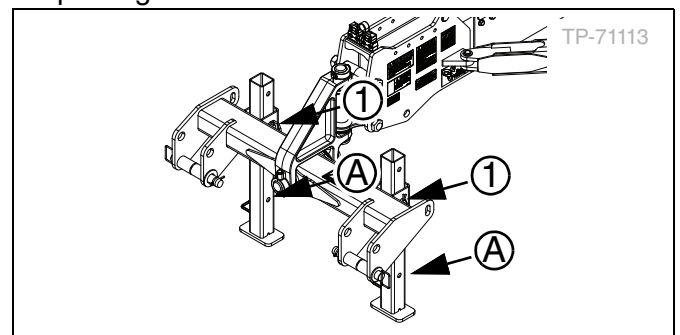

9. Connect the hydraulic hoses to the tractor remotes.
10. Make the electrical connections for the planter console or switch box.

**Weight Transfer System (Option)**



**High Pressure Fluid Hazard**

Escaping fluid under pressure can have sufficient pressure to penetrate the skin. Check all hydraulic lines and fittings before applying pressure. Use paper or cardboard, not body parts, and wear heavy gloves to check for suspected leaks. If injured, seek immediate medical attention from a physician familiar with this type of injury.



**Hydraulic Motor Performance Risk**

Do not attach the motor return/low pressure case drain line to a power-beyond port.

The weight transfer hydraulics cylinders must be free to flex during planter movements even when the system is not active.

To allow cylinder flex:

- ☑ connect the fan case drain and fan return lines to suitable receptacles, see “<Bold>Fan Hydraulic Connections”.
- ☑ inspect the hydraulic cylinders to ensure movement will not be obstructed.



Always connect the case drain hose first.

The case drain hose protects the outer seal of the hydraulic motor. It is a small line to the hitch, supplied with a specialized low-seep, flat-face case drain quick disconnect.

If your planter is configured with the optional weight transfer system, up to 1000 pounds (450 kg) of mainframe weight may be transferred to each wing when oil is being supplied to the hydraulic drive circuit. The weight transfer system uses a control valve (1) plumbed into the hydraulic drive circuit, and two hydraulic cylinders (2), one for each wing. Once set, the weight transfer system requires little adjustment for normal field operations.

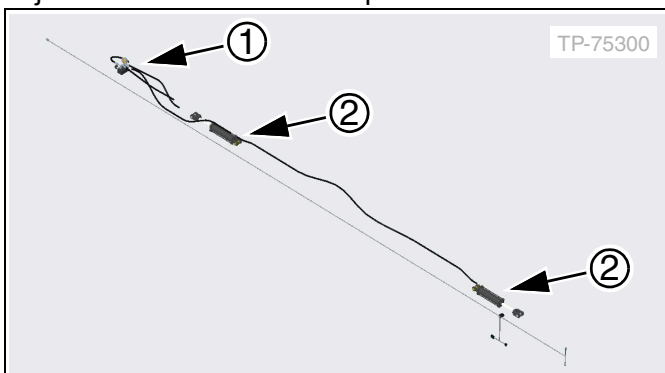

To set the valve pressure:

1. Unfold and lower the planter into field operation. See “Field Position” on page 23.

2. Supply oil to the hydraulic drive. It is not necessary to operate the hydraulic drive motor.
3. Loosen the lock disc (3) at the valve block (1). Adjust the knob (4) until the gauge (5) reads approximately 1000 psi. Tighten the lock disc (3).

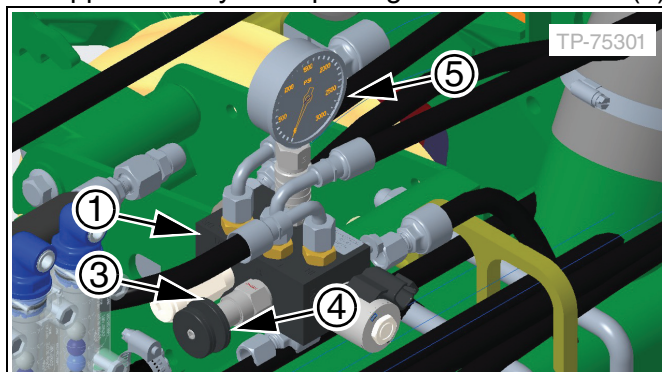

4. Lower the planter. With seeding disabled, engage the hydraulic drive. Pull forward at normal field speed for a short distance. Stop.
5. Verify the wings are level.

If not:

- decrease the pressure at the valve (5), if the wings are lower than the center frame.
- increase the pressure at the valve (5), if the wings are higher than the center frame.

It may be necessary to level the planter frame if adjusting the weight transfer hydraulic pressure.

**Rephasing Hydraulics**



**High Pressure Fluid Hazard**

Do not attempt to make hydraulic system repairs. Great Plains strongly recommends that all hydraulic system repairs to be completed by a trained professional who is knowledgeable about how to safely complete hydraulic system work. You should only maintain or adjust your hydraulic system as described within this manual. Compromising a closed hydraulic system can cause serious injury or death.



**Planter Damage Risk**

Do not fold or unfold without first fully raising planter completely or damage will occur.

The hydraulic system is fully charged and bled at the factory prior to shipping. The fold and lift hydraulic systems have been equipped with rephasing cylinders. Rephasing hydraulic cylinders are designed to purge small amounts of air from the system. It is necessary to rephase cylinders by extending lever for 5-10 seconds after the cylinders have been fully extended. Rephasing cylinders will

allow for any air present in the system to be released through a rephase port on the cylinder. Ensure the tractor's hydraulic oil reservoir is full. Refer to your tractor's operator manual for more information.

If the several attempts to rephase cylinders fail to produce smooth hydraulic motions, it may be a sign that your hydraulic system may need to be serviced by a trained professional; contact your Great Plains dealer for service.

■ **Planter Leveling**

All frame sections must be level to maintain even planting depth. Before using the planter in the field, verify the planter is level side-to-side.

Periodic frame leveling adjustments should not be necessary, but if there are problems with uneven depth, check the planter levelness and follow these procedures.

Before making any adjustments, ensure lift cylinders are rephased and operating properly. See "Rephasing Hydraulics" on page 15.

1. Unfold the planter fully. See "Unfolding" on page 23.
2. Put the planter in field position. See "Field Position" on page 23.
3. Set the hitch so the top of the tongue tube is 36.5 in (93 cm) above the ground (A). This is the starting point for adjustments.

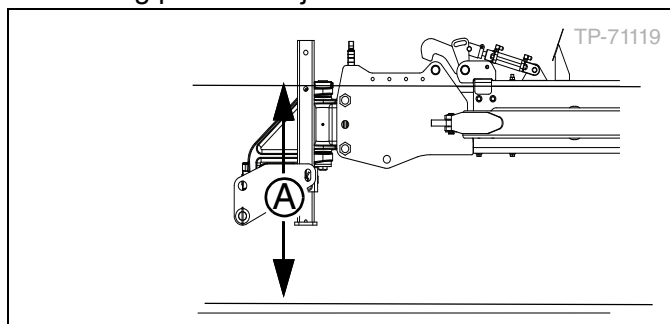

4. Adjust the hitch until the bottom of the frame tube at the end of each wing measures approximately 26 inch (66 cm) from the ground (B).

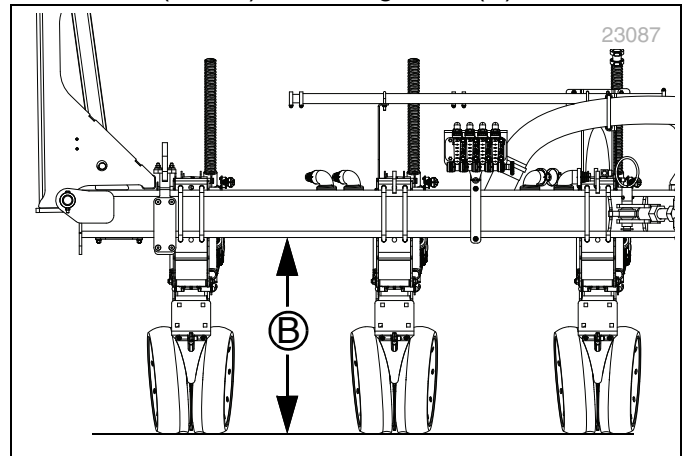

■ **Speed Calibration**

Calibrate the speed sensor the first time the planter is operated in the field - with or without planting. See the console manual for this procedure.

Cross-check the console speed reading with the tractor speedometer.

■ **Speed Sensor**

The console uses the pickup wheel for measuring planter ground speed. The speed sensor should be set 1/16 to 1/8 inch (1.6 to 3.2 mm) from the pickup wheel.

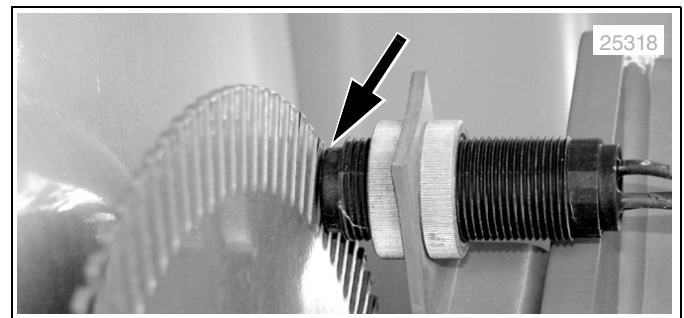

There are two sensors on planters, one on each wing. On planters configured with 12 rows, the two sensors are on the single wing gauge on each wing. On

planters configured with 16 rows, the two sensors are located on the outside wing gauge wheels.

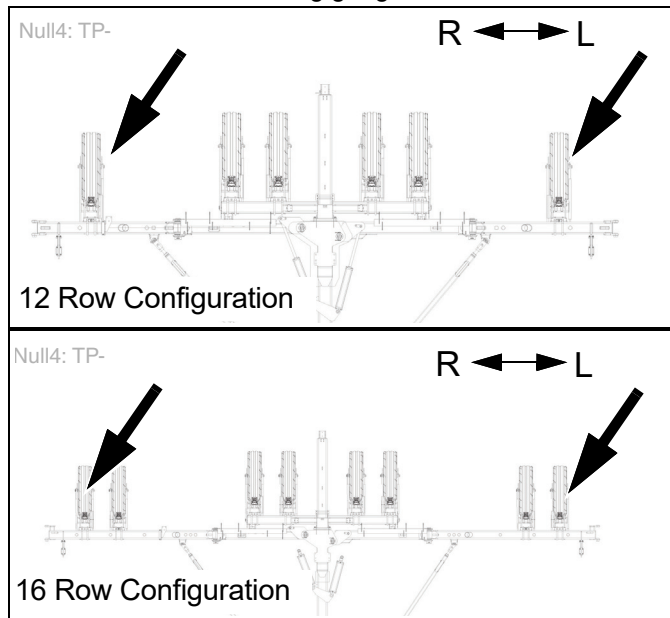

■ **Markers**



**Electrocution Hazard**

*Machine is not grounded. To prevent serious injury or death, keep clear of overhead power lines when transporting, folding, unfolding, or operating all planter components. At higher voltages, electrocution can occur without direct contact.*



**Flailing Hazard**

*Marker hydraulics are active whenever the fold hydraulics are not in use. It is important to set the tractor fold/marker hydraulic circuit lever to "Float" or "Neutral" to prevent unintended marker operations. Unexpected marker operation and flailing equipment can seriously injure including death.*



**Pinch, Crush, and Sharp Object Hazards**

*Markers can fall quickly and unexpectedly if the hydraulics fail. Serious injury can result if caught or struck by a moving marker. Never allow anyone near the planter when folding or unfolding the markers.*



**Sharp Objects Hazard**

*Marker disks may be sharp. To avoid serious injury, wear gloves when working in this area.*

Markers have three adjustments:

- Extension length
- Chain length
- Disk angle

**Marker Extension Length**

Marker extension (A) is the distance from the mark in the ground to the centerline (or furrow) of the end row unit.

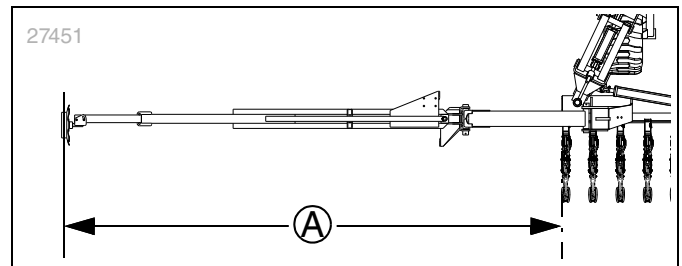

**To measure for marker width adjustment:**

1. Lower the planter in the field and move forward a few feet.
2. Measure from the centerline of the outside active row to the mark in the ground made by the marker disk.

When correctly adjusted, there is a gap of one row space between passes as measured between centerlines of outside rows.

The table below provides suggested initial values.

Model	1230	1630	1270	1670
Row Spacing	30 inch	30 inch	--	--
	76.2 cm	76.2 cm	70 cm	70 cm
Span	330 inch	450 inch	--	--
	838 cm	1143 cm	770 cm	1050 cm
Swath	360 inch	480 inch	--	--
	914 cm	1219 cm	840 cm	1120 cm

When operating with rows locked up, measure to the outside row whether in use or not. Extension values may be different for the left-hand and right-hand sides, each pass in the opposite direction, and each pass in the same direction.

**To adjust marker extension:**

1. Loosen the nuts (1) on the u-bolts (2).

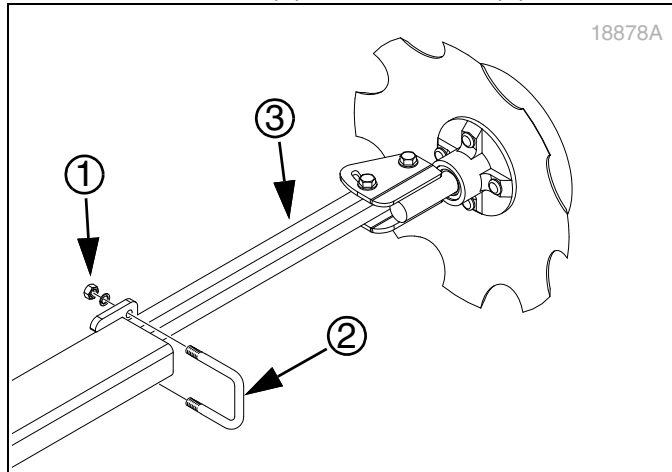

2. Move the marker disk tube (3) in or out to get the proper adjustment.

**Marker Chain Length**



**Planter Damage Risk**

Keep the marker chain slack within one inch (2.4 cm) of 18 inches (46 cm). A chain length too short or too long can result in marker or planter damage.

Correct chain slack will need to be set before first use. Correct slack needs to be maintained with periodic checks.

Set the initial chain length, perform chain slack checks, and make adjustments with the marker folded.

**To check marker chain slack:**

1. At the mid-point in the exposed chain, pull it towards the front of the planter.
2. Measure the distance between the mid-point and the nearest point on either of the two parallel tubes of the marker arm. The target value is 18 inches (46 cm).

**To adjust the length:**

1. Remove the bolt and nut at the lower end of the chain.
2. Adjust the chain length within 18 inches (46 cm) of chain slack.

**Marker Disk Angle**

Adjusting the angle of the marker will increase or decrease the width of the mark the marker disk leaves in the dirt.

**To change the angle of cut and the width of the mark:**

1. Loosen the 1/2 inch bolts (1) holding the disk assembly.

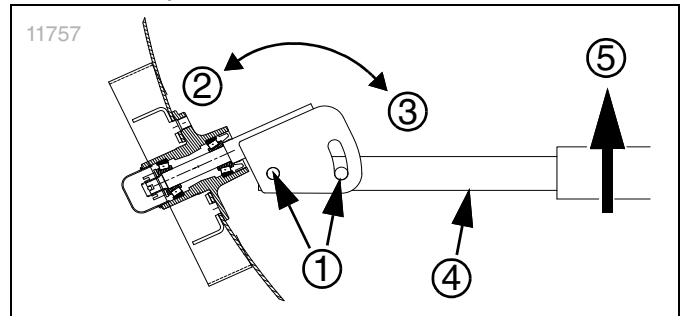

2. For a wider mark, increase the angle (2) of the marker disk with respect to the tube (4). For a narrower mark reduce the angle (3).
3. Tighten the bolts.

The direction of travel (5) tends to drive the disk angle wider. If the bolts are not tight enough, or loosen over time, the disk will slip into the wide configuration.

**■ Bulk Hopper Level Sensors (Option)**

If your planter is configured with bulk hoppers there are factory-installed hopper level sensors inside the bulk hoppers. Hopper level data will be display on the IntelliAg ISO6 capable in-cab console.

**■ Rear Auxiliary Hydraulics (Option)**

If the planter is equipped with an auxiliary hydraulic drive system, set the selector valve (1), near the sequence valve (2), at the marker base on the left wing to “Marker”.

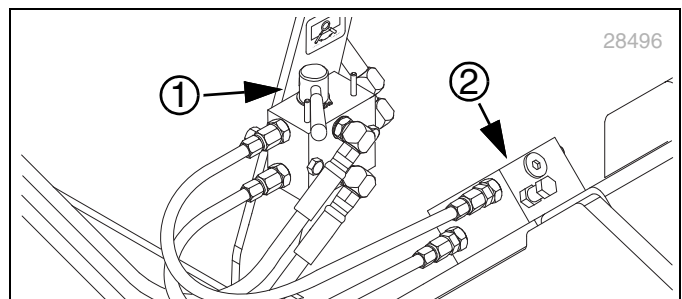

**■ Liquid Fertilizer Pump (Option)**

If your planter is configured with the optional liquid fertilizer system, initial pump start up instructions are found in the included piston pump operator manual and will need to be completed before initial use.

Refer to your John Blue piston pump operator manual.

## Operation

This section covers general operating procedures and adjustments necessary for the best field performance and results. Experience, machine familiarity, and the following information will lead to efficient operation and good working habits. Always operate farm machinery with safety in mind.

Even if planting conditions rarely change, some items need periodic adjustment due to normal wear.

### ■ Pre-Start Checklist

- ☑ Read and understand “**Safety Information**” beginning on page 2.
- ☑ Check that all working parts are moving freely, bolts are tight, and cotter pins are spread apart.
- ☑ Check that all grease fittings are in place and lubricated. See “**Lubrication**” on page 71.
- ☑ Check that all safety decals and reflectors are correctly placed and legible. If damaged, replace with new, legible decal or reflector. See “**Safety Decals**” beginning on page 5.
- ☑ Inflate tires to pressure recommended and tighten wheel bolts as specified. See “**Tire Information**” on page 118.
- ☑ Check the planter for worn or damaged parts. Repair or replace parts before going to the field.
- ☑ If returning the planter to use from storage, remove any grease used to protect the cylinder rods.

### ■ Field Operation



#### **Electrocution Hazard**

*Keep clear of overhead power lines when unfolding, folding, operating, or transporting the planter. The machine is not grounded. At higher voltages, electrocution can occur without direct contact. Any line voltage present on planter or tractor can cause severe injury or death.*



#### **Flailing Hazard**

*Marker hydraulics are active whenever the fold hydraulics are not in use. It is important to set the tractor fold/marker hydraulic circuit lever to “Float” or “Neutral” to prevent unintended marker operations. Unexpected marker operation and flailing equipment can serious injures including death.*

### Before Planting Checklist

- ☑ Check electrical and hydraulic connections.
- ☑ Verify planter is leveled (page 15).
- ☑ Verify marker extension and marker disk angle are set correctly (page 16).

- ☑ Set up the seed meters for correct seed (page 45).
- ☑ Set planting rate. See the Material Rate manual.
- ☑ Set fertilizer rate, if required. See the Material Rate manual.
- ☑ Review the console for any diagnostic messages.
- ☑ Check chain tension (page 68).
- ☑ Verify meter inlet gates are open to chart value. See Material Rate manual.
- ☑ Verify hoses are fully connected to meters.
- ☑ Close and latch all hopper lids.
- ☑ Set planting depth handles at the same setting (page 54).
- ☑ Set down pressure springs at the same setting except in tracks (page 52).
- ☑ Check coulter alignment to the row (page 59).
- ☑ Set press wheels in the same position except in tracks (page 56).
- ☑ Check fan operation (page 39).

### Begin Planting

- Unfold and line up the planter at the start of the first row.
- Prime the meters with seed (page 47). Leave the fan running.
- Unfold the marker on the next-row side.
- Pull forward, lower the planter, and begin planting for a short distance.
- Stop and check the planting depth, seed spacing, press wheel operation, and fertilizer application, if in use.
- Make the necessary adjustments and resume planting.
- Turns:
  - Fold the marker, raise the planter, and make the turn.
  - Lower the planter, unfold the marker on the next-row side, and resume planting.

### End Planting

- Stop the tractor.
- Set the fan hydraulic circuit(s) to “Float” or “Neutral”.
- Fold the marker.
- Raise the planter and install transport cylinder locks (page 18).
- Fold the wings (page 26) and engage wing hooks (page 19).
- Turn on lights for transport.

### ■ Transport Locks

### Wing Hooks

Wing hooks prevent the planter from unfolding while the wing hooks are resting on the tongue stop (shown).

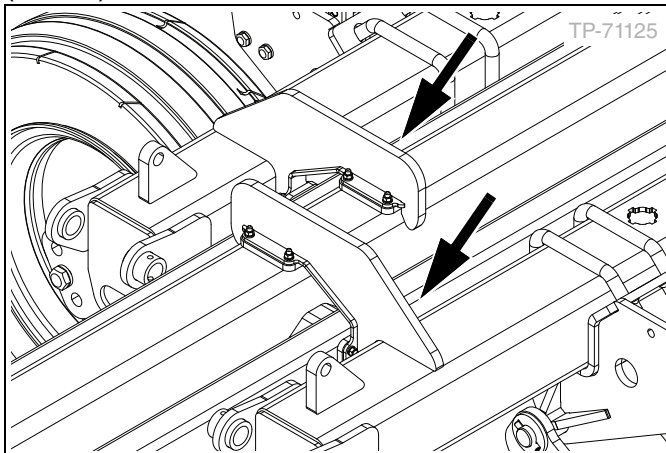

To release wing hooks with two-point hitch:

1. Use the tractor lift lever to fully raise the planter.
2. Lower the two-point hitch.
3. Verify the wing hooks have been released by raising above the tongue stop.
4. Set tractor lift hydraulic lever to "Neutral".

### Cylinder Locks

A cylinder lock installed on each lift cylinder prevents the frame from lowering during transport and maintenance. For transport and maintenance, a cylinder lock must be used on each lift cylinder on the main transport tires. The cylinder lock is easily identifiable by its red coloring.

To install cylinder lock:

1. Use the tractor lift lever to fully raise the planter.
2. Set tractor lift hydraulic circuit to "Neutral".
3. Remove the cylinder lock (1) from storage position (shown).

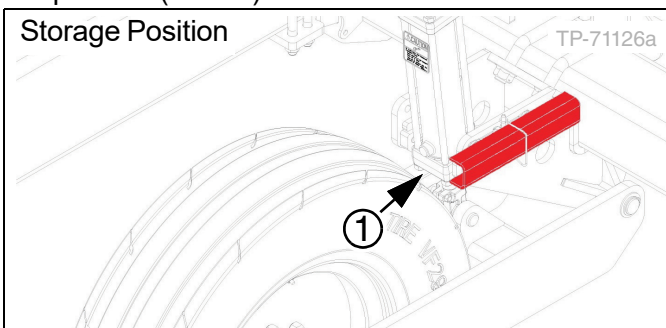

4. Place the cylinder lock (1) on the fully raised lift cylinder rod and secure with pin (2).

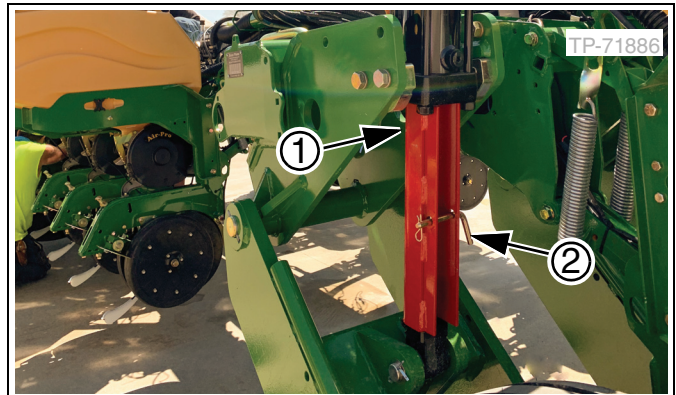

5. Repeat for each of the four lift hydraulic cylinders on the main transport tires.

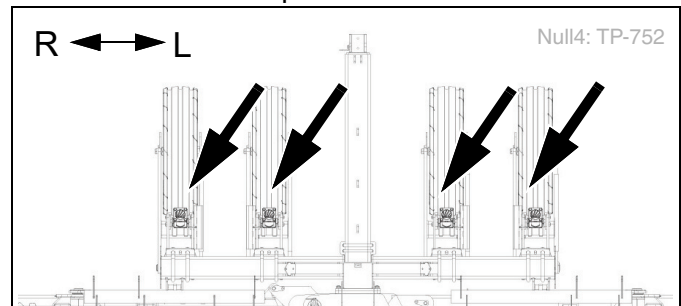

To remove cylinder lock:

1. Use the tractor lift lever to fully raise the planter.
  -  The planter may have settled onto the cylinder locks while installed. It will be necessary to raise the planter in order to remove the cylinder locks.
2. Set tractor lift hydraulic circuit to "Neutral".
3. Pull pin (2) and release cylinder lock (1) from the cylinder rod.

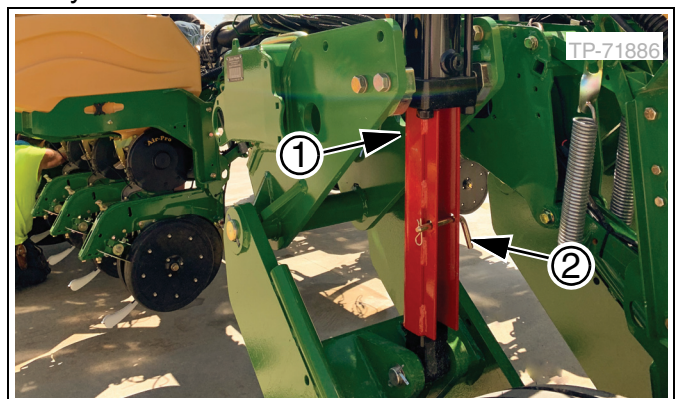

4. Stow cylinder lock in the storage location.

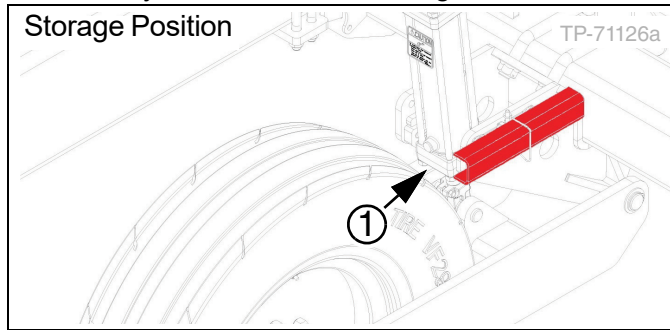

5. Repeat for each of the four lift hydraulic cylinder rods on the main transport tires.

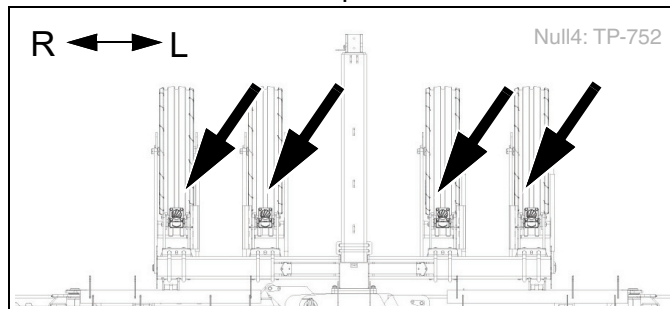

**Tongue Hook Latch**

**Machine Damage Risk**  
 Frame and opener damage is likely if the planter is operated when tongue hook latch is not secured. The tongue hook automatically latches only when the planter is fully unfolded.

The tongue hook latch operates automatically during the folding/unfolding. The tongue hook latch will automatically lock when the planter is fully unfolded. It will release as the planter begins to fold.

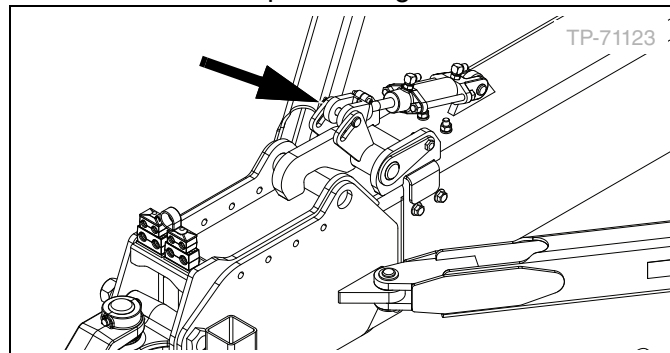

**Operation Controls**

Your PL5700 Planter may be configured with a combination of devices and consoles for operational control of your planter depending on the overall configuration of planter options and accessories.

**IntelliAg ISO6**

If your planter is configured with hydraulic or electric drive, your planter will be configured with IntelliAg ISO6 on a console. The planter may also be operated with a customer-provisioned WSMT compatible console.

**PL5700 Switch Box**

The PL5700 switch box allows for in-cab use of hydraulic systems and an optional electric clutch control on planters configured with ground drive.



**Raising/Lowering Tongue**



**Crushing Hazard**

Do not stand or place any part or your body between planter and tractor without first removing the tractor key and setting the parking brake before making adjustments in the hitch area or surrounding area between the tractor and planter. Keep others away. Failure to follow instructions may result in severe injury or death by being crushed between tractor and planter.

The PL5700 Planter tongue raises and lowers independently of the planter frame. The two-point hitch will be manually adjusted to raise and lower the tongue.

**Raising/Lowering Wing Gauge Wheels**



**Crushing Hazard**

Keep all persons away from openers and wings during lowering and raising. Openers and wings will cut or crush anything beneath them, and can result in serious injury or death.

The PL5700 Planter is designed to raise/lower the wing gauge wheels for the fold and unfolding operations.

**With IntelliAg ISO6**

1. With your in-cab console, tap the Fold Sequence softkey from the Home screen.

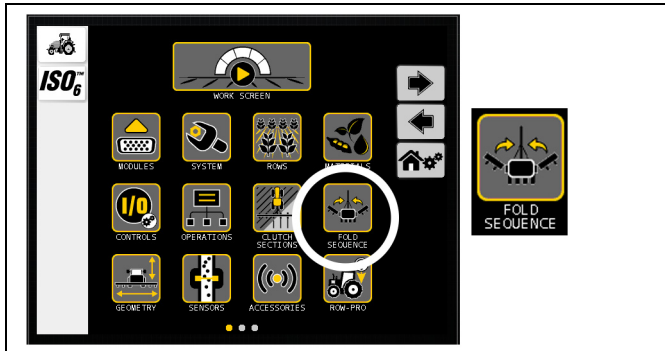

2. Tap the Wing Lift softkey to set the Wing Lift hydraulic system to active. This is indicated by the Wing Lift softkey changing to a blue Active Wing Lift softkey.

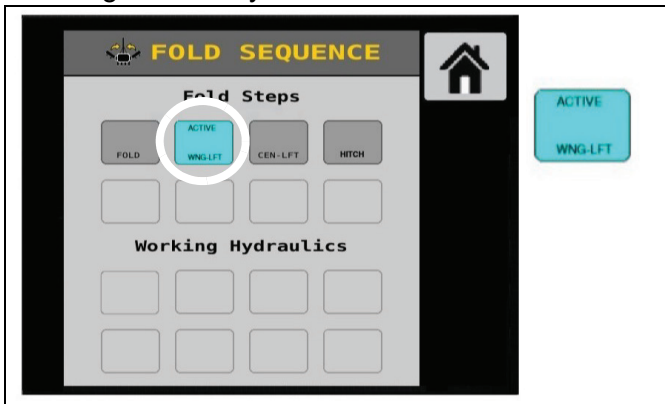

3. Use the tractor lift circuit to raise/lower the wing gauge wheels.
4. When the wheel gauge wheels are at the desired height, set the lift hydraulic circuit to "Neutral".
5. Tap the Active Wing Lift softkey so wing lift hydraulic system is no longer active.

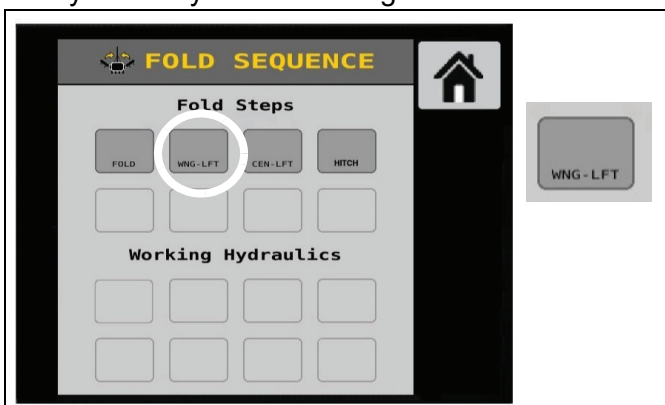

**With Switch Box**

1. On the switch box, toggle the on/off power switch to ON.



2. On the switch box, toggle the marker/fold switch to MARKER.



3. On the switch box, toggle the lift switch to WING.



4. Use the tractor lift circuit to raise/lower the wing gauge wheels.
5. When the wheel gauge wheels are at the desired height, set the lift hydraulic circuit to "Neutral".

**■ Raising the Planter**

**⚠ Crushing Hazard**  
 Keep all persons away from openers and wings during lowering and raising. Openers and wings will cut or crush anything beneath them, and can result in serious injury or death.

**⚠ Falling Hazard**  
 Do not stand on tires. Wheels may have little or no weight on them, and may turn suddenly and without warning if used as a step, resulting in serious injury.

The planter mainframe raises and lowers independently of the tongue. These instructions will raise the planter frame and the wing gauge wheels.

**With IntelliAg ISO6**

1. Use tractor lift hydraulic lever to raise the planter.
2. Set tractor lift hydraulic circuit to “Neutral”.
3. Install cylinder locks if raising for transport, parking, storage, adjustments, or maintenance. The planter must be fully raised for installation. See “Cylinder Locks” on page 19.



The planter must be fully raised for installation. See “Cylinder Locks” on page 19.



**With Switch Box**

1. On the switch box, toggle the marker/fold switch to *MARKER*.



2. On the switch box, toggle the lift switch to the center position *WHEELS*.



3. Use tractor lift circuit lever to raise the planter.
4. Set the lift tractor circuit to “Neutral”.
5. Install cylinder locks if raising for transport, parking, storage, adjustments, or maintenance.

**Lowering the Planter**



**Crushing Hazard**

Keep all persons away from openers and wings during lowering and raising. Openers and wings will cut or crush anything beneath them, and can result in serious injury or death.



**Falling Hazard**

Do not stand on tires. Wheels may have little or no weight on them, and may turn suddenly and without warning if used as a step, resulting in serious injury.



**Planter Damage Risk**

The planter should not be in a lowered position during a field turn or planter damage will occur.

The planter mainframe raises and lowers independently of the tongue.

**With IntelliAg ISO6**

1. If installed, remove cylinder locks and stow in storage position.
2. Use tractor lift hydraulic lever to lower the planter.
3. Set tractor lift hydraulic circuit to “Neutral”.

**With Switch Box**

1. If installed, remove cylinder locks and stow in storage position.
2. On the switch box, toggle the on/off power switch to ON.



3. On the switch box, toggle the marker/fold switch to **MARKER**.



4. On the switch box, toggle the lift switch to the center position **WHEELS**.



5. Use tractor lift circuit lever to lower the planter.
6. Set the lift tractor circuit level to “Neutral”.

**Field Position**

You will achieve field position by lowering the planter into the field and pulling forward a few feet.

**Unfolding**



**Pinch Point and Crushing Hazards**

Moving parts can pinch or crush causing serious injury or death. Distance between tractor and planter will decrease when unfolding and increase when folding. Keep all persons away when folding or unfolding the planter.



**Flailing Hazard**

Marker hydraulics are active whenever the fold hydraulics are not in use. It is important to set the tractor fold/marker hydraulic circuit lever to “Float” or “Neutral” to prevent unintended marker operations. Unexpected marker operation and flailing equipment can seriously injure including death.



**Tire Damage Risk**

Verify the tractor gear is in “Neutral” before folding or unfolding to avoid damage to tires.



**Planter Damage Risk**

Do not fold or unfold without first fully raising planter completely or damage will occur.

The distance between the tractor and planter frame will decrease by about 10 ft (3 m) during unfolding. The planter and/or tractor will move during this operation.

The two-point hitch is raised and lower during the operation to adjust the tongue height.

If the planter is equipped with a rear auxiliary hydraulic drive system, set the selector valve (1), near the sequence valve (2), near the wing hinge on the left wing to “Marker”. This selection must be made even when the planter is not configured with optional markers or the fold hydraulics will not be able to be activated.

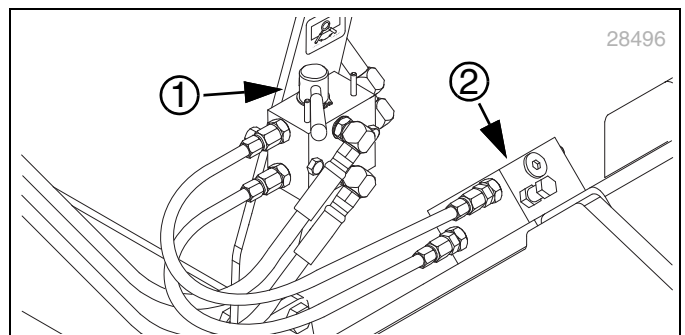

**With IntelliAg ISO6**

1. Move the planter to level ground with adequate overhead and side-to-side clearances for the unfold operation.

- If installed, remove cylinder locks and stow in storage position (page 19).

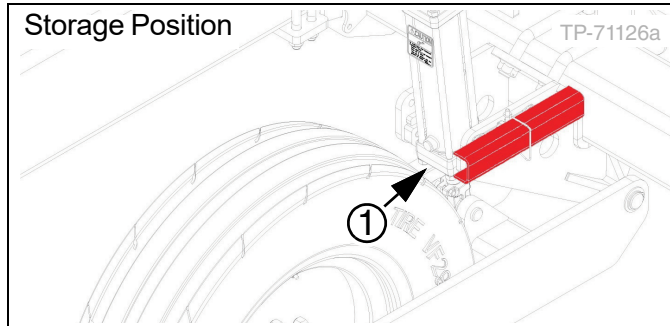

- If installed, ensure markers are fully folded (page 29).
- As equipped, set tractor circuit levers for the fan(s) and hydraulic drive to “Neutral”.
- Put the tractor gear in “Neutral”.
- Use tractor lift circuit to fully raise the planter.
- Fully lower the two-point hitch.
- Confirm the wing hooks have been disengaged from the tongue stop.
- With your in-cab console, tap the Fold Sequence softkey from the Home screen.

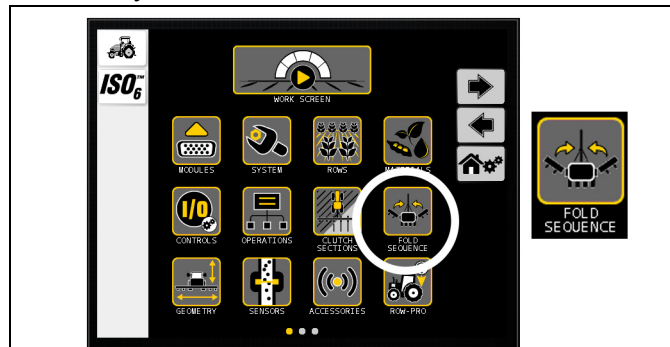

- Tap the Fold softkey to set the fold hydraulic system to active. This is indicated by the Fold softkey changing to a blue Active Fold softkey.

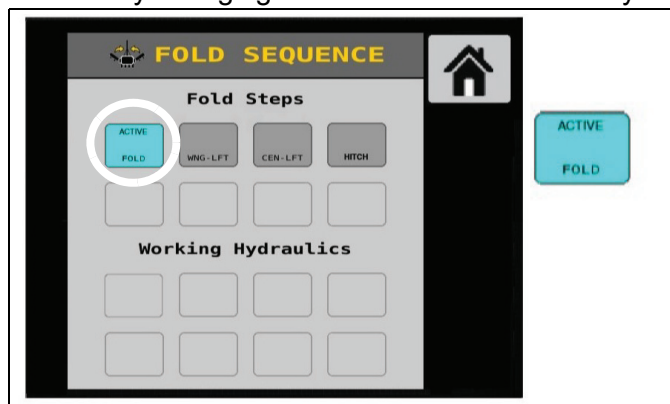

For partial unfolding, either tap the Stop softkey (not shown) or set lever to “Neutral” while the planter is unfolding.

- Use the tractor fold circuit lever until the planter is fully unfolded and the tongue hook (1) is latched.

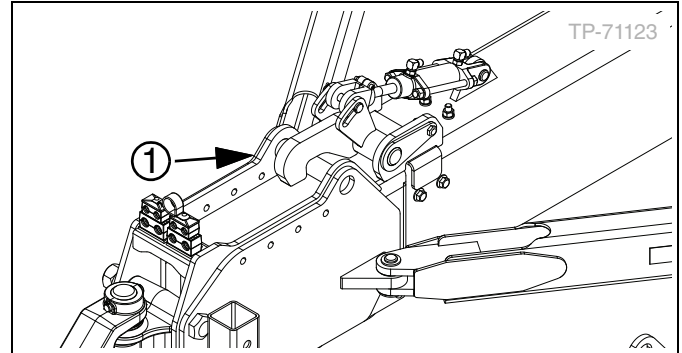

The hydraulic cylinder on the tongue hook latch will operate automatically during the fold/unfold procedure.

- When unfolding is complete, tap the Active Fold softkey so fold hydraulic system is no longer active.

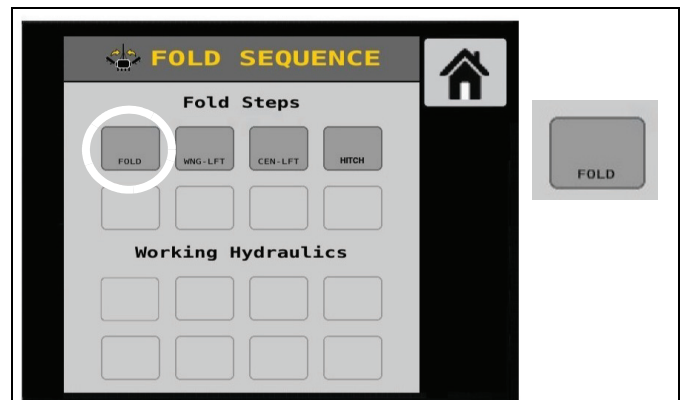

**With Switch Box**

- Move the planter to level ground with adequate overhead and side-to-side clearances for the unfold operation.

2. If installed, remove cylinder locks and stow in storage position (page 19).

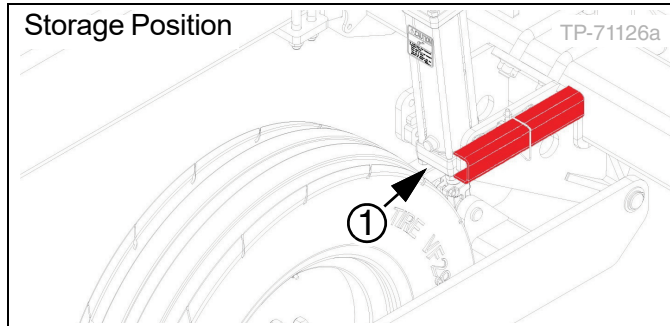

3. If installed, ensure markers are fully folded (page 29).

4. As equipped, set tractor circuit levers for the fan(s) and hydraulic drive to “Neutral”.

5. Put the tractor gear in “Neutral”.

6. On the switch box, toggle the on/off power switch to ON.



7. On the switch box, toggle the marker/fold switch to *MARKER*.



8. On the switch box, toggle the lift switch to the center position *WHEELS*.



9. Use tractor lift circuit lever to fully raise the planter.

10. Fully lower the two-point hitch.

11. Confirm the wing hooks have been disengaged from the tongue stop.

12. Set the lift hydraulic circuit to “Neutral”.

13. On the switch box, toggle the marker/fold switch to *FOLD*.



14. Use the tractor fold circuit lever until the planter is fully unfolded and the tongue hook (1) is latched.

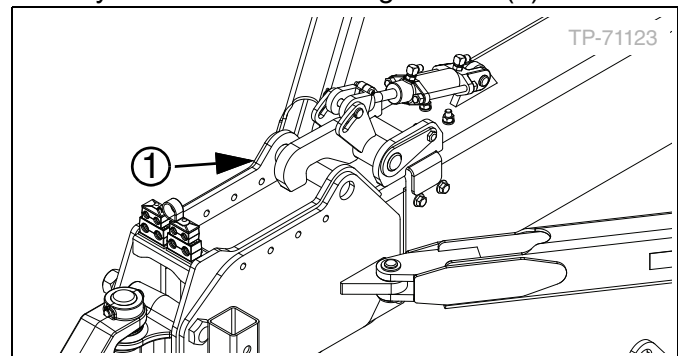

The hydraulic cylinder on the tongue hook latch will operate automatically during the fold/unfold procedure.

15. Set the fold hydraulic circuit to “Neutral”.

16. On the switch box, toggle the marker/fold switch to *MARKER*.



■ **Folding**



**Pinch Point and Crushing Hazards**

Moving parts can pinch or crush causing serious injury or death. Distance between tractor and planter will decrease when unfolding and increase when folding. Keep all persons away when folding or unfolding the planter.



**Flailing Hazard**

Marker hydraulics are active whenever the fold hydraulics are not in use. It is important to set the tractor fold/marker hydraulic circuit lever to “Float” or “Neutral” to prevent unintended marker operations. Unexpected marker operation and flailing equipment can seriously injure including death.



**Tire Damage Risk**

Verify the tractor gear is in “Neutral” before folding or unfolding to avoid damage to tires.



**Planter Damage Risk**

Do not fold or unfold without first fully raising planter completely or damage will occur.

Fold the planter for moves between fields, transport over public roads, parking, and storage.

The two-point hitch is raised and lower during the operation to adjust the tongue height.

If the planter is equipped with a rear auxiliary hydraulic drive system, set the selector valve (1), near the sequence valve (2), near the wing hinge on the left wing to “Marker”. This selection must be made even when the planter is not configured with optional markers or the fold hydraulics will not be able to be activated.

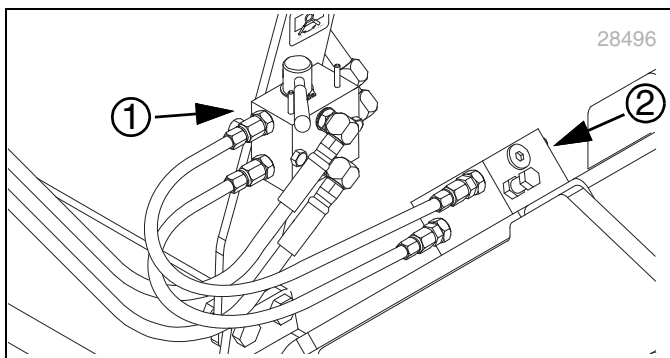

**With IntelliAg ISO6**

1. Move the planter to level ground with adequate overhead and side-to-side clearances for the fold operation.
2. If installed, ensure markers are fully folded (page 29).

3. As equipped, set tractor hydraulic circuit levers for the fan(s) and hydraulic drive to “Neutral”
4. Use tractor lift hydraulic circuit lever to fully raise the planter.
5. Set tractor lift hydraulic circuit lever to “Neutral”.
6. Lower the two-point hitch.
7. Set the tractor gear to “Neutral”.
8. With your in-cab console, tap the Fold Sequence softkey from the Home screen.

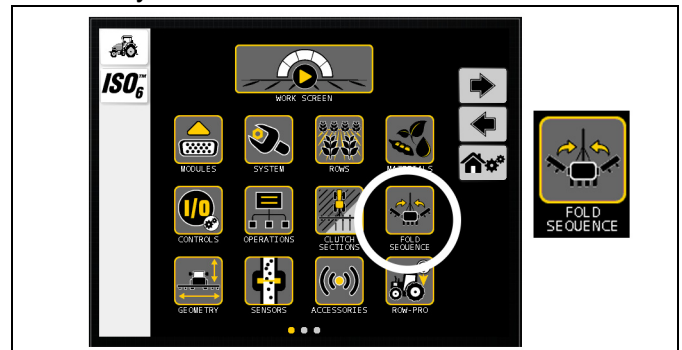

9. Tap the Fold softkey to set the Fold hydraulic system to active. This is indicated by the Fold softkey changing to a blue Active Fold softkey.

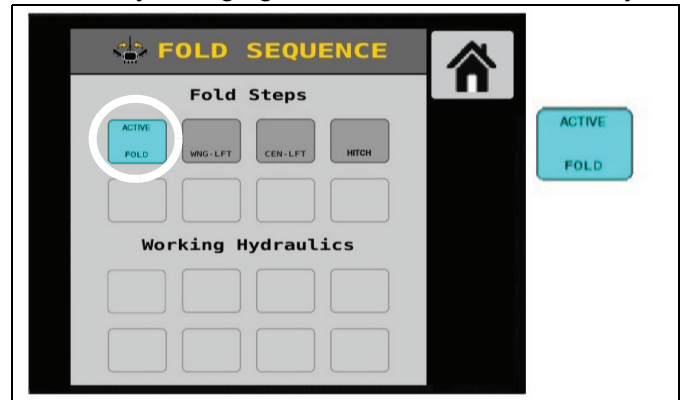

For partial unfolding, either tap the Stop softkey (not shown) or set lever to “Neutral” while the planter is unfolding.

10. Use tractor fold hydraulic circuit lever until the planter is fully folded.
11. Set the fold hydraulic circuit lever to “Neutral”.

12. When folding is complete, tap the Active Fold softkey so fold hydraulic system is no longer active.

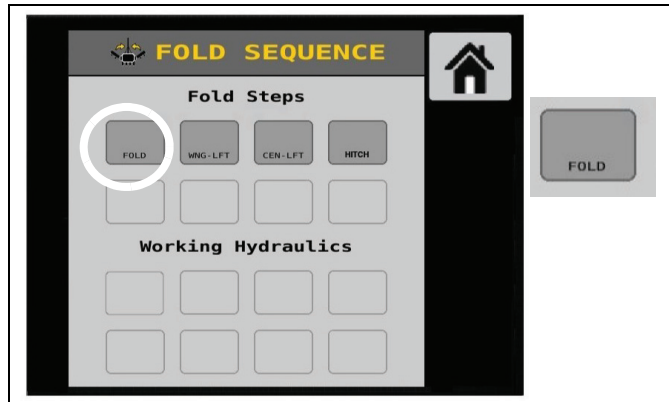

13. Raise the two-point hitch.

14. Verify the wing hooks are resting on tongue stop.

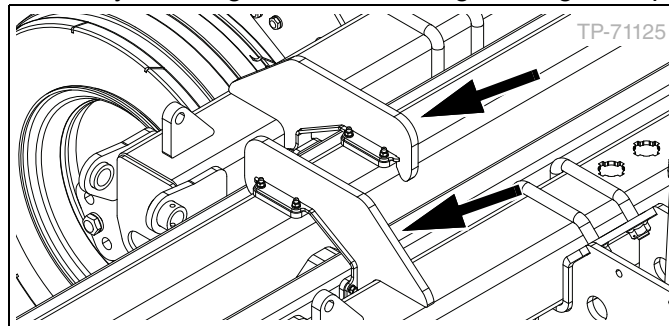

15. Install cylinder locks on the four lift hydraulic cylinder rods on the center frame if folding

planter for transport, parking, storage, adjustments, or maintenance.

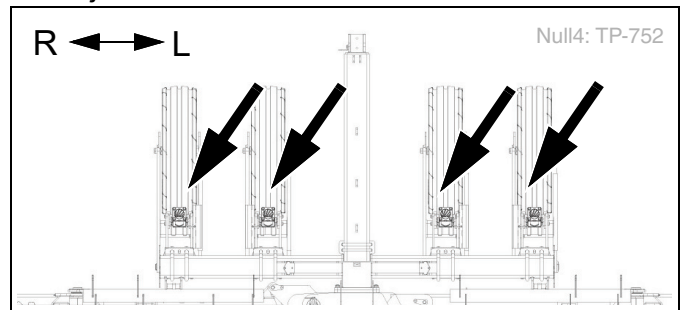

**With Switch Box**

1. Move the planter to level ground with adequate overhead and side-to-side clearances for the fold operation.
2. If installed, ensure markers are fully folded (page 29).
3. As equipped, set tractor hydraulic circuit levers for the fan(s) and hydraulic drive to "Neutral".
4. Set the tractor gear to "Neutral".
5. On the switch box, toggle the on/off power switch to ON.



- On the switch box, toggle the marker/fold switch to **FOLD**.



- Use tractor lift hydraulic circuit lever to fully raise the planter.
- Set the tractor lift hydraulic circuit lever to "Neutral".
- Fully lower the two-point hitch.
- Use the tractor fold circuit lever to fold the planter.
- Set tractor fold hydraulic circuit lever to "Neutral".
- Raise the two-point hitch.
- Verify the wing hooks are resting on tongue stop.

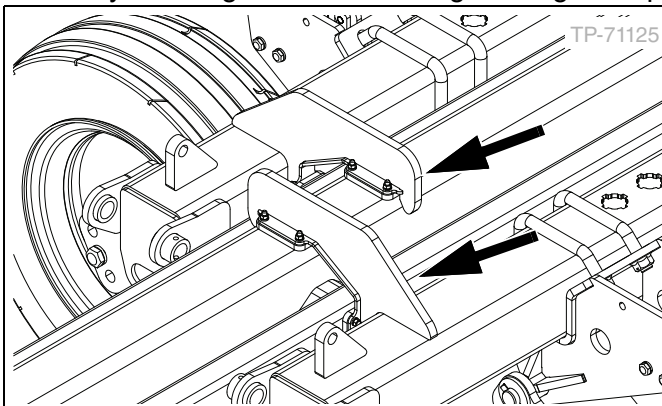

- Install cylinder locks on the four lift hydraulic cylinder rods on the center frame if folding

planter for transport, parking, storage, adjustments, or maintenance.

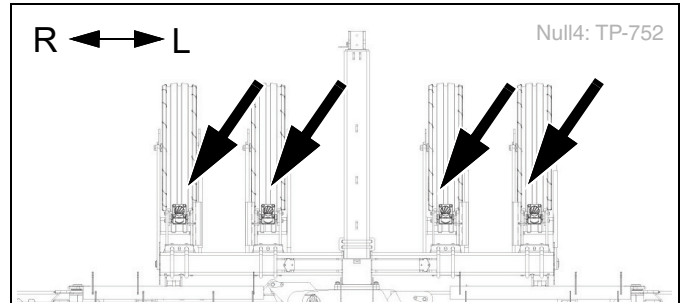

■ **Markers (Option)**



**Electrocution Hazard**

*Machine is not grounded. To prevent serious injury or death, keep clear of overhead power lines when transporting, folding, unfolding, or operating all planter components. At higher voltages, electrocution can occur without direct contact.*



**Flailing Hazard**

*Marker hydraulics are active whenever the fold hydraulics are not in use. It is important to set the tractor fold/marker hydraulic circuit lever to "Float" or "Neutral" to prevent unintended marker operations; unexpected marker operation and flailing equipment can serious injures including death.*



**Pinch, Crush, and Sharp Object Hazards**

*Markers can fall quickly and unexpectedly if the hydraulics fail. Serious injury can result if caught or struck by a moving marker. Never allow anyone near the planter when operating the markers.*

The marker hydraulics are actively energized whenever the fold hydraulics are not activated.

If the planter is equipped with a rear auxiliary hydraulic drive system, set the selector valve (1), near the

sequence valve (2), at the marker base on the left wing to "Marker".

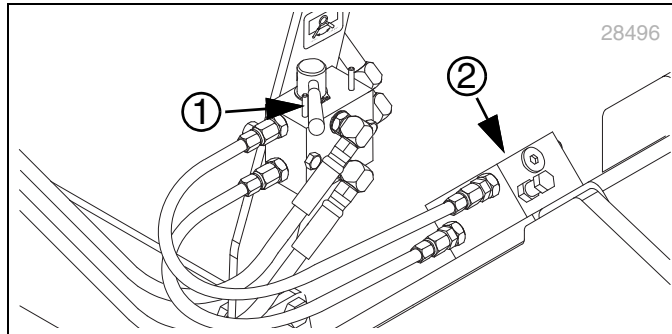

**With IntelliAg ISO6**

1. Use tractor marker circuit lever to operate the markers.

**With Switch Box**



Leave the marker/fold toggle switch in the **MARKER** position for field operations; it will act to lock the folding system.

1. On the switch box, toggle the on/off power switch to **ON**.



2. On the switch box, toggle the marker/fold switch to **MARKER**.



3. Use tractor marker circuit lever to operate the markers.

**Operational Sequence - Dual Markers**

All Planters with Markers

Dual markers are equipped with a sequence valve to control lift sequence. Starting with both markers up, the operational sequence is:

1. Extend tractor hydraulic lever; right marker lowers while left marker stays up.
2. Retract tractor hydraulic lever, right marker raises while left marker stays up.
3. Extend tractor hydraulic lever, left marker lowers while right marker stays up.
4. Retract tractor hydraulic lever; left marker raises while right marker stays up.
5. Pattern repeats.



To move both markers in the lowered position at the same time, activate hydraulic lever to lower one marker. After marker is lowered, move lever to opposite position then quickly reverse lever and hold until the other marker is lowered.

**■ Ground Drive Section Control (Option)**

Section Control will allow for independent control of rows and sections depending on your overall planter configuration.

**With Switch Box**

With ground drive planters configured with section control, the individual left and right electric clutches will allow for the independent control of the left-and-right row sections during field operations. The left clutch will control the left wing row section and the right clutch will control the right wing row section. On planters configured with 16 row configurations, rows 1-8 will be the left-section and rows 9-16 will be the right-section. On planters with 12 row configurations, rows 1-6 will be the left-section and rows 7-12 will be the right-section.

During planting operations, each clutch switch indicates:



- a lit **GREEN** light for active row section, and
- a lit **RED** light for inactive row section.

To select the left row section for active operation:

toggle the left clutch switch downwards; a lit **GREEN** light on the left clutch switch will indicate the necessary selection has been made.



To select the right row section for active operation:

toggle the right clutch switch downwards; a lit **GREEN** light on the right clutch switch will indicate the necessary selection has been made.



### ■ Swath Command™ (Option)

The optional Swath Command™ system replaces the standard 2-section operator-controlled clutches with clutches under console control. There are 8 sections of clutches for 16-row planters, and 6 sections of clutches for 12-row planters.

The Swath Command system automatically turns off rows when the row unit enters a non-planting area, as defined by pre-loaded information, or if the row enters an area already logged as planted during previous passes.

Refer to the Swath Command manual for setup and operation of the system.

1. With your in-cab console, tap the Work Screen softkey from the Home screen.

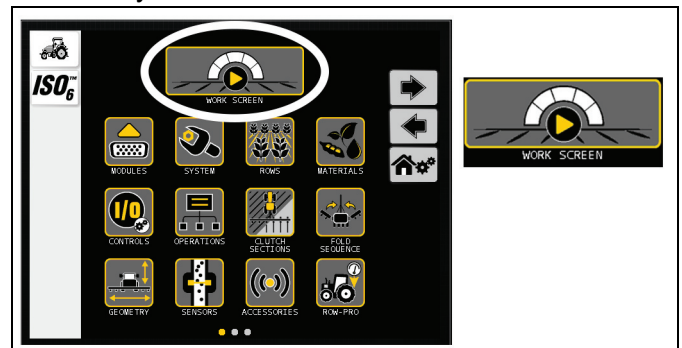

2. Tap the Electric Clutch softkey to be able to set clutches to active or inactive.

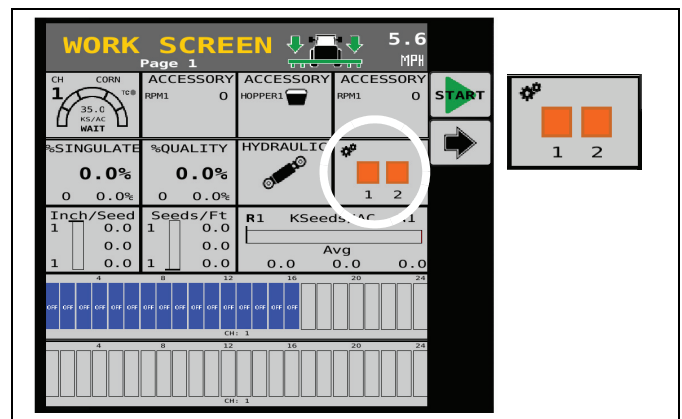

During planting operations, your screen will indicate:

- a **GREEN** box for active row section
- a **RED** box for inactive row section (shown)
- sections will be pre-programmed from left-to-right rows

### ■ Air System - Bulk Seed Hoppers

The air system for a bulk seed hopper planter consists of two hydraulic fans. One hydraulic fan supplies air for the seed delivery and the other hydraulic fan supplies air for meter operation.

Fan rpm is adjusted using the tractor remote hydraulic flow control.

A sensor measures and reports the air readings to the console.



In case of insufficient fan air or significant seed delivery air leaks, seed flow may be irregular or stop.

Some rows have lines to sample metering air pressure which is measured in a sensor chamber.

The sensor reading is fed back to the console for pressure control. Air pressure is adjusted to the preset target in console.

**Seed Delivery Air Flow**

Air flows from the seed delivery fan (1) to the air box (2). That air is mixed with seed from the hopper and flows out the air box manifold ports into seed hoses to the rows.



If seed delivery air flow is insufficient, the indication will be low seed rate alarms. If fan speed and direction are as recommended, check for air leaks in the seed delivery system.

The baffles (3) at the seed delivery air splitter adjust air flow to the air box. See page 42 for adjustment.

A screen (4) above each seed meter vents the delivery air. The vent has two functions:

1. Releases delivery air while retaining the delivered seed.
2. Controls bulk seed delivery.

When the meter inlet is filled and seed fills the tube above the inlet, the screen becomes blocked by seed, shutting off the air flow to that meter. As the meter uses seed, the screen is exposed and air resumes flowing, carrying more seed to the seed meter.



It takes about a minute to initially fill the seed meters.

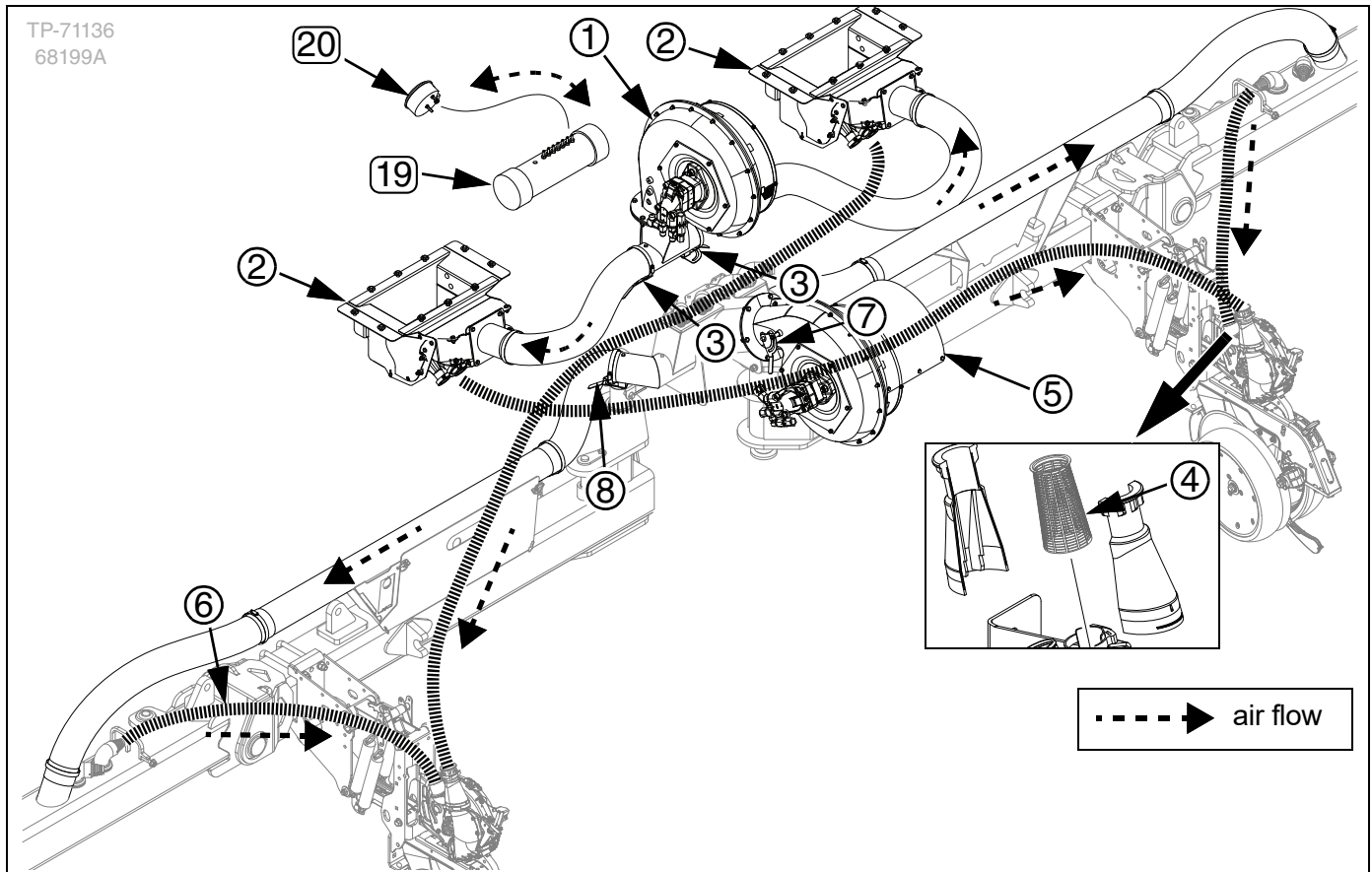

**Seed Meter Air Flow**



**Dealer Servicing and Repair Risk**

Do not adjust balance baffles. The balance baffles are factory set and are not to be adjusted. Any adjustment made will be very difficult to reset to factory setting.



**Material Loss Risk**

Running a seed disk with no seed, or with an open empty inlet, unbalances the air system. Doing either at a sensor row causes the gauge to report incorrectly.

Air from the seed meter operation fan (5) flows to the planter frame. The air then flows out the air outlets to

pressurization tubes (6). The tubes route air to each row unit.

The main baffle (7) on the fan outlet adjusts air flow. See page 42 for adjustment.

**The baffles (8) at the seed meter air splitter balance the air for the wings and center sections. Do not adjust these baffles.**

Seed enters the meter at the seed inlet (9) and forms a seed pool (10) at the base of the meter. The gate handle controls the seed inlet gate (11) and the size of the seed pool. The inlet gate also minimizes air loss back up the seed inlet tube. See page 46 for inlet gate adjustments.

The meter disk is driven by a chain drive connected to the drive shaft, or the IRC.

At the meter, pressurized air exits the meter through the seed cells (12) of the disk, and holds seed in the cells until released above the seed tube (13). Excess seed at a cell is picked off by the tufted brush (14).

The strip (15) and drop (16) brushes block meter pressure air. Seeds passing the drop brush are free to fall into the seed tube.

The seed tube sensor (17) detects passing seeds and reports to the console. Medium size and large seeds are counted individually. For smaller seeds, the seed sensor acts as a blockage indicator.

Several rows have a pressure sensor port (18) for the meter pressure system. A line from each of these rows is connected to a pressure sensor chamber (19) to average the pressures.

The averaged pressure is reported by a pressure gauge (20). See **“Fan Adjustment”** on page 40 for using the gauge to make fan adjustments.



Do not operate in the ground with the fan shut off, or with insufficient air pressure. The meters will completely fill with seed. Meter clean-out may be required to resume normal operation.

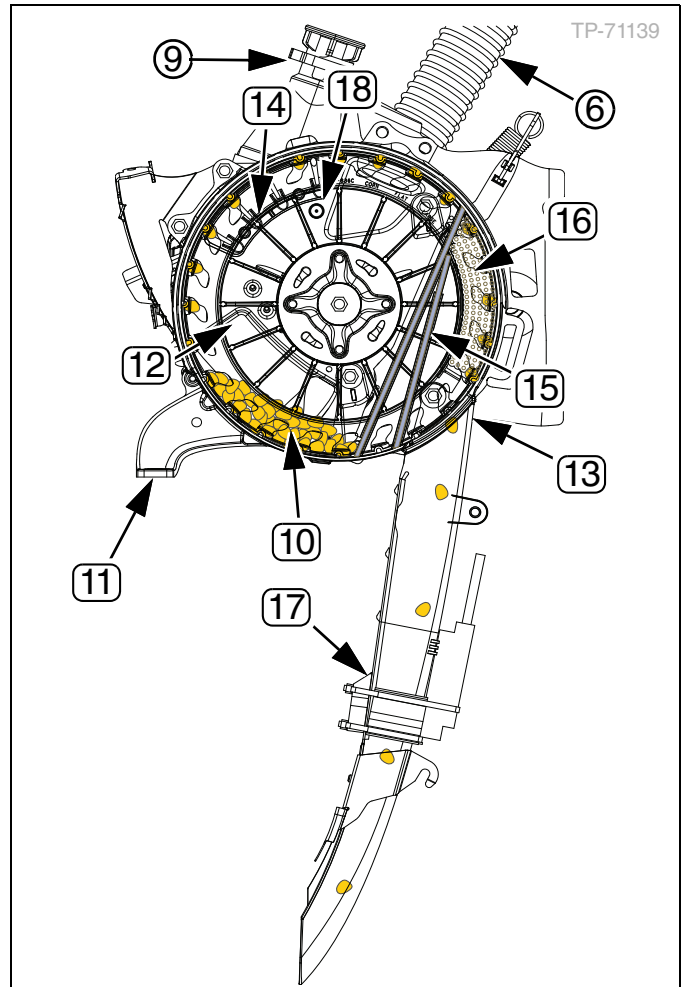

**Fan Hydraulics - Bulk Seed Hoppers**



**Motor Seal Damage Risk**

*Do not apply pressure to the case drain line. Do not change the special quick connector. A restricted or sealed case drain line will promptly result in motor seal damage.*

**Tractor Connections**

Fan hydraulic hose connectors to the tractor:

- 3/4 FORB quick disconnect flatface (1) - case drain connector
- 1-1/16 FORB male quick disconnect (2) - motor return
- 3/4 FORB male quick disconnect poppet type (3) - pressure supply

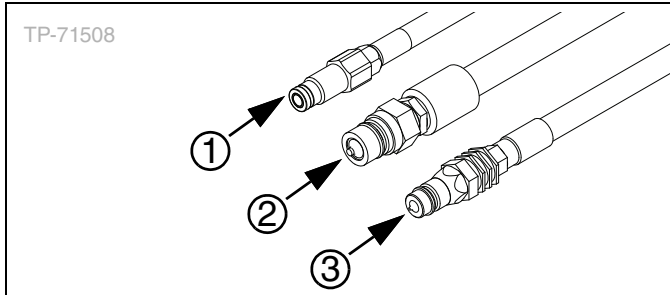

Always connect the case drain hose first.

The case drain (1) hose protects the outer seal of the hydraulic motor. It is a small line to the hitch, supplied with a specialized low-seep, flat-face case drain quick disconnect.

**Fan Hydraulic Hoses**

Hydraulic hoses must be properly connected for the fan to operate in the correct direction, at recommended speed, and without damage.

Hydraulic hose connections to the fans are:

- 9/16 SAE case drain port (A)
- 1-1/16 SAE return port (B)
- 1-1/16 SAE pressure port (C)

Correct air flow (D) is toward the outlet.

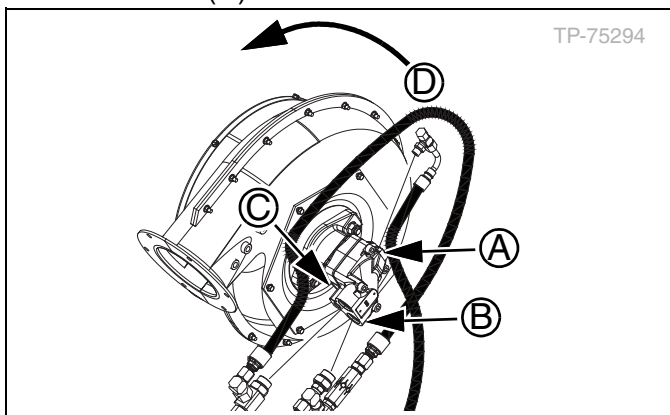

Case drain hose (1) - from the seed delivery fan to the tee behind the motor return and pressure hoses

on the meter operation fan. Then from the tee on the meter pressure fan to the tractor.

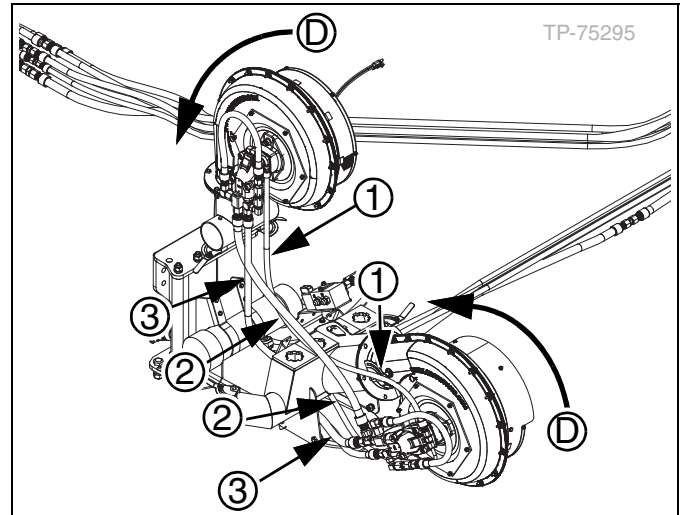

Motor return hose (2) - from the seed delivery fan to the tee on the meter operation fan. Then from the tee on the meter pressure fan to the tractor.

Fan pressure hoses (3).

**■ Air System - Row Hoppers**



**Performance Risk**

*The balance baffles are factory set and are not to be adjusted. Any adjustment made will be very difficult to reset to factory setting.*

A hydraulic fan supplies air for seed meter operation.

Fan rpm is adjusted using the tractor remote hydraulic flow control.

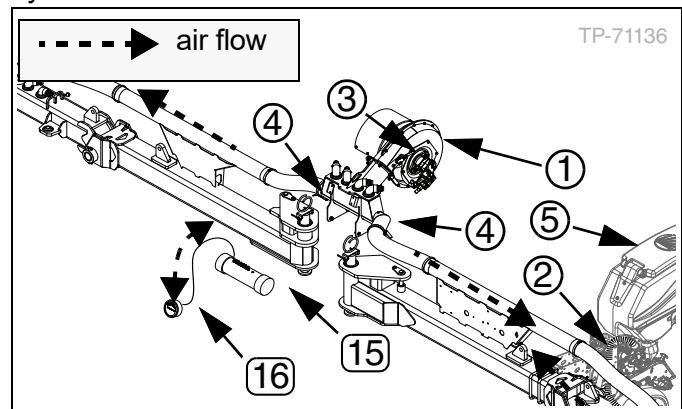

Air from the hydraulic fan (1) flows to the planter frame. The air then flows out the air outlets to pressurization tubes (2). The tubes route air to each row unit.

The main baffle (3) on the fan outlet adjusts air flow. See page 42 for baffle adjustment.

The baffles (4) balance the air for the wings and center sections. Do not adjust these baffles.

Seed is delivered from the hopper (5) by gravity to the seed meter.

Seed enters the meter at the seed inlet and forms a seed pool (6) at the base of the meter. The gate handle controls the seed inlet gate (7) and the size of the seed pool. The inlet gate also minimizes air loss back up the seed inlet tube. See page 46 for gate adjustments.

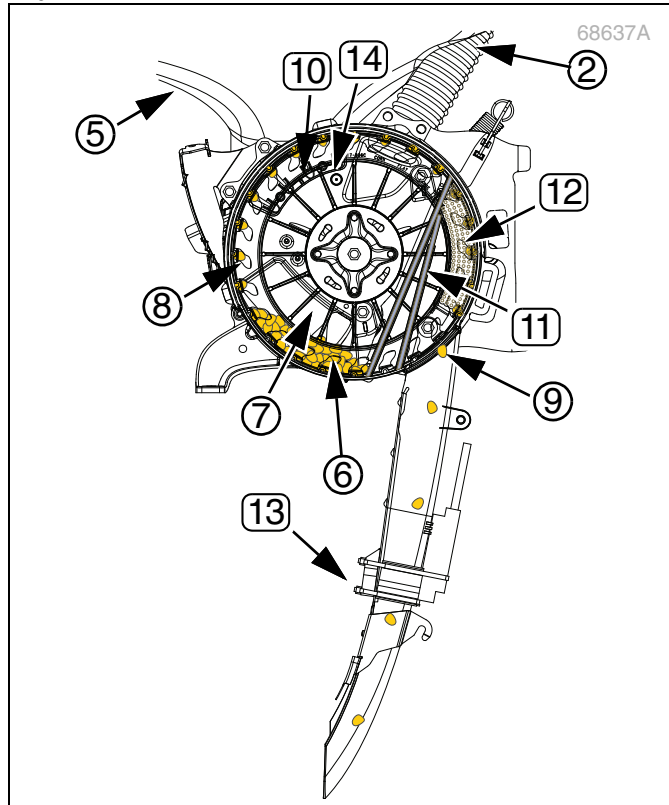

The meter disk is driven by a chain drive connected to the drive shaft or IRC.

At the meter, pressurized air exits the meter through the seed cells (8) of the disk, and holds seed in the cells until released above the seed tube (9). Excess seed at a cell is picked off by the tufted brush (10).

The strip (11) and drop (12) brushes block meter pressure air. Seeds passing the drop brush are free to fall into the seed tube.

The seed tube sensor (13) detects seeds passing and reports to the console. Medium size and large seeds are counted individually. For smaller seeds, the seed sensor acts as a blockage monitor.

Several rows have a pressure sensor port (14) for the meter pressure system. A line from each of these rows is connected to a pressure sensor chamber (15) to average the pressures.

The averaged pressure is reported by a pressure gauge (16). See **“Fan Adjustment”** on page 40 for using the gauge to make fan adjustments.



Do not operate in the ground with the fan shut off, or with insufficient air pressure. The meters will completely fill with seed. Meter clean-out may be required to resume normal operation.

## ■ Fan Hydraulics - Row Hoppers



### **Motor Seal Damage Risk**

*Do not apply pressure to the case drain line. Do not change the special quick connector. A restricted or sealed case drain line will promptly result in motor seal damage.*

### **Tractor Connections**

Fan hydraulic hose connectors to the tractor:

- 3/4 FORB quick disconnect flatface (1) - case drain connector
- 1-1/16 FORB male quick disconnect (2) - motor return
- 3/4 FORB male quick disconnect poppet type (3) - pressure supply

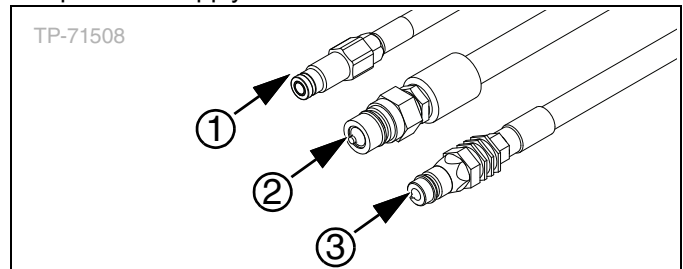

### **Always connect the case drain hose first.**

The case drain (1) hose protects the outer seal of the hydraulic motor. It is a small line to the hitch, supplied with a specialized low-seep, flat-face case drain quick disconnect.

### **Fan Hydraulic Hoses**

Hydraulic hoses to the fan must be properly connected for the fan to operate in the correct direction, at recommended speeds, and without damage.

Hydraulic hose connections to the fan:

- 9/16 SAE case drain port (A)
- 1-1/16 SAE return port (B)
- 1-1/16 SAE pressure port (C)

Correct air flow (D) is toward the outlet.

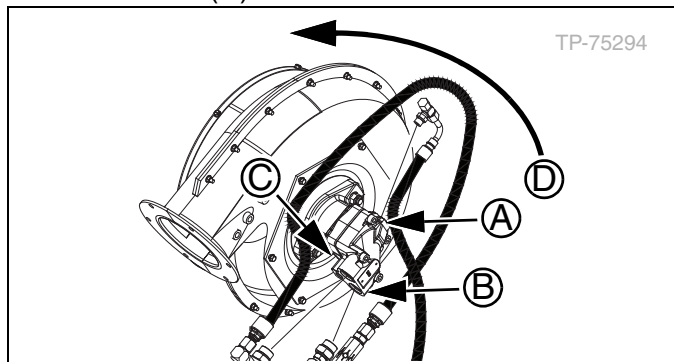

Connect the motor return hose (2) to the sump.

A pressure-relief quick-disconnect coupler for the return line prevents motor damage if the return line is not connected, or is connected incorrectly. However, an oil spill results if the return line is not correctly connected.

Connect the fan pressure hose (3) to a tractor remote. If a priority remote is available, use it for the fan.

## ■ Fan Operation



### **Rotating Fan Blade Hazard**

*The fan accelerates instantly. Body parts and clothing can be drawn into the fan, resulting in serious injury or death. Do not operate the fan with the guard screen removed. Disconnect fan circuit when working on fan.*



### **Low Population Risk at Turns**

*Aggressive lift and lower operations and simultaneous marker operations can reduce fan rpm below that needed to pressurize meter disks. If seed falls out of cells, skips will occur shortly after turns.*

Use the tractor remote hydraulic valve flow control to set fan speed. Always start the fan with a low flow setting. Monitor fan rpm with the console.

Gradually bring the fan up to the recommended initial fan speed - 2800 rpm.

The console and pressure gauge readings should agree within a few tenths of an inch.



The Material Rate manual provides initial values for meter pressurization. Normal readings are in the 0.8 inch to 4.0 inch water pressure range and vary with the crop.

If the tractor has marginal flow available, you may need to experiment with combinations of fan flow and baffle settings.

The fan requires up to 12.5 gal/min (47 liter/min). This does not include oil for lift/lower or for marker operation.

Unless the tractor has generous oil flow capacity, raise/fold markers before lift, and lift slowly. Watch meter pressure and tune operations to keep it at planting levels in turns.

Fan speed can change as oil heats to operating temperature. Check meter pressurization more often during early operations.

Stop the fan by setting the tractor circuit to "Neutral" or "Float". The check valve slows the blades to a stop by locally recirculating the oil.

Check valves provide a relief path for oil at motor shutoff. If hydraulic hoses to the fan are reversed, flow through this valve results in low fan rpm.

If a fan is connected in reverse, it may not run at all due to no oil source at the return connection. If oil is present, oil bypass at the check valve prevents the fan from reaching operating rpms. A reversed fan is not capable of providing enough air flow for planting.

If desired pressure cannot be reached, or requires unusually high oil flow at low baffle settings, the fan may be running backward. On bulk hopper planters, if the rpm and meter pressurization readings are correct, but the seed meters are not getting seed, the fan may be running backward.

When a reversed fan is suspected, observe during shutoff since the direction of the motor is easier to see at lower rpms. Initial startup is instantaneous, which makes observing at startup difficult.

If the fan is found to be running backward, reverse the inlet/return lines at the fan.

## ■ Fan Adjustment

Verify the correct seed disks are installed (see seed rate charts), and the seed inlet gates are set for the seed to be used.

1. For planters with IntelliAg ISO6- With the fan off, check the meter pressurization on the console. Re-zero as needed. Refer to console operator manual.

For planters with the PM300 - With the fan off, observe the mechanical gauge.

2. Determine the recommended meter pressurization. Refer to Material Rate manual.
3. Put the tractor in park and set the brakes.

- 
4. Set the tractor engine speed to typical field rpm. Lift the planter.
  5. For bulk hopper planters - Start the seed delivery fan. Check for meter fill:  
With the fan running and the tractor in park and/or the park brake set, remove several rain covers from the seed meters, and check for seed in the meters by looking through the disks. Check rows with longer hoses and sharper hose bends. If the fan is running and a meter runs out of seed, back-pressure to the air box manifold may prevent prompt refill. To fill a starved meter, close the seed inlet gate for about 15 seconds, then put it back to the original setting.
  6. Start the meter operation fan. Gradually increase fan rpm using the tractor hydraulic flow control for the circuit.
  7. Check that at least a small amount of pressure is being sensed at the meters and meter pressurization is near the suggested value.  
The meter pressurization system cannot reach full operating pressure when the hoses, meters, and disks are completely empty. Low initial pressures are normal.
  8. Fill the meters.
    - a. For electric drive and hydraulic drive - run a *FILL DISK* operation.
    - b. For ground-drive planters - Rotate the ground drive wheel to fill the meters. Meters are filled when seed begins emerging below two or more openers.
  9. Check meter pressurization. With meters and disks filled, meter pressurization should be at target value.  
If pressure is too low, open the main baffle or increase fan speed.  
If pressure is too high, reduce the fan speed or close the baffle slightly.
  10. Begin planting. Troubleshoot any obvious problems or alarms.
  11. After the first pass, take note of the average populations reported on the console:  
If the population is only slightly low, the problem can be skips (periodic empty disk cells). If slightly high, the problem can be doubles (periodic cells with double seed). A meter pressurization adjustment may correct either condition.
- If the reported population varies from the desired population by a significant amount, do the following:
- a. Expose several seeds in each of several rows, being careful not to move them.
  - b. Measure and average the distance between seeds.
  - c. Compare the average to the predicted seed spacing for the population in the Material Rate manual.
  - d. Any instances of no seed where expected may be a sign of skips. Two seeds at the same place indicates doubles.
12. Resume planting. During the next pass, note the following on the console screen:
- *Minimum Row Population*
  - *Maximum Row Population*
- A small variation of population between rows is normal. However, a row consistently running lower or higher than the other rows, could indicate a meter or seed sensor problem that needs attention. See “**Seed Population Troubleshooting**” on page 78.
- When drive sprockets or electronic controls are set correctly and the meter air pressure is adjusted to the recommended setting, planted population on the console should display very close to target with the correct seed disks. If the reading is significantly different, first check that the drive is set properly and the console settings are correct for your seed disk and row spacing. Verify that the speed displayed is calibrated and matches the tractor reading. Verify that meter pressure matches the chart.
- Minor variations may be caused by skips or doubles if all other causes are ruled out. This will affect the overall planter and not just one or two rows. For slightly low population, increase meter pressure to eliminate excess skips. For slightly high population, decrease meter pressure to eliminate excess doubles.
- After adjustment, always check the planting rate following the procedure in the Material Rate manual to verify correct operation.

## Adjusting for Skips

If everything else is correct, and the overall average population is running low, or there are gaps when doing a furrow check, seeds may be falling out of disk cells before delivery to the seed tube. Increase meter pressurization to correct this.

Insufficient meter pressurization, or unusually rough fields can increase the incidence of empty cells. Be sure to rule out other causes, such as skipping chains, meter starvation, or incorrect meter disks, before adjusting meter pressurization to reduce skips. Excess meter pressurization can increase the chance of doubles.

Before adjusting meter pressure, first verify that the drive is set, seeds per revolution is set, tires are correctly inflated, and all mechanical settings are correct.



Meter pressurization can be adjusted with the planter in motion.

### To increase meter pressurization:

1. Adjust hydraulic flow to meter pressure change.
2. Wait 5 to 10 seconds for the system to update while you continue planting.
3. Continue making small adjustments until the reported population levels out at the target value.

## Adjusting for Doubles

If everything else is correct, and the overall average population is running high, or there are double seeds when doing a furrow check, the cause may be two seeds in some disk cells at delivery to the seed tube. Decrease meter pressurization to correct this

### To decrease meter pressurization:

1. Adjust the tractor hydraulic flow.
2. Wait 5 to 10 seconds for the system to update while you continue planting.
3. Continue making small adjustments until the reported population levels out at the target value.

## Fine-Tune Meter Pressurization

After several passes with satisfactory planter operation, fine-tune meter pressurization. During longer passes, with fewer distractions:

1. Observe the current overall average population from the console.
2. Adjust the meter pressurization down in small increments. Wait 5 to 10 seconds between

adjustments, until skips occur (actual population begins falling below target). Note the pressure where skips begin.

3. Restore the pressure to the initial value at step 1.
4. Adjust the meter pressurization up by small increments until doubles occur (actual population begins rising above target). Note the pressure at which doubles begin.
5. Adjust meter pressurization to a value halfway between the limits from step 2 and step 4. This is the ideal value for your crop, disk, and population, providing equal margin against skips and doubles. Record this value for future use.

## Alternate Skips/Doubles Check

Small seeds, particularly milo, and high populations particularly soybeans, may not be sensed as skips or doubles by the seed tube sensors, and watching console population is unlikely to locate the pressure limits. The following test can also be quicker for all seeds:

1. After planting a few passes with initial settings, remove the rain covers from several seed meters. Use rows with a variety of seed hose lengths and routes.
2. Make a meter pressurization adjustment, and resume planting for a pass or less.
3. Stop the planter motion but leave the fan running.
4. Inspect the seed disks closely. Look for empty seed cells (skips) and cells with multiple seeds (doubles).
5. Repeat steps 2 through 4 until limits are established. Record the limits and calculate an average.
6. Install the rain covers and plant with the calculated average.

## Baffle Adjustment

**Planters configured with bulk seed hoppers and main baffles.**



### Dealer Servicing and Repair Risks

*Do not adjust balance baffles. The balance baffles are factory set and are not to be adjusted. Any adjustment made will be very difficult to reset to factory setting.*

**To adjust baffles:**

1. Loosen the bolt (1).

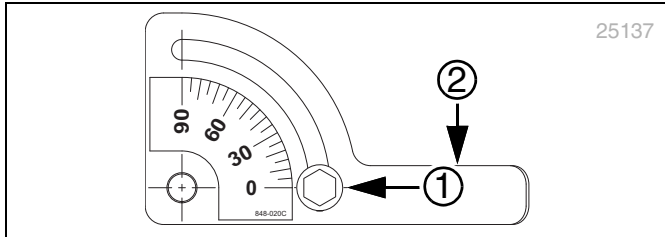

2. Rotate the handle (2) to adjust.
3. Tighten the bolt (1).

**Baffle settings:**

- 90° is closed - minimum air flow.
- 0° is wide open - maximum air flow.

**■ PM300 Seed Monitoring System (Option)**

The PM300 Seed Monitoring System is an option for ground drive planters. Installation instructions for the console is included in the PM300 operator manual. PM300 Seed Monitoring System will report the following information on the console:

- ground speed,
- up to two hopper levels, and
- seed rate at each row unit seed tube.



Medium and large seeds are individually counted with high accuracy. Small seeds, such as Milo, may be more difficult to sense, and instead, the seed monitoring system will indicate seed blockage.

Three inputs are required before beginning planting operation:

- number of rows,
- row spacing, and
- the ground speed constant.

Selecting a factory programmed planter configuration will provide:

- planter row width,
- number of rows,
- implement width, and
- row types.

To save time, prior to field use, up to three planter configurations may be entered in the console for the seed monitoring system. See Material Rate manual for values.

For in-cab console operation instructions, see Dickey-john Operator manual (11001-1372).

**■ Seed Lubricants**



**Irritation and Chronic Exposure Hazards**

Seed lubricants may cause eye or skin irritation in high concentrations. Prolonged inhalation may cause lung injury. Product can become slippery when wet. Wear gloves and a respirator when transferring and mixing seed lubricant. Do not use bare hands or any part of your body to mix. Avoid breathing lubricant dust. Follow chemical manufacturer's precautions when handling items that may be coated with treatment. Use proper skin, eye, and respiratory protection.



**Dust and Explosion Hazards**

Avoid creating dust in any confined space with ignition sources present in specific concentration can be explosive. Avoid exposure to dust when missing this powder into seed. Consult the instruction booklet and Safety Data Sheet (SDS) for more information.

To maximize the performance of the metering systems, it is imperative to use Ezee Glide Plus or Bayer Fluency Agent Advanced. Proper use of seed lubricants will decrease wear in the seed meters and helps to prevent clumping, bridging, and clinging of seed. It is key to premix the seed lubricant into the seed so that each seed is evenly coated. Only mixing seed into the top layer of the bulk seed hopper will not be effective.

**Ezee Glide Plus**

**Talc-Graphite Mix**

Ezee Glide Plus seed lubricant is suitable for all seeds, especially treated or inoculated seed, except where talc and graphite mixes are prohibited or not advantageous. Thorough mixing of seed and added seed lubricant is required.



**Recommended usage:**

Clean Seed Type	Ezee Glide Plus
Milo	1 cup per 2 bushels 335 ml per 100 liters
Cotton	1 cup per 2 bushels 335 ml per 100 liters
Sunflowers	1 cup per 2 bushels 335 ml per 100 liters
Mustard	1 cup per 30 pounds 240 ml per 13.6 kg
Canola	1 cup per 30 pounds 240 ml per 100 liters
All other seed	1 cup per 4 bushels 170 ml per 100 liters

Adjust this rate as necessary so all seeds become evenly coated while avoiding an accumulation of lubricant in the bottom of the hopper.

For seed with excessive treatment, or for humid planting environments, increase the rate as needed for smooth seed meter operation.

**Bayer Fluency Agent Advanced**

This agent is required by regulation for certain crops in certain regions; such as corn and soybeans in Canada. It is an alternative to Ezee Glide Plus in other locales, for large seeds. It is not recommended for small seeds such as canola and milo.

Refer to the booklet attached to the bucket for recommended usage. Do not exceed recommendations, as excess amounts adversely affect accurate seed metering.



**■ Rear Auxiliary Hydraulics (Option)**



**Flailing Equipment Hazard**

*Do not switch the auxiliary selector valve until the tractor fold/marker circuit is set to “Neutral” or “Off” or unexpected movement of the marker or wings may occur causing machine damage, serious injuries, and even death.*



**Flailing Hazard**

*Marker hydraulics are active whenever the fold hydraulics are not in use. It is important to set the tractor fold/marker hydraulic circuit lever to “Float” or “Neutral” to prevent unintended marker operations. Unexpected marker operation and flailing equipment can seriously injure including death.*

The optional auxiliary hydraulic kit includes a manual valve that diverts the marker/fold hydraulic circuit to a pair of quick-connect ports at the back of the planter.

1. If equipped, fully fold markers.
1. Set tractor fold/marker circuit lever to “Off”.
2. Close any shut-off valve on the auger and connect the auger to the auxiliary quick-connect ports at the rear of the planter.
3. At the auxiliary selector valve, move the handle from Fold to Auxiliary.
4. With no seed present, open the auger shutoff valve, and operate the cab control to determine which setting (extend or retract) turns the auger in the correct direction for seed lift.
5. Load the seed.
6. Set the tractor circuit to “Off”, and then turn the auger off.
7. Return the auxiliary selector valve handle to “Marker”.
8. Disconnect the auger hydraulic hoses at the auxiliary ports.

**■ Material Loading**



**Agricultural Chemical Hazard**

*Read and follow all supplier cautions for safe handling of treated seed.*



**Irritant Exposure Hazard**

*Do not mix lubricants into seed with hands or any part of body. Wear protective equipment. Use tools.*

## Bulk Seed Hoppers



### **Entrapment and Suffocation Hazard**

A seed hopper that is full, or appears full, can be an entrapment hazard. You can sink all the way into the grain and suffocate in a matter of seconds. Never enter a seed hopper for loading, unloading, or routine maintenance. Keep lid tightly closed during operation.

Seed is loaded into the bulk seed hoppers from above.

1. Lift the handle (1).

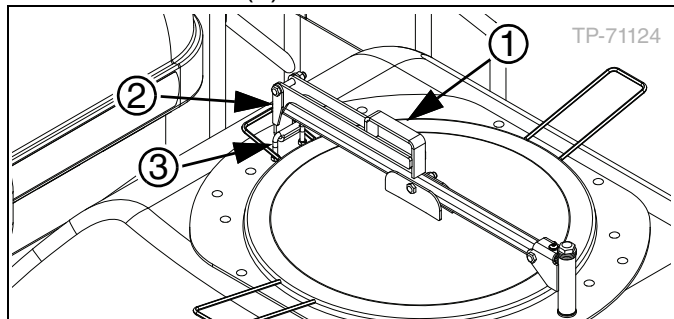

2. Swing the handle out until the hook (2) releases from the u-bolt latch (3).
3. Move the hook clear of the latch.
4. Lift lid slightly at the pivot end to clear the strainer (4).
5. Swing lid away from the opening.
6. Inspect the hopper to verify it contains only the expected material.
7. Load the seed.
8. If equipped, verify the bulk hopper level sensor is connected to the console harness.
9. Close and latch lid(s).
  - a. Swing lid over opening until the hook is centered on the u-bolt latch.
  - b. Open the handle and engage the hook on the latch.
  - c. Close the handle.

## Row Hoppers

Two different sizes of row hoppers are available - 3.0 bushel and 1.6 bushel. The process for loading both hoppers are the same.

1. Check that each hopper is correctly seated and mounting bolts are secured. Ensure the hopper discharge opening is aligned with the seed inlet tube.
2. Clean out any leftover seed and debris in the hopper.

3. Install the correct seed disks.
4. Premix seed and Ezee Glide Plus lubricant. See “Seed Lubricants” on page 43.

If unable to premix before loading, premix at least one gallon (4 liters) per hopper, and load this seed first. Fill the hoppers to half full with fresh seed. Add half the lubricant and stir with a tool. Complete filling the hoppers and sprinkle the remaining lubricant on top.

5. Add seed and lubricant to hoppers.
6. Close lids and latches.

## ■ Seed Meter Setup and Adjustments

The only seed meter adjustments are for the seed inlet gate, a choice of disks, and meter pressure.

### Seed Meter Rain Cover

The rain cover keeps side winds from pushing seed out of the disk cells. It also keeps precipitation, sunlight, and field debris out of the meters. It acts to direct any dust or debris coming from the seed downward toward the soil. A knockout brush on the inside of the cover brushes loose seeds off the seed disk.

To remove the rain cover:

1. Unclasp the latches (1 and 2).
2. Pivot the cover forward and down at the tab (3) and remove.

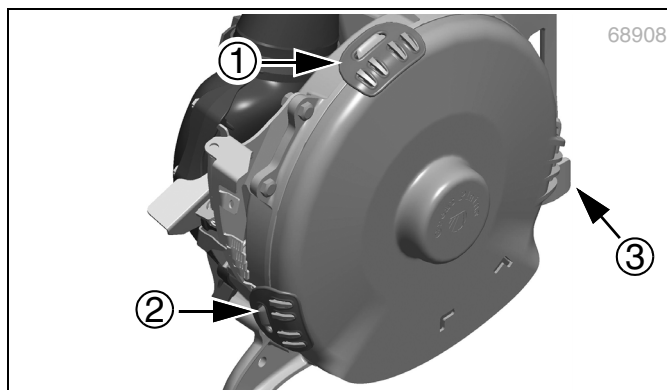

When removing a cover, inspect it for damage and missing parts. If a cover does not have both latches it can be lost during transport or field operations. Also, inspect the knockout brush for wear.

To replace a latch, slide the replacement latch onto the cover lugs from the meter side, then snap the other end down over the lugs.

To replace the knockout brush, see “Knockout Brush Replacement” on page 67.

**Seed Disk Installation**



**Population Risk**

Verify the same disk is installed in all active rows. Inspect disks for damages or wear which can cause irregular seeding and/or off population.

1. Check the part number and description on the seed meter disks against the seed rate chart data.
2. Before installing, inspect the disks. Do not install damaged or worn disks which can cause irregular seeding. Chips and cracks can increase brush wear.
3. Remove the meter rain cover.
4. Inspect the meter and brushes. See page 65 for details.

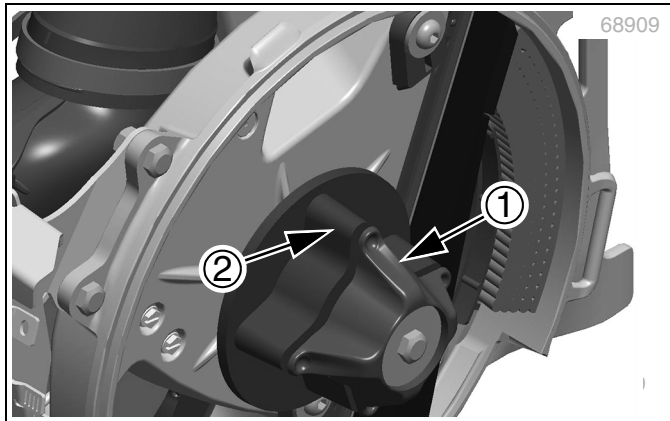

5. Ensure the seed meter clamp (1) is aligned with the disk seat (2).
6. With the seed cells side facing the meter housing, place the new seed disk on the disk seat.
7. Rotate the seed meter clamp (1) clockwise 45° to clamp the disk. The clamp will seat into the seed disk hub (2).

With a new meter or new brushes, force the disk into the brushes to position the seed meter clamp. The brushes will be trained during initial rotations.

With slightly used brushes, when a disk is first clamped, the disk hub may be flat with the disk seat only on the gate side. The disk should seat as it first turns. This condition will ease as the brushes are used.

8. Rotate disks forward a few turns after disk installation to ensure the meter brushes lean in the correct direction. This is particularly important

for new brushes. It will improve meter performance and reduce air consumption.

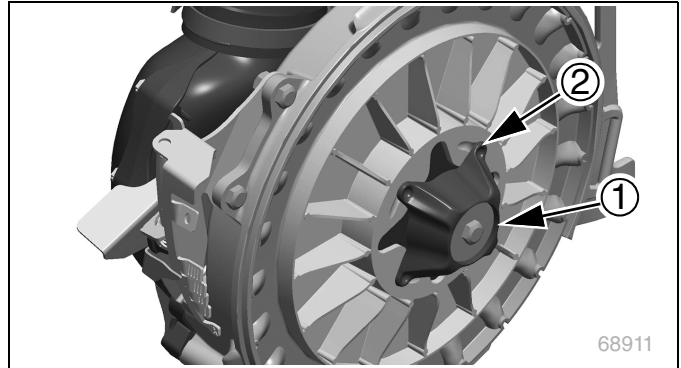

9. Set the seed inlet gate to the setting on the seed rate chart.
10. On the console, select the new Material, seed disk Cell Count, and target population.
11. Reinstall the rain cover.

**Seed Disk Removal**

1. Remove the rain cover. If seed is present, close the seed inlet gate to prevent more seed from entering the meter.
2. Attach the seed container, stored at the left end of the planter, to the seed meter or place a tarp under the row unit to collect the seed.
3. Hold the seed disk and rotate the seed meter clamp (1) counterclockwise 45° to release the disk.

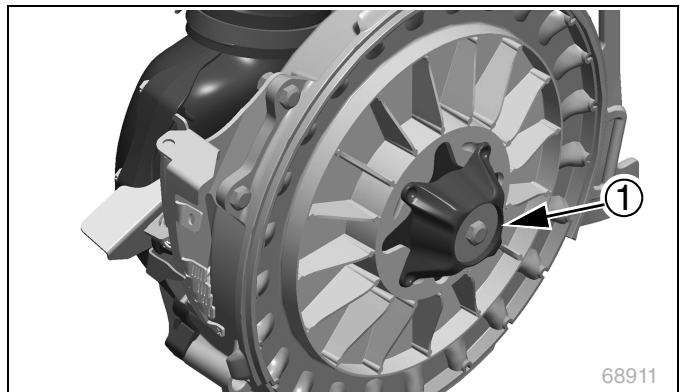

4. Tilt the top of the seed disk toward the meter and slowly remove the disk, allowing seed to collect in the container or on the tarp.
5. Open the seed inlet gate to release the remaining seed.
6. Clean the seed from all brushes. Inspect brushes for excess wear and damage, see “Seed Meter Brush Replacement” on page 66.
7. Clean disk seat so new disks can fully seat.

8. Inspect removed disks for excess wear and damage, see “Seed Disk Maintenance” on page 68. Set aside any disks requiring replacement.
9. Clean seed disks and place in storage.
10. Install the rain covers.

**Seed Inlet Gate Adjustment**

The seed inlet gate (1) controls the volume of bulk seed at the seed disk. The settings vary with crop, seed size, and seed treatment. The gate has settings for row shut-off for completely closed, and clean-out for wide open.

The seed rate charts include suggested initial gate settings. Refine these settings based on the slope of the seed pool at the bottom of the seed disk and flowability of seed.

Coarse seed treatments may require a larger opening.

Do not adjust more than two positions different than the seed rate chart.

To adjust the seed inlet gate, squeeze the tabs (2) and move the gate up or down as necessary. There are four settings for the gate; I, II, III, IIIII.

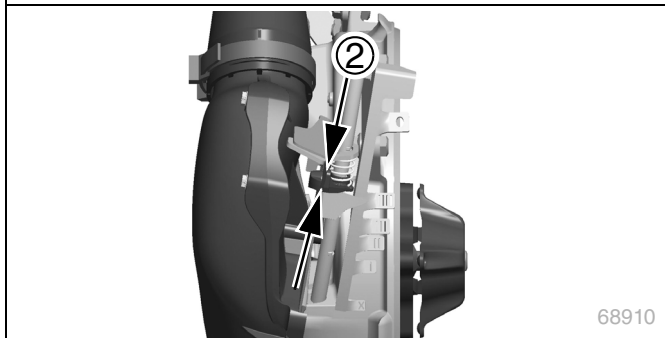
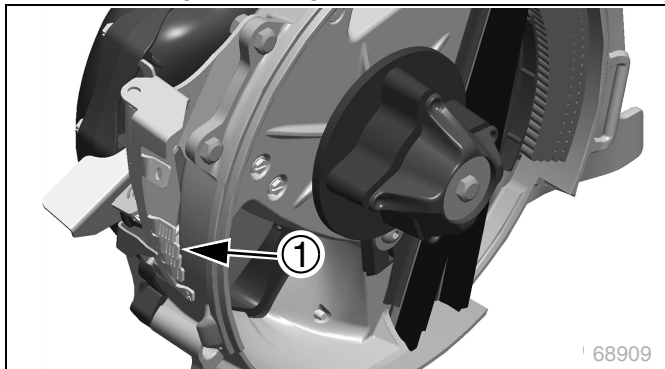

The table below is a general summary of gate settings.

Setting	Setting Typically Used For
X	Closed - row shut-off, meter refill
I	Small seeds, such as milo, with little or no treatments
II	Small treated seeds and edible beans such as soybeans
III	Corn, round popcorn
IIII	Large corn, heavily treated corn
O	Wide open - clean-out

**Seed Pool Slopes**

The best seed pool slope results in the most consistent seeding with minimal skips and doubles. The illustrations below are found to be the best seed pool slopes for sample seeds.

Adjust the seed inlet gate if the suggested setting does not work for your seed.

For medium size and smaller seeds that flow easily, the slope runs from just above the 8:00 position on the housing wall, down to one or two seeds deep at the base of the rear strip brush (1).

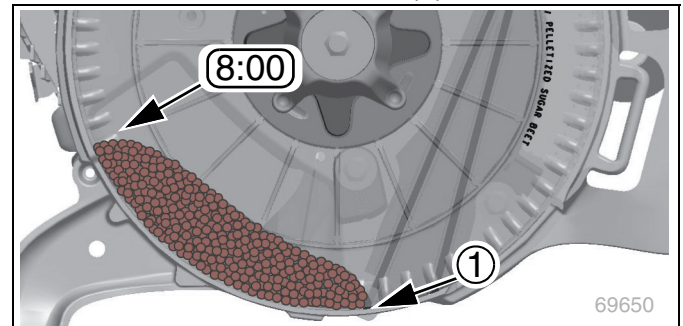

For medium size and larger, or heavily treated smaller seeds that flow less easily, the slope runs at or slightly above the 8:30 position on the housing wall, down to three to six seeds deep at the base of the rear strip brush (1).

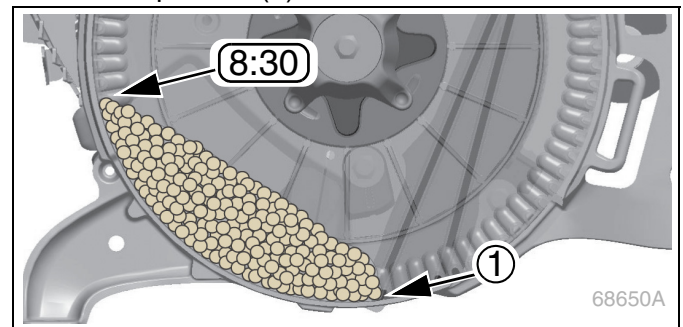

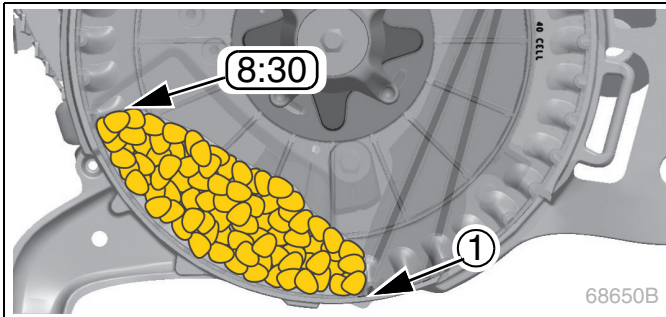

Keep the top left/rear end of the pool below the 9:00 position; meter horizontal center-line.

In general, the seeds at the base of the strip brush need to be deep enough that no air escapes, and that just enough seeds are present to begin populating the cells.

### ■ Seed Meter Operation

1. Install disks for your crop/population range according to the Material Rate manual and the instructions beginning on page 45 of this manual.
2. Open the gate at the planting rows to the recommended initial setting from the seed rate charts.
3. Operate the fan to achieve the suggested air pressure.
4. With all rows primed, rotate meters one turn to fill the cells to the edge of the drop brush. Rotate the drive shaft (top forward) with a 7/8 inch wrench, or raise and rotate the ground drive wheel (top forward).
5. Leave the fan running to keep seed in top cells.
6. Install rain covers.

Begin planting. Meter operation is automatic from this point on.

### ■ Hydraulic Drive



#### **General Warning Hazard**

*Watch your surrounding at all times. Do not operate with bystanders nearby.*

The hydraulic drive uses a hydraulic motor (1) as the power source for meter rotation.

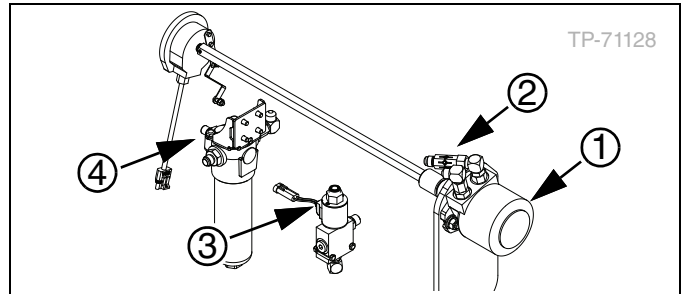

The drive requires a separate closed center hydraulic circuit capable of 4.5 gal/min (17 liters/min). A check valve (2) at the motor prevents reverse operation in case the connections are reversed at the tractor or the circuit lever reversed.

A solenoid valve (3) controls flow to the motor.

A filter (4) in the system requires periodic maintenance.

Refer to the console manual for more information.

When the planter is raised in normal field operation, the lift switch causes the console to shut off hydraulic flow to the motor. Override this shut off and operate the drive while raised using special console modes as follows:

- In User Level 1, the FILL DISK operation runs the motor for one meter disk revolution.
- In User Level 2, the 5 REV TEST operation runs the motor for five meter disk revolutions.

### ■ Setting Planting Rate



#### **Population Target Risk**

*Tire pressure is important for both ground and hydraulic drives. Incorrect tire pressure causes incorrect ground speed readout. On ground drive, incorrect pressure causes incorrect or inconsistent seed metering.*

- Prepare seed meters including disks, gates, and meter pressurization.
- Check tire pressure.
- Check planting rate.

### Ground Drive Planters

#### With 30 inch Row Spacing

Adjust range and transmission sprockets.

**Range Sprockets**

1. Select the range sprockets for your seed and rate from the charts in the Material Rate manual.
2. Loosen the idler (1) and remove the drive chain.

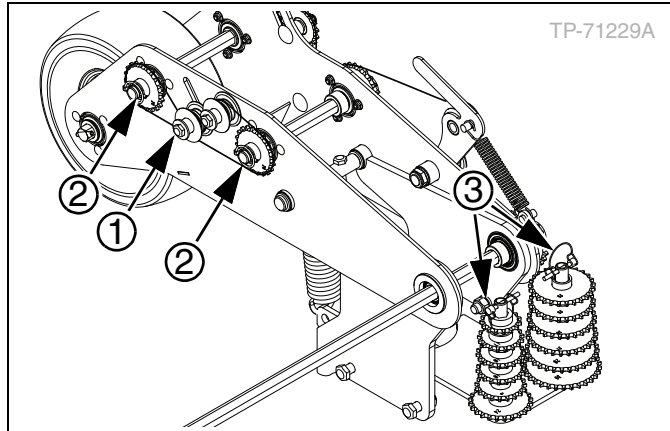

3. Remove the pins from the sprockets (2) and (3) and at storage towers (4).
4. Exchange the sprockets to match the seed rate chart.
5. Install the pins on the sprockets. Store and pin the removed sprockets on the storage towers.
6. Reroute the chain and tighten the idler.

**Transmission Sprockets**

1. Select the transmission sprockets for your seed and rate from the Material Rate manual.
2. Pull the idler handle (1) to remove the chain.

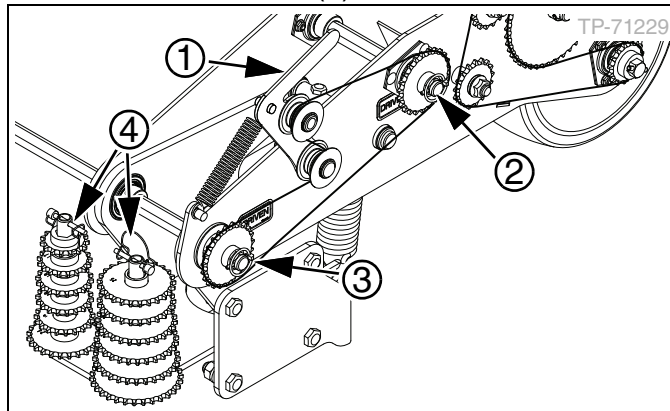

3. Remove retaining pins from DRIVING (2) and DRIVEN (3) sprockets and at the storage towers (4).
4. Exchange sprockets so the new DRIVING and DRIVEN sprocket tooth counts match the seed rate chart.
5. Install the pins on the sprockets. Store and pin the removed sprockets on the storage towers (3).

6. Reroute the chain and engage the idler.

**With 70 cm Row Spacing**

Adjust range and transmission sprockets.

**Range Sprockets**

1. Select the sprockets for your seed and rate from the Material Rate manual.
2. Remove the three pins (inset) to remove the chain cover. Set aside.

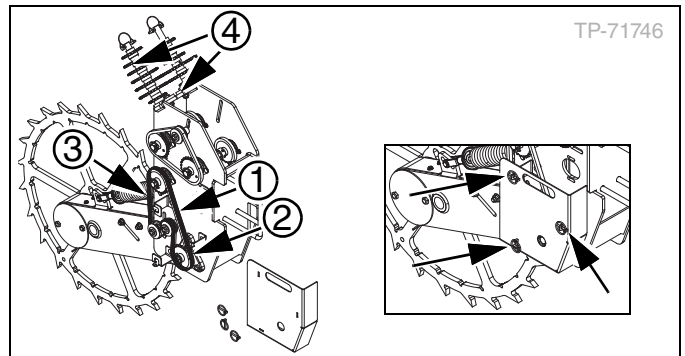

3. Remove retaining pins from DRIVING (2) and DRIVEN (3) sprockets and at the storage towers (4).
4. Exchange sprockets so the new DRIVING and DRIVEN sprocket tooth counts match the seed rate chart.
5. Install the pins on the sprockets. Store and pin the removed sprockets on the storage towers.
6. Reroute the chain and engage the idler.
7. Install the chain cover and insert the three pins to secure.

**Transmission Sprockets**

1. Select the transmission sprockets for your seed and rate from the charts in the Material Rate manual.
2. Loosen the idler (1) and remove the drive chain.

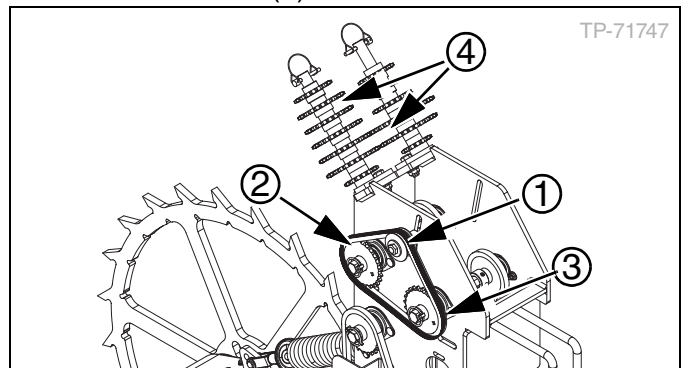

3. Remove retaining pins from DRIVING (2) and DRIVEN (3) sprockets and at the storage towers (4).
4. Exchange the sprockets to match the seed rate chart.
5. Install the pins on the sprockets. Store and pin the removed sprockets on the storage towers.
6. Reroute the chain and tighten the idler.

**Contact Drive Wheel**



**Rate Mismatch Risk**

*Tire pressure matters; ensure the tires are properly inflated before making any adjustments. An incorrect tire pressure causes incorrect or inconsistent seed delivery.*



**Planter Damage Risk**

*Do not adjust the down pressure spring so tight or the travel distance so long that the planter will bottom out when the planter is fully raised.*

The contact wheel drives the seed metering system on a ground drive planter. Contact drive wheels travels in the opposite direction of the main transport tires. The contact travel distance and down pressure spring needs to be adjusted before planting. You can adjust the distance between the contact wheel the main transport tires. You can adjust the down pressure the contact wheel exerts by adjusting the down pressure spring.

Before any adjustments are made on the contact wheel drive, you must ensure the tires are properly inflated.

**Travel Distance**

Adjust wheel travel distance to obtain an 1 1/2 inches contact wheel clearance (A) above the main transport tires.

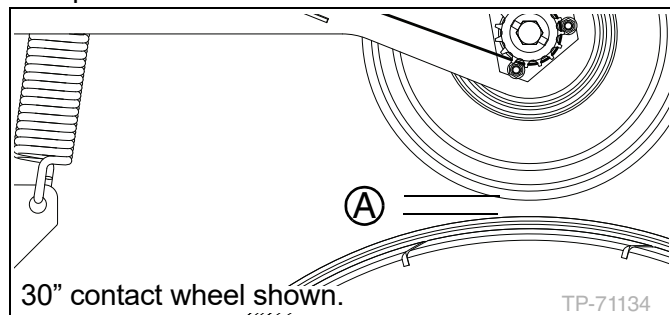

The contact wheel controls the timing of the seed meter drive when raising and lowering the planter. Increasing the gap between the contact wheel and the main transport tire causes the seed flow to start

and stop at a lower planter height. Decreasing the gap will cause seed flow to start and stop at a higher height.

**Travel distance adjustment for 30” row spacing:**

1. Fully raise the planter to ease adjustment.
2. Park the planter on level, even ground.
3. Turn off tractor, set park brake, and remove the key.
4. Ensure the tires are properly inflated. See “**Tire Information**” on page 118.
5. Loosen the two bolts (1) on the top of the down spring assembly to extend the length of the shaft or tighten the two bolts (1) on the top of the down spring assembly to shorten the length of the shaft.

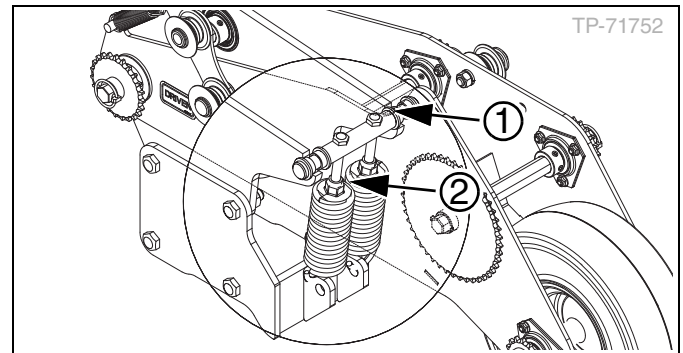

Make contact wheel travel distance adjustment before adjusting the down pressure spring.

**To adjust the down pressure spring for 30” row spacing:**

1. Fully raise the planter to ease adjustment.
2. Park the planter on level, even ground.
3. Turn off tractor, set the park brake, and remove the key.
4. Ensure the tires are properly inflated. See “**Tire Information**” on page 118.
5. Use a hand tool to loosen or tighten the nuts (2) on the top of each spring to desired tension. Loosening the nuts will decrease down spring pressure. Tightening the nuts will increase down spring pressure.

**Travel distance adjustment for 70 cm row spacing:**

1. Fully raise the planter to ease adjustment.
2. Park the planter on level, even ground.
3. Turn off tractor, set park brake, and remove the key.

4. Ensure the tires are properly inflated. See “**Tire Information**” on page 118.
5. Loosen or tighten the adjustable yoke end (3) on the bottom of the down spring assembly to lengthen or shorten the shaft.

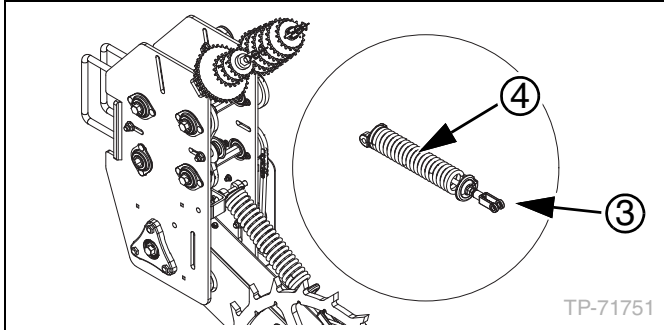

Make contact wheel travel distance adjustment before adjusting the down pressure spring.

#### To adjust the down pressure spring for 70 cm row spacing:

1. Fully raise the planter to ease adjustment.
2. Park the planter on level, even ground.
3. Set the park brake, turn off the tractor, and remove the key.
4. Ensure the tires are properly inflated. See “**Tire Information**” on page 118.
5. Use a hand tool to loosen or tighten the nuts (4) on the top of each spring to desired tension. Loosening the nuts will decrease down spring pressure. Tightening the nuts will increase down spring pressure.

#### Hydraulic Drive or IRC Planters

Set console and drive control channel. See console manual for details.

#### Check Planting Rate

Always check seed delivery rate before planting.

The console can count most singulated seeds, but may not accurately count the smallest seeds, such as canola. It does not count individual volumetric seeds.

Rate checking is described in detail in the Material Rate manual. The following is an overview of the general process, which varies with the seed type and planter meter drive type.

Before checking the rate, verify the console is configured with an accurate Ground Speed Constant.

At the start of each season, perform a *GROUND SPEED CALIBRATION* over 400 ft (100 m), as described in the console manual. When completed and entered in the console, check the reported implement speed against the tractor speedometer or other reference.

#### Singulated Rate

A furrow check is the most accurate way to verify seeding is at the desired population. This is done by planting for a short distance with one or two rows set to shallow depth and with press wheels tied up so furrows do not close.

Seeds are counted in the furrow over a specific distance and the area rate is calculated. Refer to the Material Rate manual for details.

The console will also be counting during the test. Compare the results.

If the checked rate varies from the chart rate or programmed rate, there may be a configuration error that requires correction. Do not calibrate to correct unexpected variations in singulated rates.

#### ■ Height Switch

The height switch informs the console if the planter is raised or lowered. On all planters, the console only counts seed when the planter is lowered and the drive is activated. On hydraulic and electric drive planters, the height switch also enables or disables the drive.



When the hydraulic drive planter is raised, the switch state is ignored during *FILL DISK* and *5 REV TEST* operations.

#### To adjust the height switch:

1. Lower the planter to the height at which seed delivery should begin.
2. Loosen the nut (1) on the height switch.

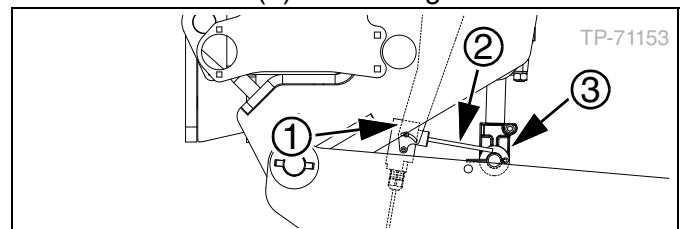

3. Rotate the switch until the spring actuator (2) touches the cylinder pin (3).
4. Rotate the switch in until it clicks. Tighten the nuts to secure the bracket.

## ■ 5000 Series Row Unit

Down-pressure cam (1) - A row unit is mounted on parallel arms, allowing the row unit to move up and down while staying horizontal. Springs set by a cam add an adjustable force to the row weight.

Pressurization air inlet (2) - Pressure-regulated air enters the meter here and holds seed in the disk cells. See **“Fan Adjustment”** on page 40.

Seed inlet (3) - Gravity carries the seed into the meter at the seed inlet gate. For bulk hopper planters, air carrying the seed is vented at the bottom of the air release cone. Remove the hose for inspection. There are no adjustments.

Seed meter (4) - see **“Seed Meter Setup and Adjustments”** on page 45.

Seed inlet gate (5) - This controls the level of bulk seed at the disk. There are four operating settings, plus fully closed for shut-off or storage. See **“Seed Inlet Gate Adjustment”** on page 46.

Side depth wheel - The T-handle (6) sets the planting depth by controlling the height of the side depth wheels relative to the opener disks. See **“Planting Depth”** on page 54.

Press wheels (7) - The press wheels close the furrow, pressing the soil over the seed to provide good seed to soil contact. See **“Press Wheel Adjustments”** on page 56. A variety of press wheels are available, some are region-specific. Consult your Great Plains dealer.

Row cleaner (8) - Optional row cleaners clear trash from the row, to a depth set by an adjustment on the arms.

Unit mount coulter (9) - Optional unit mount coulters cut remaining trash and begin opening the seed furrow. Working depth is set by row depth and a mounting hole selection. See **“Check the new height measurement.”** on page 58.

Opener disks (10) - Row unit double disk openers create the seedbed furrow with adjustments for angle and spacing. See **“Row Unit Opener Disks”** on page 54.

Seed tube with sensor (11) - Requires no adjustment.

Scrapers (12) - Optional inside scrapers require no adjustment. For side depth wheel scrapers, see **“Depth Wheel Scrapers (Option)”** on page 56.

Seed firmers (13) - The seed firmer minimizes seed bounce and improves soil contact. It may also deliver fertilizer. see **“Coulter Row Alignment”** on page 59. The seed flap is standard. The Keeton® seed firmer (shown) is optional.

Disk scraper/separator (14) - The scraper/separator can also place liquid fertilizer under the seed.

Side depth wheel contact adjuster (15) - see **“Side Depth Wheel Adjustments”** on page 54.

Press wheel centering adjuster (16) - see **“Press Wheel Centering”** on page 56.

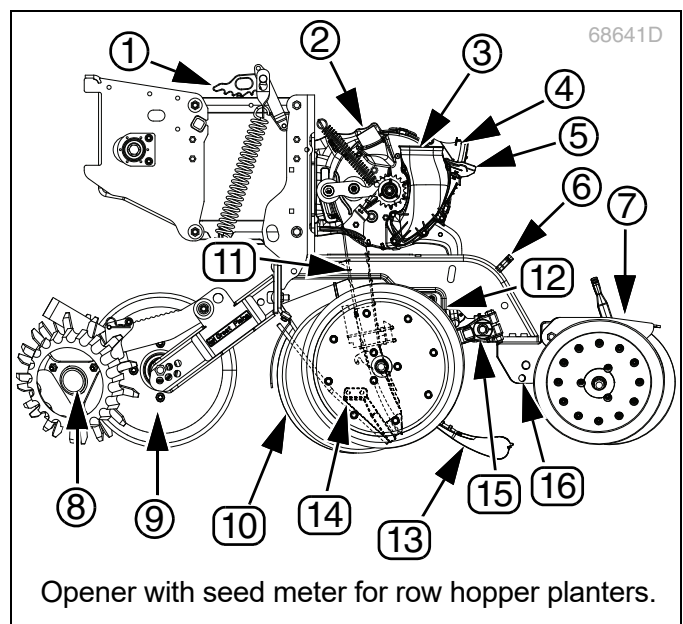
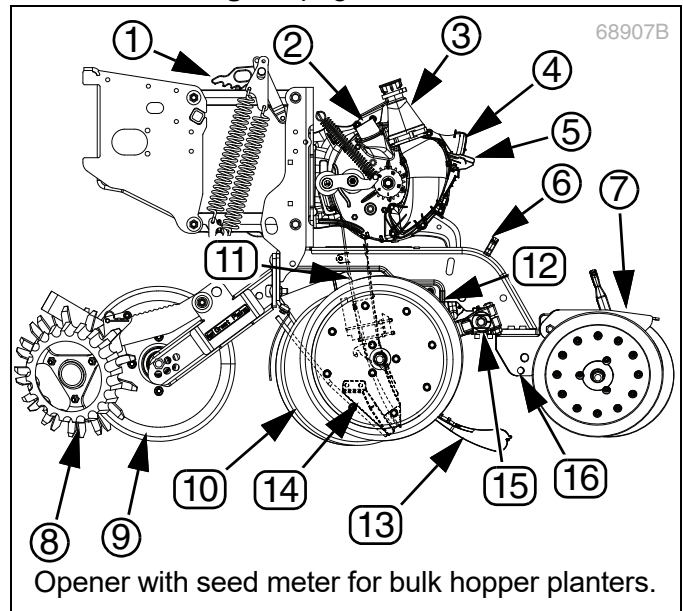

## ■ Row Unit Down Pressure

The ideal amount of down force causes the side depth wheels to compress any loose surface soil, but not press a trench into the subsoil.

To check down force, operate the planter for a short distance on typical ground, with or without seeding, and stop. Leave the planter lowered with row units in the ground.

At several row units, inspect the furrow created by the opener disks, but before the furrow closing by the press wheels (A).

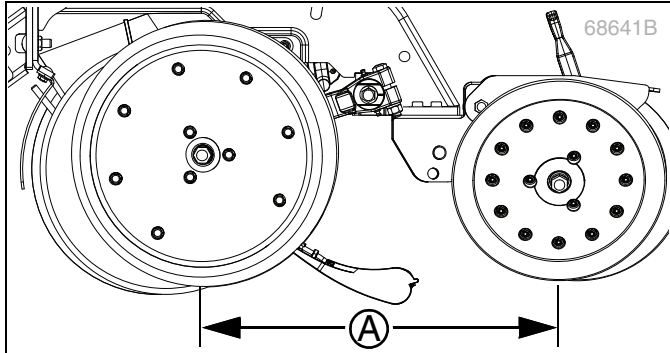

Be sure to inspect rows in and out of tire tracks.

- (1) If the side depth wheels are leaving no tracks, or light tracks, increase down force.
- (2) If the side depth wheels are compressing trash and loose soil, and leaving clear tracks at the top of the subsoil, down force is correct and needs no adjustment.
- (3) If the side depth wheels are creating a trench into the subsoil, down force is too high and needs to be reduced.

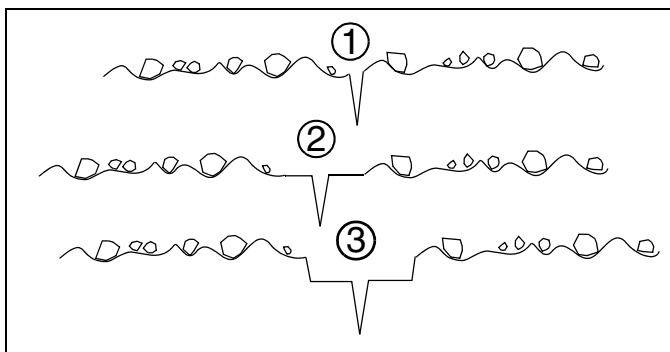

**Down-Pressure Adjustment**



**Population Risk**

Do not set all rows any higher than notch 4. Using settings above this on all rows will create uneven depth control and improper function.



**Tool Damage Risk**

Although this adjustment can be made with the planter lowered, the springs will be in tension and will require more effort. This extra force may damage tools.

Row unit springs provide the down pressure necessary for row unit disks to open a seed trench. Bulk hopper row units have dual springs, and row hopper row units have a single spring.

The springs allow the row units to float down into depressions and up over obstructions. The springs also provide down force on coulters when using optional row mounted coulters.

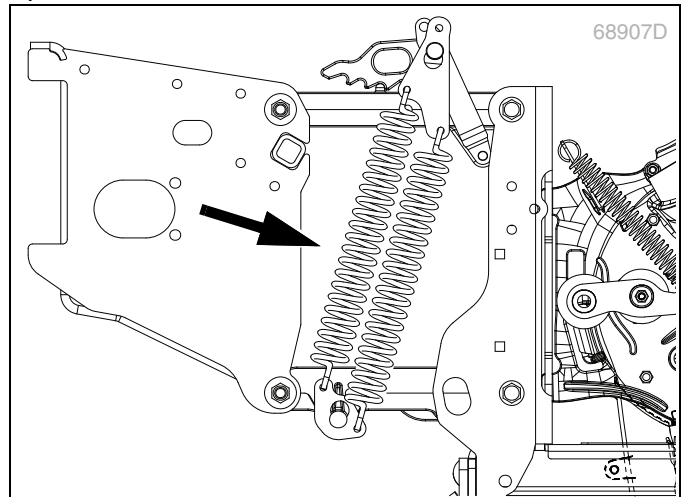

You can adjust down pressure individually for each row unit. This is useful for penetrating hard soil and planting in tire tracks. For best results, adjust tractor tires so the tires are not ahead of the planter rows.

Use only enough down pressure to cut the seed trench and maintain proper soil-firming over seed. Excessive row unit down force will lead to premature wear on row unit components. Excessive down force will also cause uneven seed depth.

**To adjust down pressure:**

1. Raise the planter and secure.
2. Use 1-1/8 inch (29 mm) open end wrench or the wrench stored at the left end of the planter. If using the supplied wrench, be sure the row unit is off the ground to fully relax the springs.
3. Position the wrench on the nut (2). Pull back and down.
4. Move the adjustment cam (3) to the new setting. Minimum setting (4) and maximum setting (5) are indicated by the position of the adjustment cam.

Each notch on the adjustment cam will increase the down pressure on the row unit springs. Use the table as a setting reference.

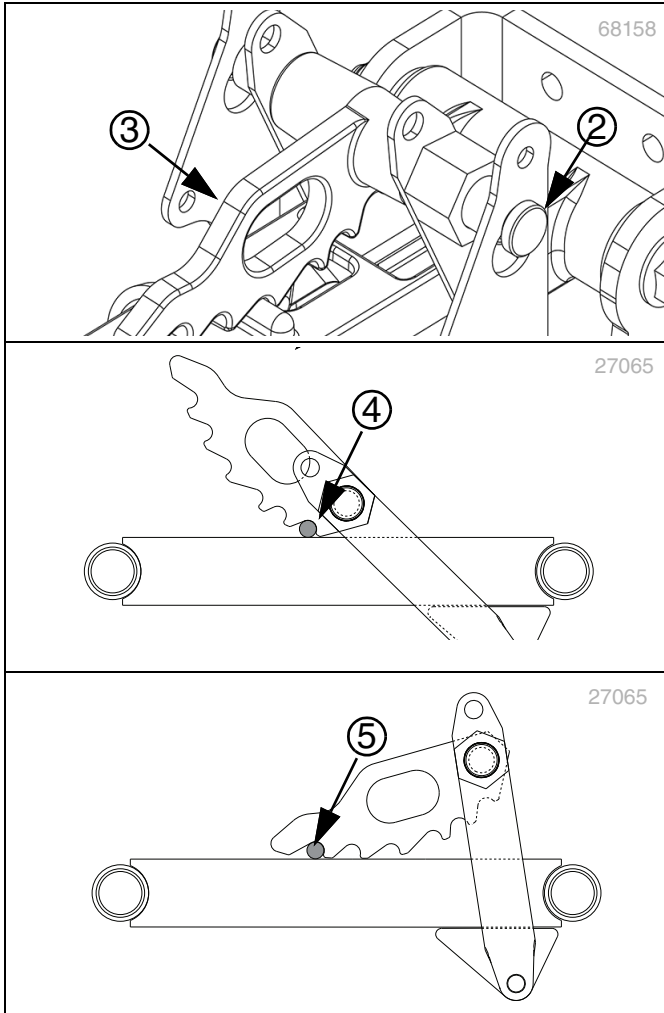

Individual rows may be set higher if running in tire tracks.

Cam Notch	Pounds		Kilograms	
	Single Spring	Dual Springs	Single Spring	Dual Springs
out of notch	Lock-up and maintenance			
1	255	320	115	145
2	265	355	120	160
3	285	385	135	175
4	315	435	145	200
5	345	485	155	220
6	375	535	170	245
tip of cam	Do not use			

## ■ Row Unit Opener Disks



### Sharp Object Hazard

Coulter and disk blades are sharp. To avoid serious injury, wear gloves when working in this area.



### Crushing Hazard

Verify machine is secure before working on it. A falling machine can result in serious injury or death.

The openers have three adjustments:

- Planting depth
- Openers disk-to-disk clearance
- Side depth wheel/opener disk clearance

### Planting Depth

The T-handle sets planting depth by limiting how high the side depth wheels ride relative to the opener disks. The position of the seed tube is fixed relative to the disks and is not adjusted.

#### To adjust seed depth:

- Move the T-handle forward (A) for shallower planting.
- Move the T-handle back (B) or deeper planting.

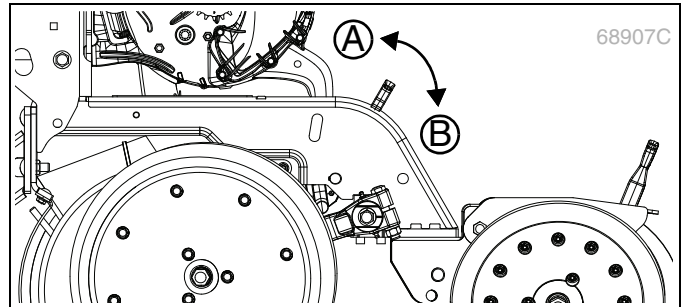

### Disk Contact Adjustment

Opener disk angle and stagger is not adjustable, but disk-to-disk spacing is, and may need attention as disks wear. Spacers will need to be reset when disks are replaced.

The ideal spacing causes the disks to be in contact for about 2.5 cm (1 in). If you insert two pieces of

paper between the disks, the paper should slide from touching to 3.8 cm (1-1/2 inch) from each other (A).

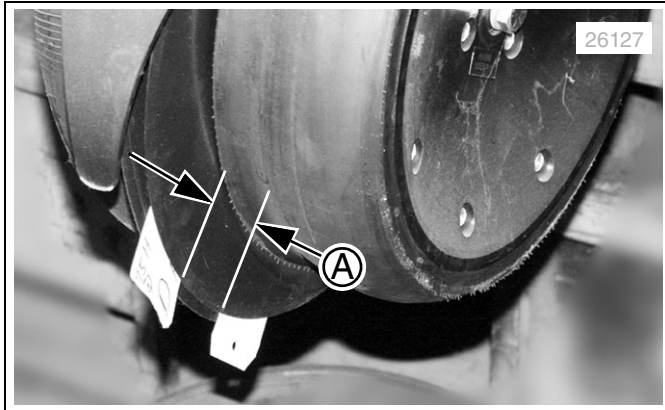

If the contact area is significantly larger or there is a large gap, adjust by moving one or more spacer washers.

**To move spacer washers:**

1. Raise the planter and install lift cylinder locks.
2. Remove the side depth wheels on the row unit needing adjustment.
3. Remove the bolt (1) retaining the opener disk (2) on one side.
4. Carefully remove the disk. Do not lose the hub components and spacer washers (3 and 4).
5. To reduce the spacing between disks, move one spacer washer from the inside (3) to the outside (4) of the disk.
6. Reassemble and check the disk contact.

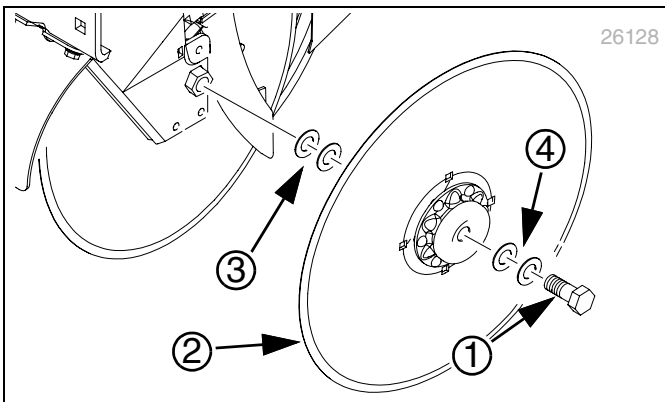

**Side Depth Wheel Adjustments**

For disk-to-wheel angle and clearance, the side depth wheel (1) should just be touching the opener disk (2) when the wheel is raised to planting depth.

The goal is to have both disks and wheels turn freely, but keep soil and trash from getting between them.

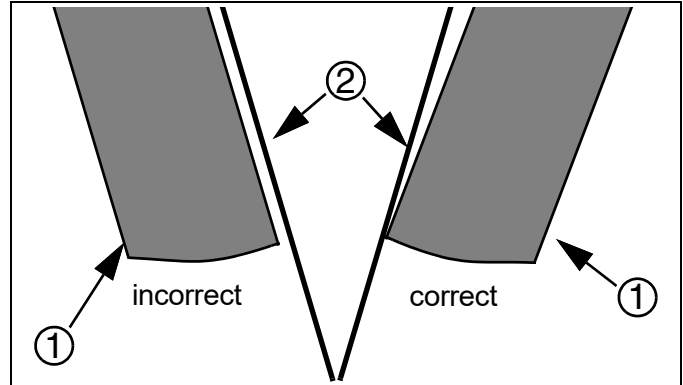

The side depth wheels have two adjustments. Changing one requires at least checking the other. The two adjustments are:

- angle of side depth wheel
- distance between side depth wheels and disks.

In addition to changing the disk angle due to changing depth or new field conditions, the two settings may need attention over time as the disk and wheels wear from normal use. This adjustment will also need to be made if any opener components are replaced.

For 2 inch (5 cm) planting depth, adjust the side depth wheel angle so the wheels contact the row unit disks at the bottom of the wheel and the gap is 3/8 to 5/8 inch (9.5 to 16 mm) at the top. Check with row units in the soil so wheels are held up.

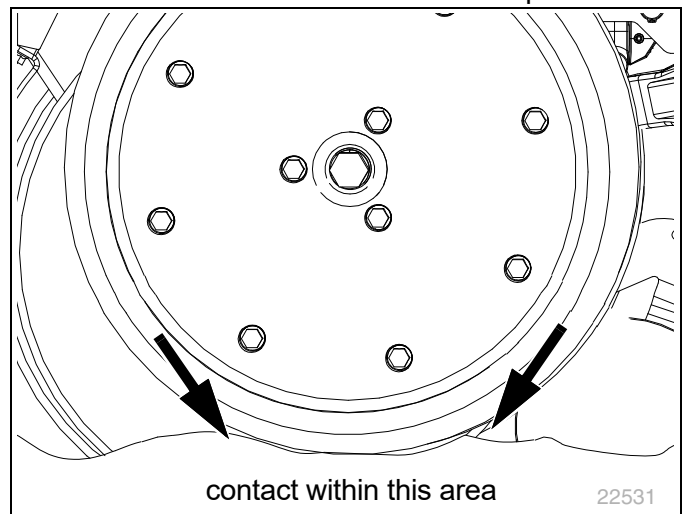

At the same time, keep side depth wheels close to opener disks so openers do not plug with soil or trash. Wheels should be out far enough so disks and wheels turn freely.

**To adjust the side depth wheels:**

1. Raise the planter slightly, removing the weight from the side depth wheels.
2. Loosen the bolt (1).

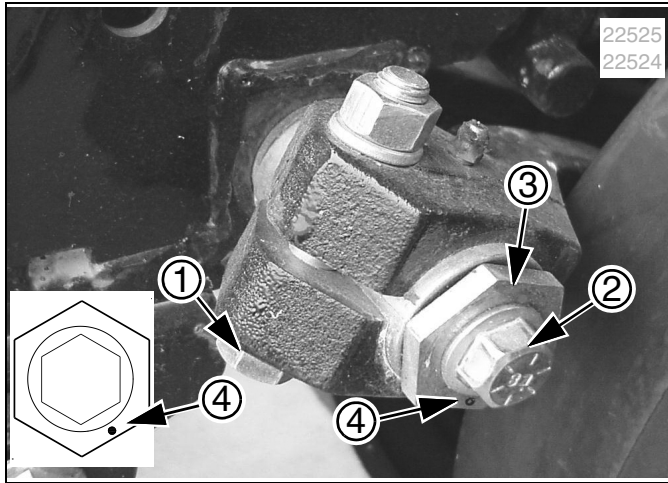

3. Move the wheel and arm out on the O-ring bushing.
4. Loosen the pivot bolt (2).
5. Turn the hex adjuster (3) so the indicator notch (4) is at 5 o'clock to 7 o'clock. Use this as the starting point for adjustment.
6. Move the wheel arm in so the side depth wheel contacts the row unit disk.
7. Tighten the bolt (1) to clamp the arm around the bushing and shank.
8. Check wheel-to-disk contact at 2 inch (5 cm) planting depth. Lift wheel 2 inch (5 cm), check the contact, and release. When let go, the wheel should fall freely.
  - If the wheel does not contact the disk at the bottom to the area where the disk leaves contact with the soil, move the hex adjuster until the wheel is angled for proper contact with the disk.
  - If the wheel does not fall freely, loosen the bolt (1) and slide the wheel arm out just until the wheel and arm move freely. Tighten the bolt as follows:  
 Grade 5 bolt - 76 ft lb (105 Nm)  
 Grade 8 bolt - 110 ft lb (150 Nm)
9. Keep turning the hex adjuster and moving the wheel arm until the wheel is adjusted properly.
10. When properly adjusted, tighten the pivot bolt (2) to 110 ft lb (150 Nm).

**■ Depth Wheel Scrapers (Option)**

Side depth wheel scrapers may be useful in moist or sticky soils that tend to accumulate on side depth wheels reducing the intended planting depth.

**To adjust depth wheel scrapers:**

1. Loosen the nut (1).

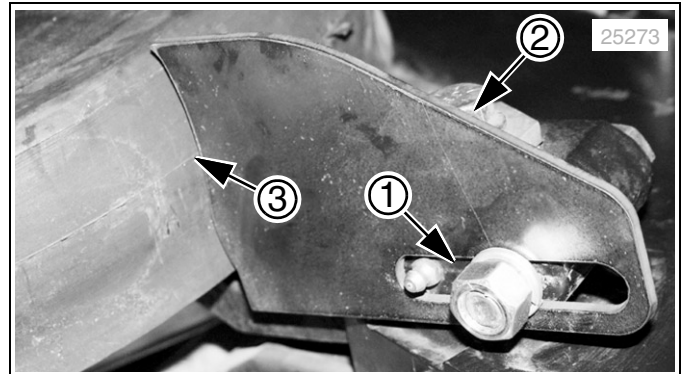

2. Slide the depth wheel scraper (2) toward the depth wheel until the scraper touches the tire.
3. Slide the scraper away from the wheel leaving a 1/8 inch (3 mm) gap (3).
4. Rotate the scraper left and right around the bolt, making sure it cannot touch the tire if bumped in the field. If it can touch the tire, back the scraper away from the wheel until it cannot.
5. Center the scraper angle on the bolt until the gap (3) is constant.
6. Tighten the nut (1).

**■ Press Wheel Adjustments**



**Crushing Hazard**

*Ensure machine is secure before working on it. A falling machine can result in severe injury or death.*

Press wheels are attached to each row unit body. The press wheels close the seed trench and press soil over the seed.

To provide consistent seed firming, the press wheels are free to move downward from the normal operating position. This system maintains closing/pressing action even if the row unit arm is lifted when the disks encounter obstructions.

There are three adjustments on the press wheel assembly:

- Down pressure - an adjustable spring in the press wheel mechanism creates the down pressure needed to close the seed trench. The amount of force needed will vary with field conditions.

- Wheel stagger - factory setting is staggered for the best residue flow.
- Centering - press wheels should be centered over the seed trench.

If the press wheel adjustments do not provide satisfactory furrow closing, your conditions may require alternate press wheels. A variety of press wheel assemblies are available. See your Great Plains dealer for information.

**Down Pressure**

To adjust the down pressure:

1. Lower planter into field position.
  2. Move the adjustment handle (1).
- For less down pressure, move the handle forward (A) toward the planter.
  - For more down pressure, move the handle back (B) away from the planter.

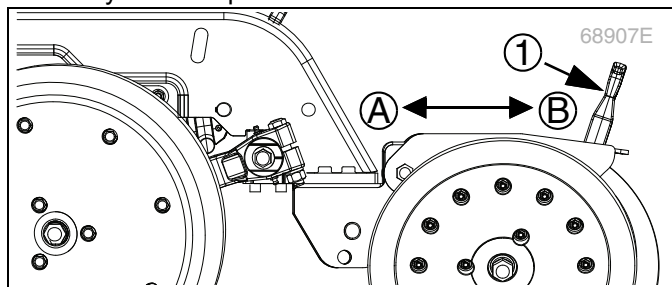

Increased press wheel spring force may require increased row unit down force to maintain depth.

**Press Wheel Stagger**

To change the press wheel stagger:

1. Raise the planter.
2. Remove the bolt (1), spacers (2 and 3), lock washer (4), and nut (5).

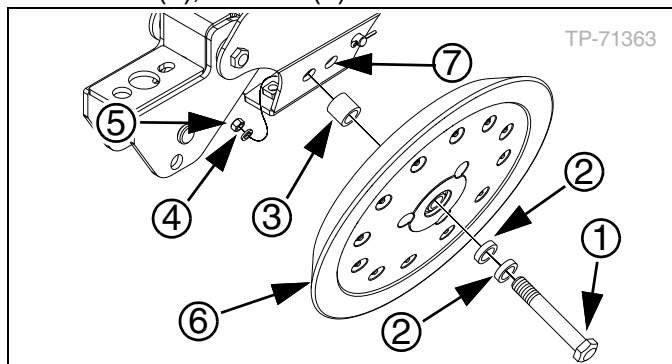

3. Reinstall the spacers, press wheel (6), and hardware to the other hole location (7).

**Press Wheel Centering**

If one press wheel is running in the seed trench, or the press wheels are not centered over the trench, the angle (1) of the press wheel assembly can be adjusted.

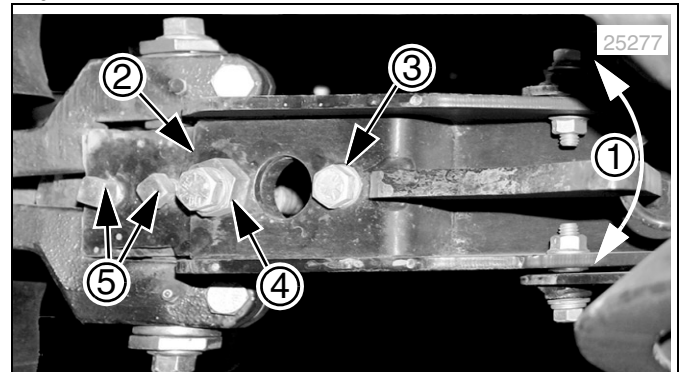

To adjust the angle of the press wheel assembly:

1. Determine how far and in which direction the press wheel assembly needs to move to center the wheels.
2. Raise the planter.
3. Loosen the 1/2 inch bolts (2 and 3). Do not loosen the two front bolts (5).
4. Turn the hex head cam (4) under the bolt (2), and move the required amount.
5. Tighten both bolts.

**Unit Mount Row Cleaners (Option)**



**Sharp Object Hazard**

Row cleaner tines, casting edges, and coulter disks are sharp. To avoid serious injury, wear gloves when working in this area.

Martin row cleaners are unit-mounted:

- Unit-mount row cleaner (UMRC) - stand-alone
- Unit-mount coulter row cleaner (UMC-RC) - on a coulter bracket, with or without a coulter disk present.

Refer to the manual supplied with the row cleaners for further information on use, adjustment, and maintenance of row cleaners.

The row cleaners have two adjustments:

- Wheel placement for more or less aggressive cleaning
- Wheel height adjusted by a stop. The cleaner arms float. The stop only sets the lowest position.

The row cleaners need to be adjusted for conditions, crop changes, and as coulters and openers wear. Ideally, cleaners contact only the trash, and do not disturb the soil. If allowed to dig, row cleaners can reduce seed coverage.

Tine tips should be at ground level for the suggested initial height.

**To adjust the row cleaner:**

1. Raise the planter.
2. Determine the height adjustment required. Measure from the lowest tine to the ground.
3. Support most or all of the weight of the arm to prevent injury and ease the adjustment.
4. Adjust the arm:

**UMRC (S/N E1024B-)** - Remove the bent pin (1). Support the arm at the desired height. Slide the adjustment tube (2) until the cross-tube (3) contacts the arm at the target height. Insert the bent pin in whichever hole pair is most in alignment.

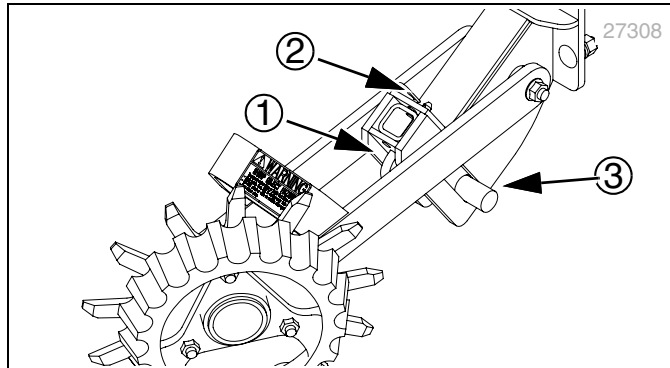

**UMRC (S/N E1025B+)** - Raise arm (1), support with large screwdriver through cross holes in mount. Remove the tee plate clevis pin (2) and adjust tee plate (3) to the desired stop height. Re-install tee plate, clevis pin, and cotter. Raise arm slightly, remove screwdriver, and set arm onto the tee plate.

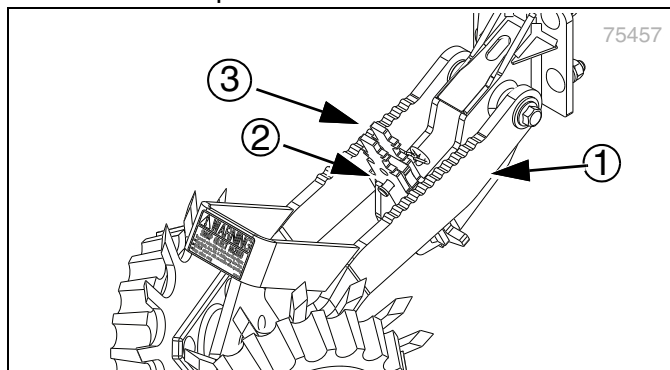

**UMC-RC (S/N E1024B-)** - Loosen the bolts (4). Slide the down-stop (5) on the arm (6) back toward the pivot for shallower cleaning, or forward toward the tines for deeper cleaning.

Tighten the bolts. Each possible hole pairing adjusts the tine height by about 3/4 inches (19 mm). Also check bolt tightness before each planting session, to avoid down-stop slippage.

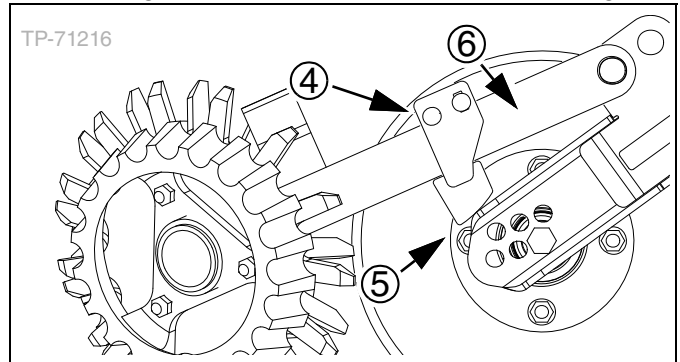

**UMC-RC (S/N E1025B+)** - Remove pin(4) from adjuster stop(5). Raise row cleaner arm(6) to slightly higher than desired operating height. Tilt the adjuster stop slightly and move it up until it contacts with the coulters. Re-insert clevis pin and cotter. Relax arm onto adjuster stop.

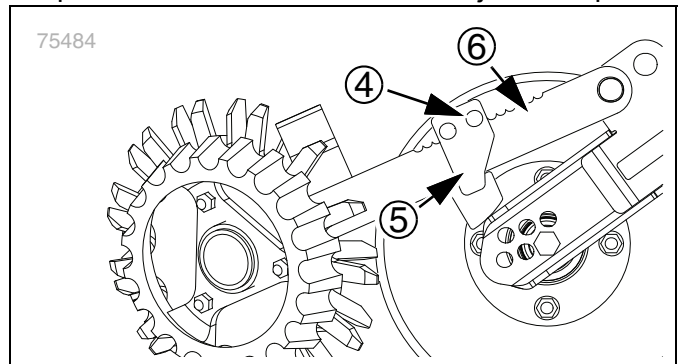

5. Check the new height measurement.

**■ Unit Mount Coulters (Option)**



**Sharp Object Hazard**

Row cleaner tines, casting edges, and coulters are sharp. To avoid serious injury, wear gloves when working in this area.



**Crushing Hazard**

Ensure machine is secure before working on the machine. A falling machine can cause severe injury or death.

The best operating depth for coulters is 1/4 inch (6mm) above the opener depth. The coulters may have originally been set to this depth, but coulters and opener disks wear with time, and may need adjusting.

Adjust the coulters depth by mounting the coulters disk in one of the six mounting holes on the coulters bracket.

**To adjust coultter depth:**

1. Raise and secure the planter. Row units may be fully lowered or locked up. Do not attempt to move the blade when the current or new position causes it to contact the ground during adjustment.
2. Remove row cleaners, if installed, to reduce risk of injury.
3. Determine the current opener and coultter depths.

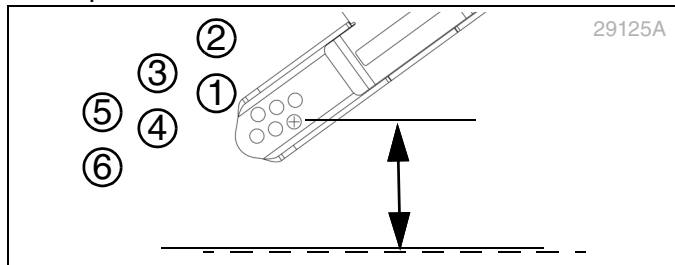

4. Determine which new hole will position the coultter closer to the 1/4 inch (6mm) depth by the using the table below.

Hole Number	Depth of coultter disk relative to opener disk
1	0
2	1 inch (25 mm) above
3	5/8 inch (16 mm) above
4	3/8 inch (9.5 mm) below
5	1/4 inch (6 mm) above
6	3/4 inch (19 mm) below

5. Remove the 5/8 x 4 inch bolt, lock washer, and nut (7).

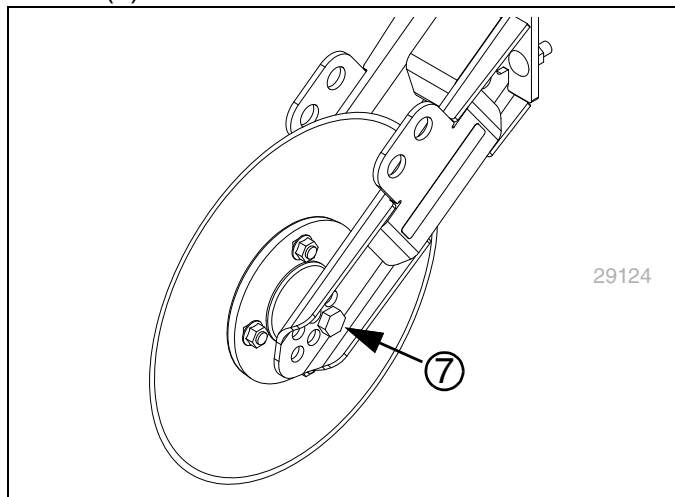

6. Move the coultter disk to the new position.

7. Install the bolt and fasten the lock washer and nut.
8. Readjust row cleaners, if installed.

If a worn coultter cannot be adjusted to the proper operation depth, replace the coultter disk.

**Coultter Row Alignment**

For unit-mounted coultters, the ideal alignment is for the disk to open a furrow directly ahead of the opener disks.

**To check alignment:**

1. Sight along the coultter disk centerline (1), the gap between the opener disks, and the centerline between the press wheels.

If they are out of alignment, either the coultter, press wheels, or both may need to be adjusted.

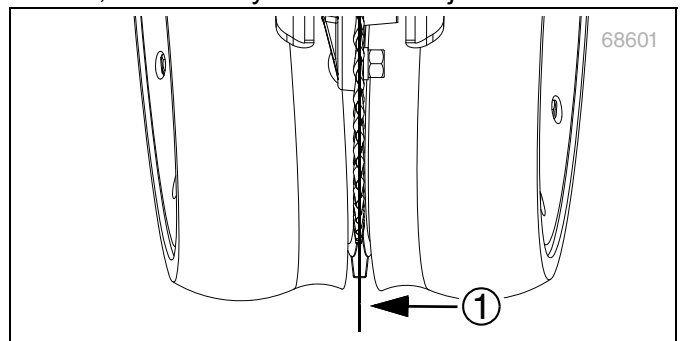

Operate the planter on test ground, no seed required, and verify that the opener disks are in the groove opened by the coultter, and that the press wheels are centered over the furrow. See **“Press Wheel Adjustments”** on page 56.

**To adjust coultter alignment:**

1. Loosen the four bolts (2) that attach the coultter bracket to the row unit. The holes on the row unit are slotted for adjustment.

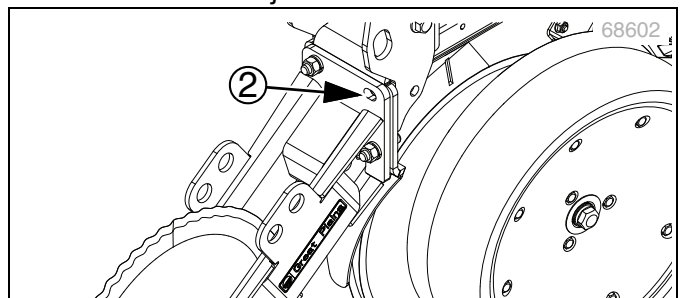

2. Keep the coultter disk vertical while adjusting.



If the disk cannot be aligned, check that the spindle is using the same hole location on each side of the bracket.

3. Tighten four bolts (2) once preferred alignment has been achieved.

### ■ Seed Firmer (Option)



#### **Sharp Object Hazard**

*Disks are sharp. To avoid serious injury, wear gloves when working in this area.*

### Keeton® Seed Firmer

A Keeton® seed firmer has a polymer shape that slides down the seed trench. It traps the seeds as they exit the seed tube and firms them into the bottom of the seed trench.

The Keeton Seed Firmer is provided with a preset tension which is recommended for the first year of planting. The tension screw (1) can be tightened after the first year, according to your needs. The seed firmers should provide just enough tension to push seeds to the bottom of the trench.

Measure the distance from the ground to the head of the tension screw. This distance should be 4 to 4 1/2 inch (10.2 to 11.4 cm).

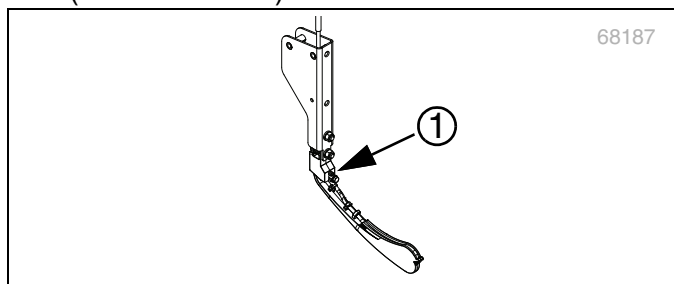

If adjustment is necessary, loosen the bolts in the mounting bracket and select different holes until the proper measurement is reached.

### ■ Swath Command™ (Option)

The optional Swath Command™ system replaces the standard 2-section operator-controlled clutches with clutches under console control. There are 8 sections of clutches for 16-row planters, and 6 sections of clutches for 12-row planters.

The Swath Command system automatically turns off rows when the row unit enters a non-planting area, as defined by pre-loaded information, or if the row enters an area already logged as planted during previous passes.

Refer to the Swath Command manual for setup and operation of the system.

### ■ Liquid Fertilizer (Option)



#### **Agricultural Chemical Hazard**

*Some chemicals will cause serious burns, lung damage, and death. Avoid contact with skin or eyes. Avoid prolonged breathing of chemical fumes. Wear respirator and other protective equipment as required by chemical manufacturer. Seek medical assistance immediately if accident occurs. Know what to do in case of an accident.*



#### **Plugging Risk**

*Load chemicals just before using. If fertilizer remains in the tanks for extended periods, settling of material and system plugging will occur.*



#### **Pump Damage Risk**

*Always disable the pump drive when not in use. Do not operate the pump when not applying material.*

The fertilizer rate is independent of the seed rate. Fertilizer rate is set by a pump dial and a driving sprocket on a ground drive planter, or console controlled for hydraulic and IRC planters.

Great Plains recommends checking with your local agronomist as soil conditions vary. Soil conditions in your area may need less or more amounts of fertilizer than represented in the charts in this manual. In any case, do not exceed 12 gal/acre (112 liter/ha) in furrow.

### Loading Materials

To load material:

1. Connect the nurse tank hose to the quick-fill coupler (1) at the rear of the planter.

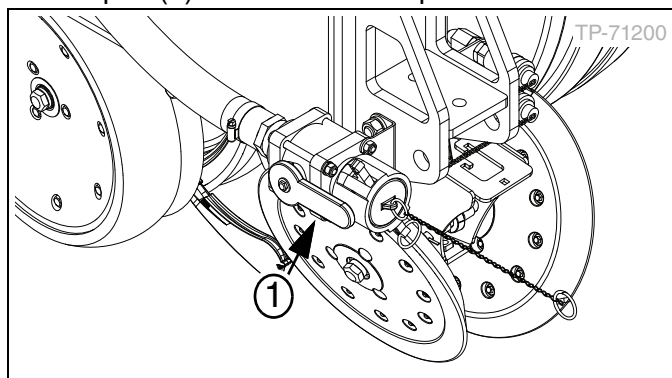

2. Lock the hose in place with cam lock levers.
3. Close the valve going to the inline filter located just before the pump.



#### Contamination Risk

Always close the valve at the inline filter when filling or storing any liquid in the tanks. Failure to do so may allow material to run out of the manifold (boom) outlets causing contamination from spillage.

4. Open the valve at the quick-fill coupler.
5. Fill the tank, then close the valve at the quick-fill coupler.
6. Disconnect the nurse tank hose.

### Orifice Plates

The orifice plate needs to be small enough to create at least 15 psi of pressure in the manifold, but large enough to prevent the manifold pressure from exceeding 85 psi.

The minimum pressure is required to even out the flow of fertilizer between rows. To reduce orifice plugging and pump wear, use the largest orifice practical for your fertilizer application rate.

The best pressure range to maintain is 15 to 40 psi to ensure optimum distribution while minimizing leakage.



Orifice size does not control rate. It is only used to create 15 to 65 psi back pressure for even flow between rows. Set application rate in gal/acre using the pump drive chart.

Orifice Size	Part Number	Part Diameter	Port Area
20	832-052C	0.020 inch	0.20 mm <sup>2</sup>

Orifice Size	Part Number	Part Diameter	Port Area
28*	832-056C	0.028 inch	0.40 mm <sup>2</sup>
34*	832-053C	0.034 inch	0.59 mm <sup>2</sup>
48*	832-054C	0.048 inch	1.17 mm <sup>2</sup>
59	832-057C	0.059 inch	1.76 mm <sup>2</sup>
80	832-055C	0.080 inch	3.24 mm <sup>2</sup>
98	832-059C	0.098 inch	4.87 mm <sup>2</sup>

\* Standard sizes in many fertilizer bundles. Check your accessories before ordering.

### Rate Ranges vs. Orifice Size

Orifice Size	Nozzle Spacing in US Customary Units*	
	30 in Row Spacing	70 cm Row Spacing
20	1.1-1.8	1.2-2
28	2.1-3.4	2.3-3.7
34	3.2-5.2	3.4-5.6
48	6.1-10	6.7-11
59	9.3-15	10-17
80	17-28	19-30
98	27-44	29-44

\* Recommended Rate Range in gallon per acre. Pressure is 15-40 psi. Values based on: 5 mph and 10.7 lbs/gallon Fertilizer solution density.

Orifice Size	Nozzle Spacing in Metric Units*	
	30 in Row Spacing	70 cm Row Spacing
20	1.1-1.8	1.2-2
28	2.1-3.4	2.3-3.7
34	3.2-5.2	3.4-5.6
48	6.1-10	6.7-11
59	9.3-15	10-17
80	17-28	19-30
98	27-44	29-44

\* Recommended Rate Range in liters per hectare. Pressure is 103-276 kPa. Values based on: 8.0 kph and 1.28 kg/liter Fertilizer solution density.

### Orifice Plate Installation

To install the orifice plates:

1. Insert the orifice plate (1) inside the gasket (2) supplied with the nozzle.

2. Insert the gasket and orifice plate with the number side facing out the nozzle outlet.

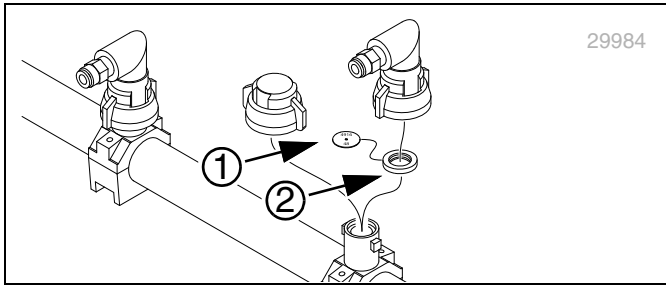

**Strainer**

A strainer is supplied with the fertilizer pump. It is plumbed before the pump. The standard 80 mesh screen (3) should be suitable for most applications. Other screen sizes are available from Banjo Corporation.

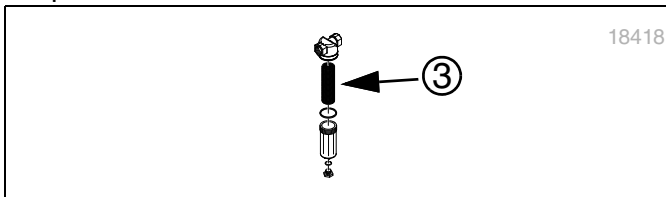

If changing screen sizes, keep in mind the following:

- A smaller mesh (100) will keep very small manifold orifice plates from plugging so often. However, the screen will have to be cleaned more often.
- A larger mesh (50 or 30) will pass more material, but should only be considered when using large manifold orifice plates.
- A plugged or partially plugged screen will starve the pump, resulting in a reduced application rate.
- Mesh sizes from smallest to largest: 100, 80, 50, 30.

**Relief Valve**

A relief valve is plumbed after the pump outlet to protect the manifold and pump from excessive pressure. Any product that dumps over the relief valve will discharge from the dump line.

**To set the relief valve on the fertilizer pump:**

1. Unlock the plastic jam nut (4) from the relief valve knob (5).

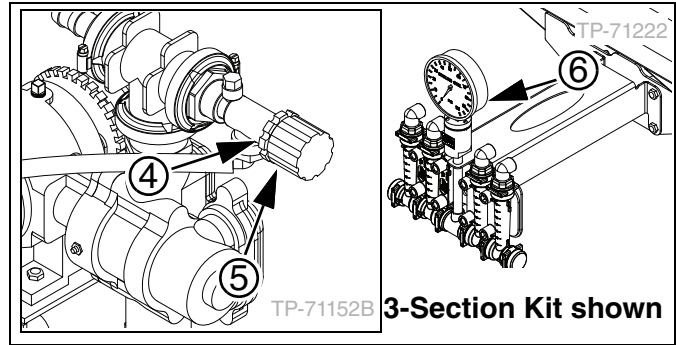

2. Turn the knob counterclockwise two turns. Start at this setting.
3. Observe the manifold gauge (6) at the front of the fertilizer tank. Watch for relief valve discharge while operating in the field.
4. If the valve is dumping product and the gauge reads under 65 psi, stop the tractor and turn the knob clockwise 1/4 turn. Continue operating at normal field speed. Repeat this step as needed until no product is discharged from the relief valve.
5. If the pressure gauge reads above 65 psi, change to a larger orifice. Go to step and repeat the steps.

**Setting Fertilizer Rate**

This is only an overview of how to set the fertilizer rates. Refer to the Material Rate manual. Refer to the John Blue manual for more fertilizer pump details. Refer to your console manual for more console operation details.

Fertilizer rate is controlled by pump rate. Consistent delivery across the planter is controlled by orifice size at the row unit drop-line points.

Consistent system operation also requires a correctly adjusted relief valve and a well maintained strainer ahead of the pump. See “**Liquid Fertilizer Strainer**” on page 70.

Great Plains recommends checking with your local agronomist as soil conditions can vary. Conditions in your area may need less or more amounts of fertilizer.

**Fertilizer Ground Drive**

The ground drive liquid fertilizer option uses a positive displacement pump. For pump operation and pump maintenance, refer to the pump manual supplied with the ground drive pump option package.

For fertilizer rate settings, see the Material Rate manual.

The pump is driven by a ground contact wheel (1). The fertilizer rate is independent of seed rate.

Coarse fertilizer rate is set by a sprocket (2) on the ground drive. Fine rate is set by a dial (3) on the pump. For more information, see the Material Rate manual.

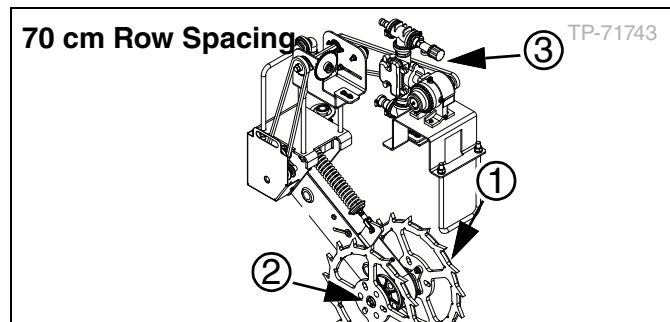
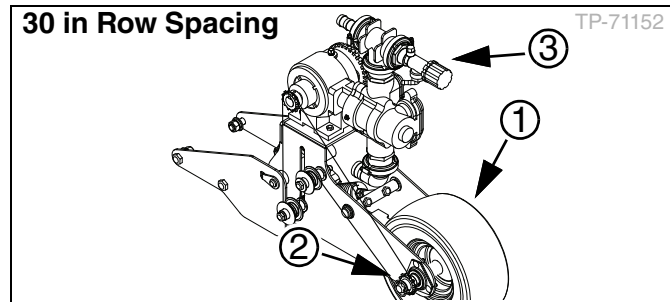

**Fertilizer Hydraulic Drive**

The fertilizer hydraulic drive uses a fixed displacement pump driven by a hydraulic motor under console control. This section offers basic instructions to set the desired target material rate, see your console operator manual for more information.

**To set the desired target material rate:**

1. With your in-cab console, tap the Materials softkey from the Home screen.



2. Tap a Flow Control Material softkey (shown as MATRL 15 for illustrative purposes only).

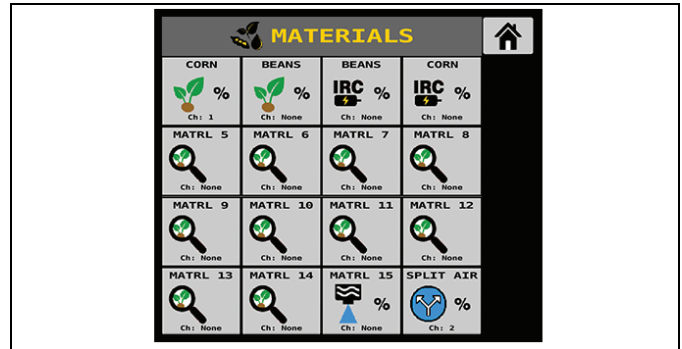

3. Tap Edit softkey.
4. Set these parameters:

**Type** - Select Liquid Control for liquid fertilizer application.

**Units** - Gal/ac with gal/min will auto-populate with the selection of Liquid Control for material type.

**Preset Method** - Selecting Enabled will allow 10 user defined presets target rates to be entered as adjustments. Selecting Disabled will allow incremental +/- percentage adjustments from the Work Screen during application.

**Target Rate** - Select your desired target rate. Refer to the Material Rate manual for more information.

**Maximum Rate** - Establishes the maximum application rate in gal/ac that the control will allow.

**Minimum Rate** - Establishes the minimum application rate in gal/ac that the control will allow.

**Inc/Dec%** - Sets the incremental increase/decrease percentage of change that will be applied each time to the desired target rate during application when the increment/decrement is tapped from the Work Screen.

**Low Flow Limit** - Sets the lowest gallon per minute flow rate which the control channel will operate.

**High Flow Limit** - Sets the highest gallon per minute flow rate which the control channel will operate.

**Material Level Alarm** - Sets the level to trigger an alarm alerting of low liquid levels. The entered value is an estimate in gallons.

## AccuShot Fertilizer System (Option)

The optional AccuShot Fertilizer System allows precision liquid fertilizer application during planting. For system operation, refer to the AccuShot manual supplied with the AccuShot option package.

## Fertilizer Section Control System (Option)

The optional VisaGage II System allows for section control, refer to the VisaGage II manual supplied with the VisaGage II option package.

## ■ Parking



### Roll-Away Hazard

*There is not enough weight on parking stands to anchor planter on a slope. Do not unhitch planter while on a steep slope. Always block tires when unhitching from tractor.*

Follow these steps when parking the planter for periods of less than 36 hours. For longer periods, see “**Storage**” on page 72.

1. Position the planter on firm, level ground.
2. If installed, fold markers.
3. If equipped with fertilizer, flush the system and protect the pump against corrosion.
4. Fold the planter.
5. To prevent rolling, block the tires securely.
6. If the ground is soft, place a board or plate under each stand to increase contact area.
7. Remove the pins (1) and position the parking stands in the parking position. Insert the pins.

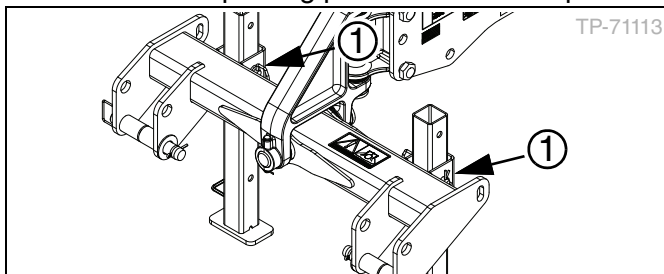

8. Lower the tractor 3-point until the planter is resting on the parking stands.
9. Set all implement hydraulic circuits to float to relieve pressure in the lines.
10. Shut down the hydraulics and unplug the hydraulic lines from the tractor. Do not allow hose ends to rest on the ground. Protect ends from contamination.
11. Unplug the light harness and console harness. Protect the connections with any plugs or caps provided.

12. Unhitch the planter from the tractor.

## ■ Transport



### Loss of Control Hazard

*Never tow an implement that weighs more than 1.5 times the weight of the tractor. Using an inadequate tow vehicle can result in loss of control, serious injury, and death.*



### Excessive Speed Hazard

*To prevent serious injury or death, do not exceed 20 mph (32 kph) maximum transport speed. Loss of vehicle control and/or machine damage can result.*



### Planter Damage Risk

*When the planter has been configured with the weight transfer system, if using any other equipment for transport other than a suitable tractor, install shipping links to prevent planter damage during transport.*

The planter can be transported with a full material load, but the added weight increases stopping distance and decreases maneuverability. Follow these instructions when transporting the planter over roadways. If the planter will be transported or shipped on a trailer, see “**Trailer Shipping**” on page 126.

- Transport only with markers folded.
- Verify the planter is securely hitched to a sufficient tractor.
- Unload seed hoppers before transporting if possible.
- Transport the planter only in the folded position. Ensure all four lift cylinder locks are in place and not in storage location.
- Transport the planter only if the wing hooks are engaged on the tongue stop.
- If any seed is in the hoppers or delivery hoses, close the seed inlet gates at the seed meters.
- Check that tires are properly inflated.
- Plan the route. Avoid steep hills.
- Verify that the lights operate correctly. Always have lights on for highway transporting.
- Comply with all national, regional, and local safety laws when traveling on public roads.
- Remember that the planter is wider than the tractor. Allow safe clearance.
- Transport slowly over uneven or rough terrain.

# Maintenance

Proper servicing and maintenance is the key to long implement life. With careful inspection, you can avoid costly maintenance, downtime, and repair.

Always install cylinder locks, relieve hydraulic pressure, engage the parking brake, turn off the tractor, remove the tractor key, and block tires and frame before making any adjustments or performing any maintenance.



### Crushing Hazard

A falling implement can cause severe injury or death by crushing. Always have cylinder locks in place and the frame blocked up when working on the implement.



### High Pressure Fluid Hazard

Escaping fluid under pressure can have sufficient pressure to penetrate the skin. Check all hydraulic lines and fittings before applying pressure. Use paper or cardboard, not body parts, and wear heavy gloves to check for suspected leaks. If injured, seek immediate medical attention from a physician familiar with this type of injury.



### Flailing Hazard

Marker hydraulics are active whenever the fold hydraulics are not in use. It is important to set the tractor fold/marker hydraulic circuit lever to “Float” or “Neutral” to prevent unintended marker operations. Unexpected marker operation and flailing equipment can seriously injure including death.



### Component Damage Risk

When cleaning the planter, to avoid damage to IRC components, do not powerwash on or around these electrical components.

## ■ Maintenance Schedule

Maintenance Point	Type of Maintenance	Frequency
Wheel hardware (page 118)	Check torque	Daily
Tire pressure (page 118)	Check pressure	Daily
Wheel bearings (page 71)	Clean and pack	Seasonally
Marker disk hub bearings (page 71)	Clean and pack	Seasonally
Chains (page 68)	Inspect and lubricate	Periodically
Seed meter disks (page 68)	Inspect for damage or wear	Each time seed disks are removed
Seed meter brushes (page 66)	Clean and inspect for wear	Each time seed disks are removed
Hydraulic drive filter (page 61)	Replace element	When indicated by pop-out indicator
Liquid filter strainer (page 70)	Clean	Several times per season, end of season

## ■ Regular Maintenance

- ☑ After using the planter for several hours, check all bolts to be sure they are tight. See “**Torque Value Chart**” on page 118.
- ☑ Remove excess slack from chains. Clean and use chain lube on all roller chains as needed. See “**Chain Slack**” on page 68.
- ☑ Maintain proper air pressure in the tires. See “**Tire Information**” on page 118.
- ☑ Keep disk scrapers properly adjusted. See “**Depth Wheel Scrapers (Option)**” on page 51.
- ☑ Clean the planter on a regular basis.
- ☑ Lubricate areas listed under “<Bold>Lubrication” beginning on page 71.
- ☑ Replace any worn, damaged, or illegible safety decals by obtaining new decals from your Great Plains dealer. See “**Safety Decals**” on page 5.

## ■ Hydraulic System



### **High Pressure Fluid Hazard**

Do not attempt to make hydraulic system repairs. Great Plains strongly recommends that all hydraulic system repairs to be completed by a trained professional who is knowledgeable about how to safely complete hydraulic system work. You should only maintain or adjust your hydraulic system as described within this manual. Compromising a closed hydraulic system can cause serious injury or death.

The hydraulic system is a closed system and will come from the factory fully charged and bled.

Your planter is equipped with lift and fold hydraulic cylinders designed with rephasing ports which will allow for the release of air from the hydraulic system. See “**Unfolding**” on page 23.

### **Hydraulic System Inspection**

Routine hydraulic maintenance will require inspection of hydraulic lines, valves, fittings, and cylinders for any signs of damaged or worn parts, and the presence of hydraulic fluid. If you discover or suspect a leak, or damaged or worn parts, contact your Great Plains dealer for service on your hydraulic system by a trained professional.

## ■ Hydraulic Drive



### **High Pressure Fluid Hazard**

Escaping fluid under pressure can have sufficient pressure to penetrate the skin. Check all hydraulic lines and fittings before applying pressure. Use paper or cardboard, not body parts, and wear heavy gloves to check for suspected leaks. If injured, seek immediate medical attention from a physician familiar with this type of injury.

### **Hydraulic Drive Filter**

Contamination is the most common cause of performance problems and premature wear in a hydraulic drive system. Before each connection is made, properly clean quick-connect couplers before you attach the hydraulic hoses to the tractor.

All hydraulic fluid is filtered through the high pressure filter (1) which contains a replaceable filter element (2), and it provides protection to the hydraulic components of the drive if properly maintained.

The high pressure filter (1) is equipped with a pop-out indicator (5) when the replaceable element (2) is clogged, and should be changed immediately.

Normal service life of the replaceable element will vary based on the precautions taken to minimize contamination at the couplers and route service of the tractor filtration.

To replace the element:

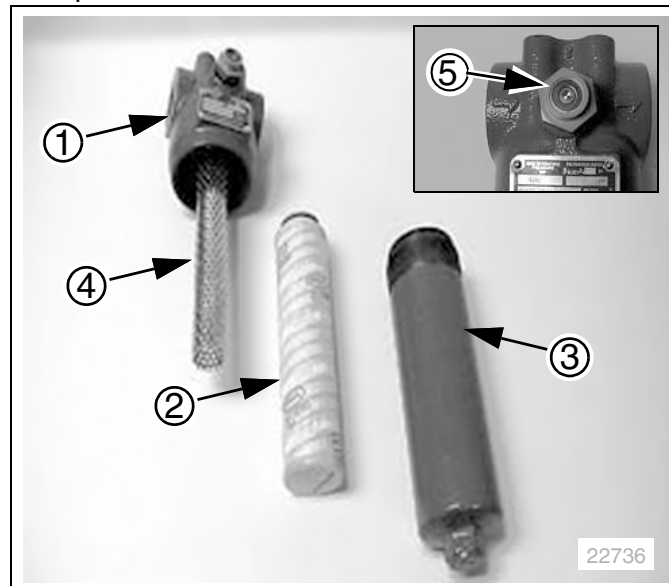

1. Unscrew the lower filter canister (3) from the filter (1); catching and disposing of the used fluid.
2. Remove and discard the filter element (2).
3. Install a new filter element (2).
4. Clean the canister threads (4) and lube the O-ring with hydraulic fluid, then reinstall.
5. Reset the pop-out indicator (5) if necessary.

Keep a filter element (2) on hand. Great Plains recommends changing the filter element at least seasonally, or when alerted by the pop-out indicator.

## ■ Markers

### **Marker Shear Bolt**



#### **Equipment Damage Risk**

Replacing the shear bolt with a higher grade bolt can result in marker damage.



Do not replace the shear bolt with a lower grade bolt, or smaller bolt, or you may experience nuisance shears.

The marker arm is attached to the marker body with a 7/16 - 14 x 2 Grade 5 shear bolt. If the shear bolt

breaks, replace with Great Plains part number 802-589C or equivalent.

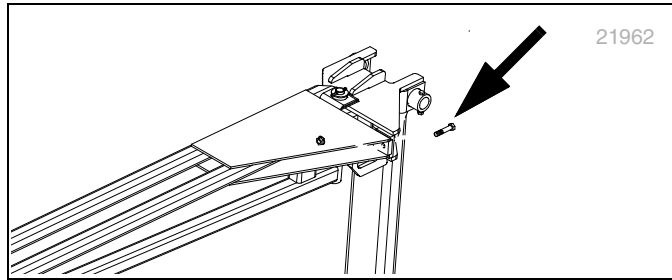

If an identical Grade 5 bolt is not immediately available, temporarily substitute a metric M12 x 1.5 x 6.4 mm Class 8.8 bolt and nut.

If conditions are causing frequent shears, keep spare bolts in the storage holes of the marker shear base.

**Marker Disk Lubrication**

If the grease seal cap (1) for the marker disk hub bearings is damaged or missing, disassemble and clean the hub. Repack with grease and install a new seal or grease cap.

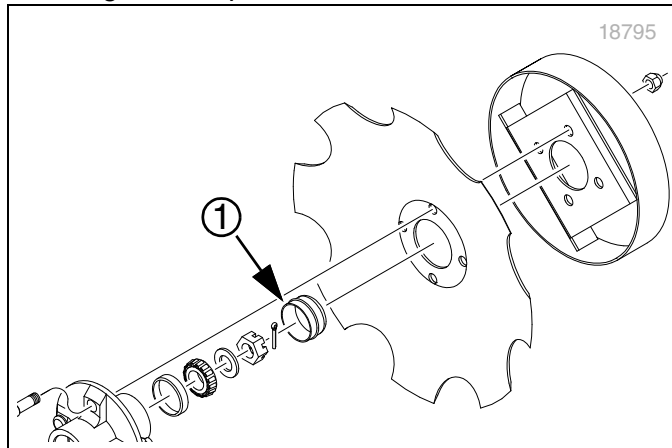

**In-Cab Consoles**



**Component Damage Risk**

When cleaning the planter, to avoid damage do not powerwash on or around these electrical component including the in-cab consoles.

Avoid the direct spray of water on in-cab consoles as it could compromise the console housing and cause damage. Keep all electrical connections free of dirt and grease and do not tightly bind electrical cords. Disconnect the electrical harness whenever parked.

Between planting seasons, store any in-cab consoles inside a dry environment free from pests, temperature variances.

**Material Clean-Out**



**Possible Dust and Chemical Fume Hazards**

Clean-out can create dust and fumes from seed residue and seed treatment. Wear a respirator and any other protective equipment specified by the seed and/or seed treatment supplier.



**Entrapment and Suffocation Hazards**

A seed hopper that is full, or appears full, can be an entrapment hazard. You can sink all the way into the grain and suffocate in a matter of seconds. Never enter a seed bulk hopper for loading, unloading, or routine maintenance. Keep lid tightly closed during operation.



**Clean-Out Door Damage Risk**

Verify clean-out doors are closed before folding or unfolding the planter to avoid damage to the doors.



**Planter Damage Risk**

Do not remove the strainer from the hopper as it prevents larger foreign matter from clogging the air system.

When planting is completed, it is common for some seed to remain in the bulk seed hopper, airbox, hose lines, and meters.

The following sections will complete a system material clean-out:

- Bulk seed hopper clean-out
- Air box clean-out
- Air system clean-out
- Seed meter clean-out
- Seed tube clean-out
- Fertilizer clean-out, if installed

If using the probox seed box, remove the probox seed box, if desired or slide door closed before cleaning the rest of the material from the planter.

**Bulk Seed Hopper Clean-Out**



**Possible Dust and Chemical Fume Hazards**

Clean-out can create dust and fumes from seed residue and seed treatment. Wear a respirator and any other protective equipment specified by the seed and/or seed treatment supplier.

When planting is completed, it is common for some seed to remain in the seed hoppers, air box, hose lines, and meters.

**To do a complete system clean-out:**

1. Empty the air box (and bulk seed hopper, if desired).

2. Blow residual seed to the meters.
3. Clean out the meters with the fan running.

### Air Box Clean-Out



#### **Clean-Out Door Damage Risk**

Verify clean-out doors are closed before folding or unfolding the planter to avoid damage to the doors.

Perform air box clean-out with the fan off.

#### To perform air box clean-out:

1. Place a tarp or large container under the air box to catch the seed.
2. If cleaning the air box with seed in the bulk seed hopper, or to clean out air box because of an obstruction:
  - a. Loosen the wing nuts (1) and slide the door cover up on each side of the air box. Ensure the slots (2) are uncovered. Tighten wing nuts.
  - b. Remove the shut-off gate (3) from storage position and slide into slots. Secure with lynch pin.

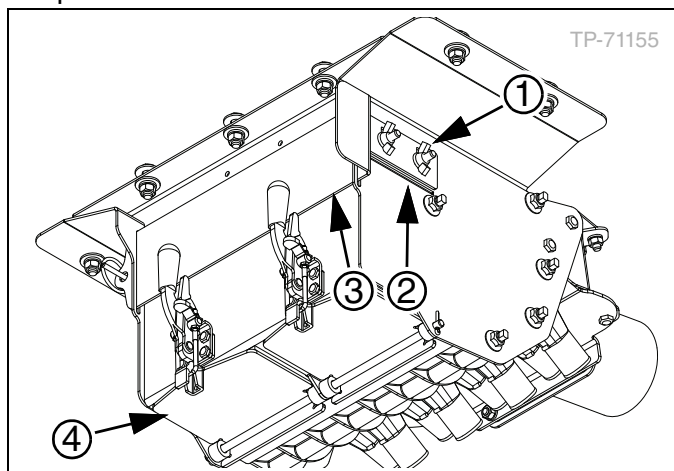

3. Open the clean-out doors (4) on the bottom of the air box. Seed in the air box will immediately fall out of the air box.
4. Tap on the sides of the air box to dislodge any seed.
5. Close the clean-out doors. Return the shut-off gate to the storage position and close the door cover.
6. Perform an air system clean-out to remove any remaining seed from the air box and all seed in the meters.

### Air System Clean-Out

#### To perform air system clean-out:

1. Place a tarp or large container under the air box clean-out to catch seed.
2. Open the air box clean-out doors to empty seed from the air box.

If there is seed in the bulk hoppers to be emptied, the shut-off gate can be inserted (see “<Bold>Air Box Clean-Out”) to control seed flow.

3. Close the air box clean-out doors.
4. Turn on the delivery air fan and let it run.

If most of the meters are shut off, reduce the fan speed as necessary to obtain a low meter pressurization.

5. Start at one end of the planter and clean out the meter. See “**Meter Clean-Out Container**” on page 64. Use a bucket or the funnel to catch the seed.

- a. Use the meter gate to start and stop seed flow if using a small container.
- b. Close the meter gate.
- c. Repeat the procedure for all meters.
6. During air system clean-out, it is common for a few seeds to dislodge and make their way to meters already cleaned. To avoid future problems when the next disk is used, and to avoid crop mixing, open and close all meter gates to remove any stray seed.

#### Air Box Residue Clean-Out



#### **Clean-Out Door Damage Risk**

Verify clean-out doors are closed before folding or unfolding the planter to avoid damage to the doors.



Flushing the air box with water is not recommended. If this is done, you will need to operate the fan for an extended period to completely remove any moisture before storing or before field operations.

Planting in extremely dusty conditions, particularly dusty and humid conditions, can lead to dusty buildup inside the air box. This residue can cause seed delivery blockages.

If there is seed in the bulk hoppers, insert the shut-off gate in the air box (see “<Bold>Air Box Clean-Out”).

Open the clean-out doors and inspect the inside of the air box. If any areas inside the air box are

partially or completely blocked, follow the clean-out instructions below.

**To perform air box clean-out:**

1. Park the planter at a suitable location for clean-out.
2. Set out a tarp to recover any seed still in the air box.
3. With the shut-off gate (3) still in place, open the air box clean-out doors (4).

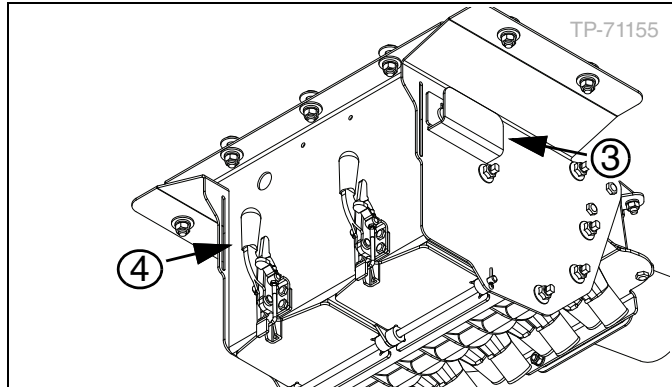

4. Use a marker to identify the hoses on the seed hose ports.
5. Disconnect the clamps and remove the hoses. Further disassembly of the air box is not recommended.
6. Break up any buildup. Use a seed tube brush, hooked tool, or wire to clean out smaller fragments. Use a vacuum to clean out the rest.
7. Inspect the seed hose ports. Break up any deposits and vacuum out from the clean-out doors.
8. With all ports and doors open, operate the planter fan to blow up any remaining loose residue.
9. Reconnect the seed hoses.
10. Close the clean-out doors. Return the shut-off gate to the storage position and close the door cover.

**Meter Clean-Out Container**

A container for meter clean-out is stored at the left end of the planter. This container can hold all the seed in a meter and inlet.

The container can also be converted to a funnel for complete system clean-out.

Material and tools needed for the conversion are:

- A length of 1-3/8 inch (3.5 mm) ID hose (2).

- A worm drive clamp (3) with a working diameter of 1-3/8 inch to 2-1/4 inch.
- A hacksaw with a fine-toothed blade.



The funnel wall is thin ABS. Scissor-type pipe-cutting tools may fracture it. Rotary-type pipe cutting tools may slip off.

**To convert the container (1):**

1. Trim the sump (4) with the hacksaw.
2. Slide the hose (2) fully onto the funnel tip.
3. Secure with the clamp (3). Do not over-tighten the clamp or the funnel wall will be crushed.

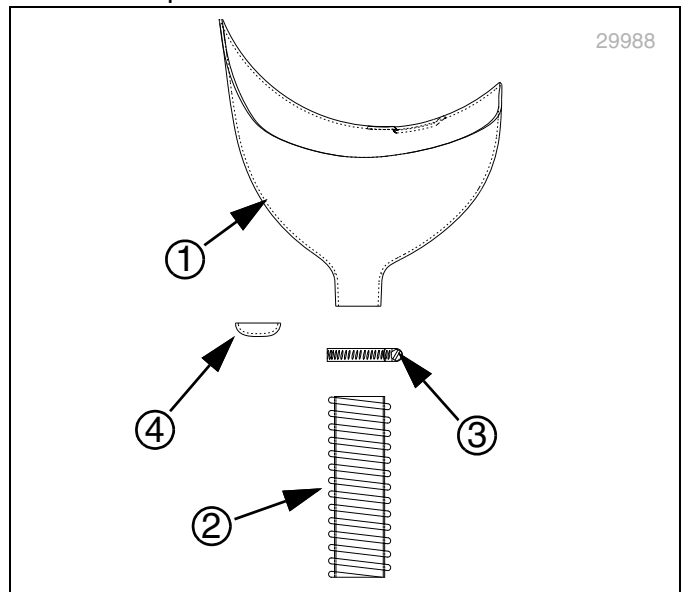

**Meter Clean-Out**

Attach the container/funnel to the housing of the seed meter to free your hands for other tasks during clean-out.

**To perform meter clean-out:**

1. Close the seed inlet gate on the meter to minimize the seed volume when the disk is removed.
2. Remove the rain cover. The container/funnel cannot be snapped in place with the rain cover installed.
3. Align the left (rear) end of the container/funnel lip (1) with the top of the lower (rear) rain cover latch ear.
4. Place the right (front) end of the container/funnel lip (2) between the meter housing and the seed tube.

5. Rotate the container/funnel forward until the slot engages a tab on the bottom center of the meter housing (3).

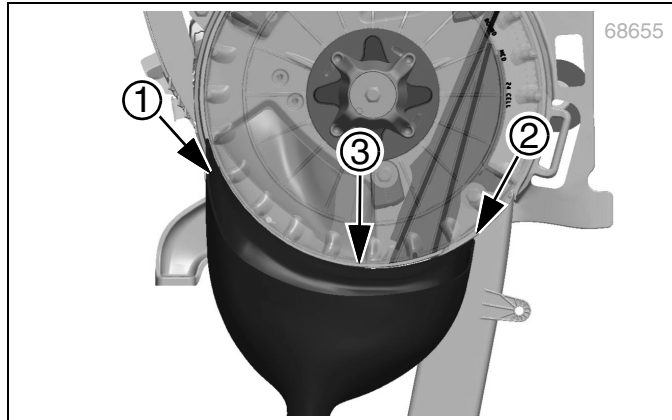

6. Remove the seed disk.
7. Slowly open the seed inlet gate to empty the seed.
8. If the air system is running, there may be more seed than the container can hold. Use the seed inlet gate to turn off seed flow to empty the container.
9. Clean seed from all brushes. A shop vacuum is recommended to clean the brushes.
10. Inspect the brushes.
11. Rotate the container/funnel clockwise to remove and empty.
12. If the planter will be used again:
  - a. Install the next seed disk for the operation.
  - b. Set the inlet gate for the seed.
13. If the planter will be stored:
  - a. Close the seed inlet gate.
  - b. Do not put a seed disk back in the meter.
  - c. Reinstall the rain cover.

**Alternate Meter Clean-Out**

Use a shop vacuum cleaner with a narrow hose nozzle to clean out a meter.

- Close the seed inlet gate.
- Release the disk clamp while holding the seed disk against the meter.
- Tip the top of the disk away from the meter.
- Insert the shop vacuum hose nozzle and remove the seed.
- Open the gate to allow seeds in the inlet and the drop hose to flow to the shop vacuum hose nozzle.

**Seed Tube Clean-Out**

The seed sensor in the seed tube can have a buildup of dust, dirt, and seed treatment which can cause false low population alarms.

If the seed meter is empty, remove the seed disk and insert the seed tube brush (part number 891-259C) into the seed tube from above. With the planter raised, you can insert the brush from below, whether the meter is empty or not.



**Fertilizer Tank Clean-Out**



**Agricultural Chemical Hazard**

*Some chemicals will cause serious burns, lung damage, and death. Avoid contact with skin or eyes. Avoid prolonged breathing of chemical fumes. Wear respirator and other protective equipment as required by chemical manufacturer. Seek medical assistance immediately if accident occurs. Know what to do in case of an accident.*



**Chemical Hazard**

*Store and dispose of unused chemicals as specified by the chemical manufacturer.*

**To perform fertilizer tank clean-out:**

1. If the pump has already been filled with RV antifreeze for storage, close the pump valve.
2. Move the planter to a location suitable for draining the material. A site with access to rinse water is best.
3. Open the quick-fill valve to allow leftover material to drain.
4. Open the tank lid. Check for build-up, sedimentation, and foreign matter, particularly any large objects.
5. Slowly open the tank valve handle.
6. Power-wash the inside of the tank from above.
7. When the tank is clean and drained, close the tank valve.
8. Close the tank lid.
9. Wash all spilled fertilizer off the planter.

## ■ Seed Meter Brushes



### **Possible Chemical Hazard**

*Brushes will have talc and graphite residue, and may have residue of hazardous seed treatments. Wear a respirator for brush cleaning.*

A HEPA vacuum cleaner is recommended for brush cleaning. Washing brushes is not recommended and may cause matting. Do not scrape the brushes with sharp instruments.

With proper maintenance, bushes normally last several seasons before needing replacement.

The first indications of excess brush wear or damage are normally observed on the console or in air system operation

- If the tufted brushes (1) are worn or damaged, the seed doubles rate rises, increasing population.

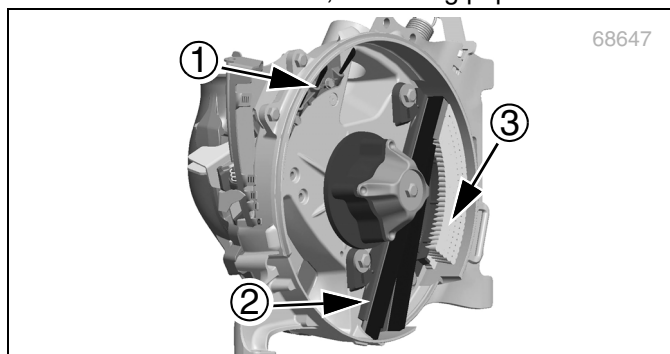

Finding an occasional cracked seed hung up on a tuft fiber is not uncommon, and is not an indicator that brush maintenance is required. Remove the seed and continue with operations.

- If the strip brushes (2) are worn or damaged, air pressure regulation may become unstable or require increasing fan speed over time.

If recommended fan rpm ranges need to be exceeded, the regulated air system may be taking too much air due to meter leakage.

In severe cases, seed may leak past the strip brushes, causing spikes in population. If seed is frequently seen between the strip brushes, one or both may need replacement.

- If the seed drop brush (3) is worn or damaged, its anti-static effect may fade, which can result in skips due to smaller seeds failing to release, and lower population.

If an obvious groove is worn in the drop brush, replace the brush.

### **Seed Meter Brush Replacement**

Brushes are designed for long life and last multiple seasons before needing replacement. Excess doubling that does not respond to adjustments are an indication when brushes are worn out.

See the Parts manual for current brush replacement part numbers.

### **Tufted Brush Replacement**



#### **Performance Risk**

*It is critical that no debris be caught between the tufted brush and mounting surface. Even objects as thin as paper can negatively impact meter performance.*



#### **Fracture Risk**

*Do not tighten the fasteners to normal torque or the brush plate may fracture.*

### **To replace tufted brush:**

1. Remove and save both bolts (1) and nuts.

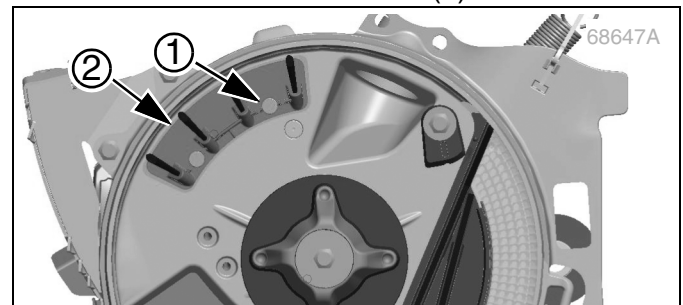

2. Remove the tufted brush assembly (2), and replace with a new assembly.
3. Insert the bolts and start the nuts. Carefully tighten each nut just until there is no play under the screw heads.
4. Add a half turn to the nuts.

### **Strip Brush Replacement**

Do not loosen or remove any of the bolts (1) retaining the brush holder.

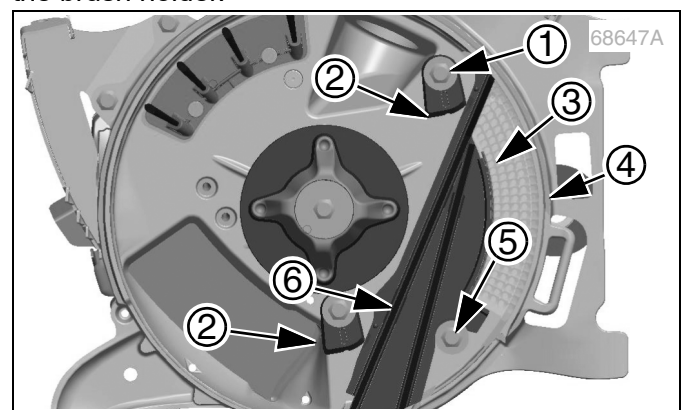

### **To replace strip brush:**

1. Insert the flat blade of a large screwdriver into the slots of the brush holder snaps (2).
2. Turn each snap clockwise to release the brush holder (3).
3. Be prepared to catch the drop brush (4) which will fall loose.
4. Slide the brush holder left and up to free the front edge from under the washer (5).
5. Remove the brush holder.
6. Remove used strip brushes (6) from the holder by sliding them down out of the grooves.
7. Insert replacement strip brushes in the grooves at the holder bottom so the notched ends (7) are at the bottom.



8. Insert the brush holder and check the strip brush positioning.
  - a. The ends of the long brush must fit snugly into the meter housing grooves at the top (8) and lower rear (9).

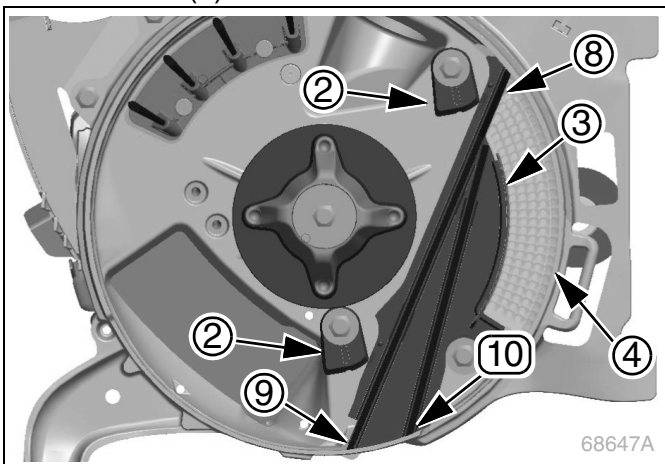

- b. The bottom end of the short brush must fit snugly in the lower front housing groove (10).
  - c. If any significant force is required to seat the brush holder, a strip brush is likely too high or too low.

9. When the strip brushes fit correctly, position the drop brush (4), and seat the brush holder (3).
10. Starting with the bottom snap, swing the snaps (2) back in place.

**Seed Drop Brush Replacement**

To replace seed drop brush:

1. Insert the flat blade of a large screwdriver into the slots of the brush holder snaps (2).

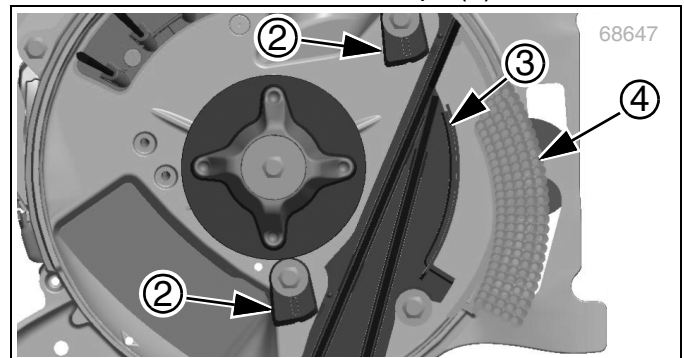

2. Turn each snap clockwise to release the brush holder (3).
3. Prepare to catch the drop brush (4) which will fall loose.
4. Slide the brush holder left and up.
5. Remove the drop brush.
6. Position a new drop brush so the brush is flat against the back of the meter housing, and under ridges on the leading edge of the brush holder.
7. Slide the brush holder forward and down to engage the drop brush.
8. Starting with the bottom snap, swing the snaps (2) back in place.

**Knockout Brush Replacement**

To replace knockout brush:

1. Remove the knockout brush (1) from the seed meter rain cover.

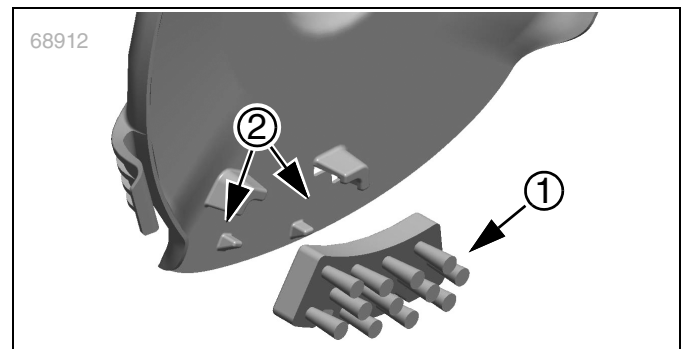

- Position the new knockout brush under tabs (2) and snap in place.

### Seed Disk Maintenance

When removing seed disks, inspect for wear and damage. If there is any seed dust or treatment buildup in the cells (1), or along the raised wiper ridges (2), clean the disks and reinspect.

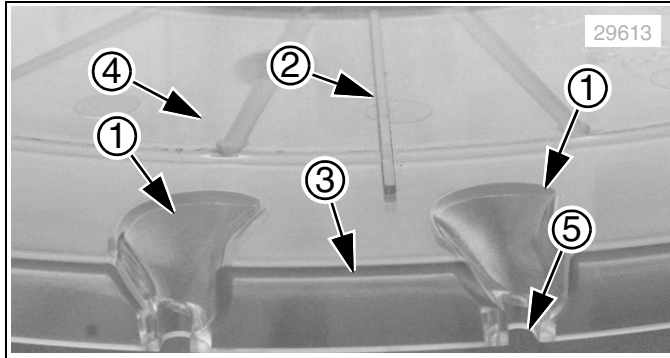

Replace the disks for:

- Chips at the outer edge (3). These chips will leak air.
- Chips at the edges or in surfaces of the cell pockets (1). These chips can leak air and/or affect singulation.
- Cracks over 2 inch (5 cm) long in the working face (4) of the disk, or any cracks in the ridges or grooves on the face.
- Warping - if any part of the disk does not press firmly on the seed drop brushes in operation.
- Wear - if a wiper ridge (2) is worn away.  
If the cells are worn through, or the air ports (5) have enlarged, replace the disk.

### Cleaning and Storing Seed Disks



#### Possible Chemical Hazard

Seed disks will have talc and graphite residue, and may have residue of hazardous seed treatments. Do not wash disks where food is prepared or where cookware or dinnerware is washed. Wear gloves when washing disks. Avoid spray.

Use warm or hot water, mild soap, and a sponge or soft brush to remove buildup on seed disks.

If disks are washed, allow to dry completely before storage.

Keep original shipping cartons for disk storage. Otherwise, store on edge (not leaning), or stacked horizontally on a spindle, to eliminate any risk of warps.

Any seed residue on disks may attract pests. Fully enclose dry disks to prevent rodent damage.

## Chains

### Chain Lubrication

Lubricate chains any time there is a chance of moisture, and when being stored at the end of the planting season. Use a multi-purpose spray lubricant.

### Chain Slack

Initially check the drive chains after the first 8 hours of drill use. The new chain slack tends to increase during the first few hours of operation due to seating. After the first 8 hours, check the chains seasonally.

- Measure the span (1) for allowable slack:  
Locate the longest span of each chain (usually the span which does not run through the idlers).

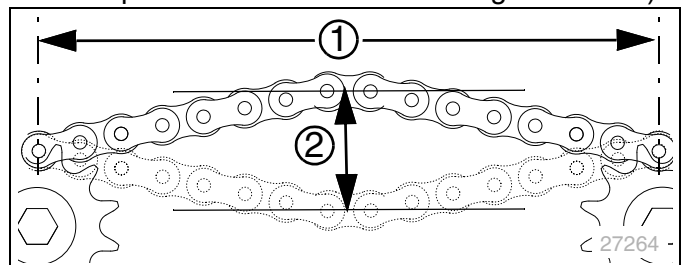

- Determine the ideal slack:

Chain Type	Chain Slack
Long chains over 36 inch (91 cm)	1/4 in/ft (2.1 cm/m)
Vertical short chains	1/4 in/ft (2.1 cm/m)
Horizontal short chains	1/2 in/ft (4.2 cm/m)

- Measure the current slack (2):  
At a right angle to the chain span at the center of the span, deflect the chain in both directions. The slack is the distance of the movement.
- Adjust the idlers for ideal slack.

### Chain Clips

Whenever mounting a chain, ensure the clip at the removable link is positioned to minimize snags.

Install the clip with the open end facing away from the direction of chain travel.

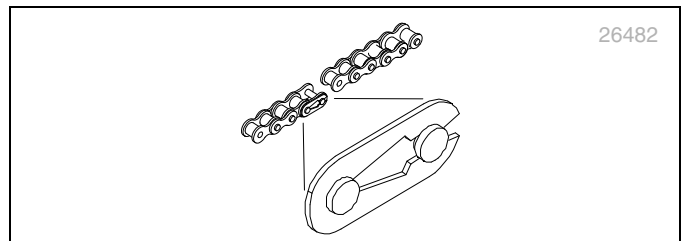

### Seed Meter Drive Chain

When performing seasonal checks, lower the planter to put the chain at minimum idler spring tension.

Lift the spring off the idler assembly. Check that the idler pivots freely. Re-attach the spring.

## ■ Side Depth Wheels



### Sharp Object Hazard

*Disks are sharp. To avoid serious injury, wear gloves when working in this area.*

1. Lift the side depth wheel off the ground.  
Move the tire in and out to inspect for end play.  
Inspect for roughness in the bearing by rotating the wheel. If the bearings are rough, inspect and replace if necessary.
2. The side depth wheels are preset at the factory. With normal wear, it may become necessary to make adjustments so the wheel remains close to the disk.  
Loosen the clamp bolt (1) and slide the depth wheel arm (2) in to take up the gap between the wheel and disk.  
If more adjustment is needed:
  - a. Remove the bolt (3) and wheel (4).
  - b. Remove the shims (5) from the inside of the wheel and place them on the outside of the wheel (6).  
Always place removed shims from the inside to the outside. When installed, the wheel should turn freely and not hit the arm at the curve. Do not add any more shims than necessary.
  - c. Disassemble the depth wheel arm (2) from the row unit.
  - d. Remove the bushing (7) from the sleeve (8) and check for wear. If necessary, replace the bushing.
  - e. When reinstalling the depth wheels, align the tab on the hex adjustment (9) with the notch in the bushing. Install the bolt and tighten.

- f. Adjust the depth wheels. See “Side Depth Wheel Adjustments” on page 49.

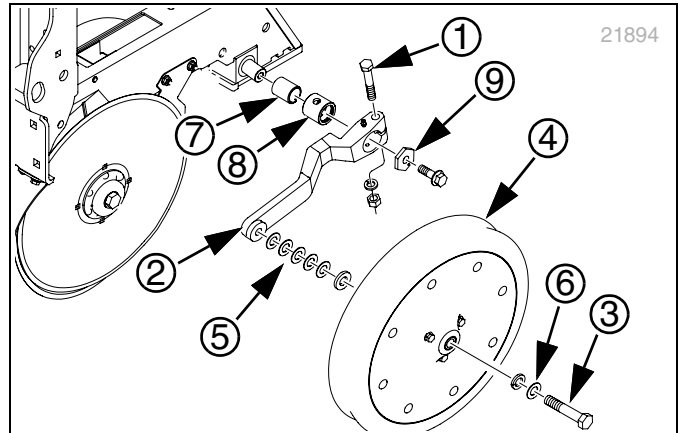

## ■ Disk Separators and Scrapers



### Sharp Object Hazard

*Disks are sharp. To avoid serious injury, wear gloves when working in this area.*

1. Remove the side depth wheels from the arms to access row unit disks and scrapers.
  2. With the unit raised, check the disk separator (1) for wear. Replace separator if it is 1/2 inch (13 mm) wide or narrower. To replace:
    - a. Remove the disk (2).
    - b. Drive out the roll pins (3).
    - c. Install the new spreader.  
For proper operation, the scraper separator must be a little loose in the holder and between the blades.
  3. When reinstalling disks, put two shim washers (4) between the bearing and shank on each disk. Tighten the bolts.
- i** You may need fewer inside shim washers on worn disks. Check disk contact. See page 49.
4. Check that outside disk scrapers (5) are formed to the disks to help remove any mud. Bend or twist the scrapers to fit the disks as necessary.  
After every 200 acres (80 hectares) of operation, check outside scrapers for proper adjustment

and wear. Replace the outside scrapers as necessary.

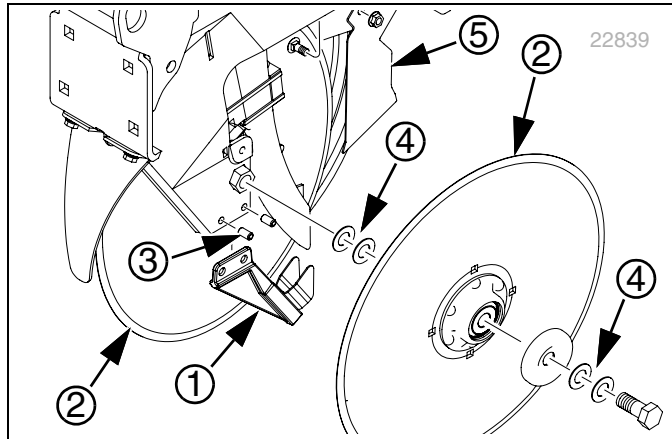

### ■ Seed Flap Replacement

To replace a seed flap (1):

1. Use a needle nose pliers or similar tool to grasp the **T** at the top of the flap.
2. Pull up to pull the flap up out of the metal bracket (2).
3. Push the new seed flap down through the metal bracket until the flap snaps into place with the **T** top resting on top of the bracket.

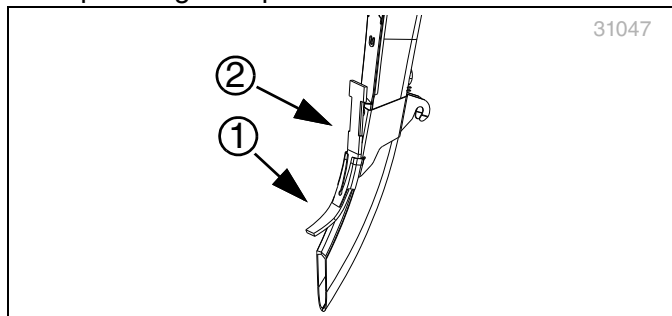

### ■ Fertilizer System



#### **Agricultural Chemical Hazard**

*Some chemicals will cause serious burns, lung damage, and death. Avoid contact with skin or eyes. Avoid prolonged breathing of chemical fumes. Wear respirator and other protective equipment as required by chemical manufacturer. Seek medical assistance immediately if accident occurs. Know what to do in case of an accident.*



#### **Pump Damage Risk**

*Do not leave fertilizer or fertilizer residue in the pump. Do not allow air to enter the pump. Even for short periods of storage, air entering the pump causes rapid and severe corrosion.*

Proper attention to maintenance, end of the day clean-out, and end of season clean-out and

winterization, can substantially increase the life and reliability of your fertilizer system.

Protect the pump, and clean the tanks, strainers, lines, and nozzles to avoid costly and time consuming repairs at the next season.

Fertilizers are usually highly corrosive to metals other than stainless steel. Suspension fertilizers can clog system components in storage.

Refer to the pump manual for detailed maintenance.

1. Flush the entire system with clean water. Do this at the field last treated, or other location compliant with the chemical supplier clean-up instructions.
2. Remove the strainer and drain it. Drain all lines and tanks completely to prevent freezing damage.
3. Flush the pump according to the pump operator manual. Fill the pump with RV antifreeze and cap off.

### Liquid Fertilizer Strainer

The fertilizer system uses an in-line strainer to keep damaging particulates out of the pump. The strainer can become clogged over time, reducing the pump rate. Clean the strainer several times per season. Do not wait until application rates fall below target. Higher quality liquid fertilizers may require less frequent cleaning. Disassemble and clean the strainer before storage to prevent caking.

### In-Season Filter Cleaning

1. Shut off the ball valve at the filter to minimize product spill.
2. Unscrew and remove the bottom canister (1) of the filter (2).

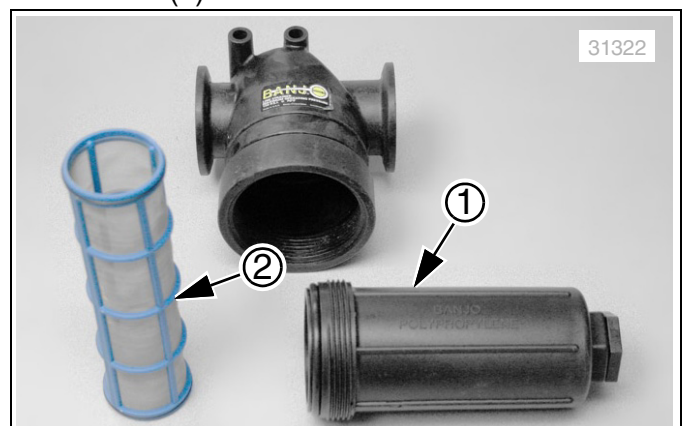

3. Wash the filter cartridge (2) with water or replace with new cartridge, if necessary.

4. Reinstall the cartridge, canister, and turn on the ball valve.

**End of Season Filter Cleaning**

1. Load 10 to 15 gallons (40 to 60 liters) of clean water in the tank.
2. Pump most of the water through the system. If doing this by hand-turning the ground drive wheel, first install the largest drop-line orifice size and set the pump adjuster to maximum to increase flow.
3. With the valves open, remove the filter canister.
4. Clean the strainer and canister.
5. Fully drain the tanks and lines.
6. Reinstall the strainer and canister.
7. Add 2 pt (1 liter) of RV antifreeze to each tank.
8. Pump until the tank is just empty. Some fluid will remain in strainer.
9. Open the supply line above the pump inlet. Add RV antifreeze and operate the pump until it is filled.

**■ Lubrication**

If any movable parts such as levers, pivots, and clamps are not moving smoothly due to rust or hindering material, do not attempt to force parts into motion. Instead, remove the rust or unwanted material and apply oil or grease on the relevant spot. Otherwise, machine may become damaged through impaired usage.

**Grease Fittings**

Lubricate with grease at the hourly interval indicated in the arrow. If you operate the machine in extremely wet and/or muddy conditions, lubricate grease fittings more frequently.

**Two-Point Hitch Pivot**

Grease one grease fitting under the two-point hitch. Apply until grease emerges.

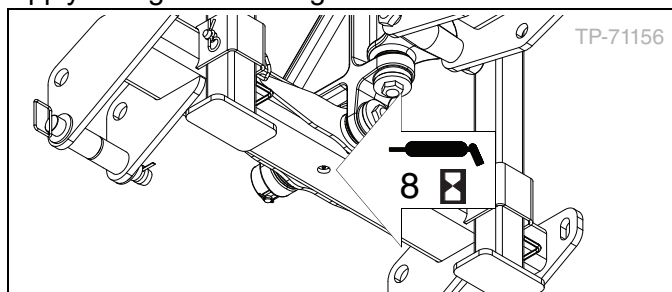

**Two-Point Hitch to Tongue Pivot**

Grease one grease fitting at the tongue pivot. Apply until grease emerges.

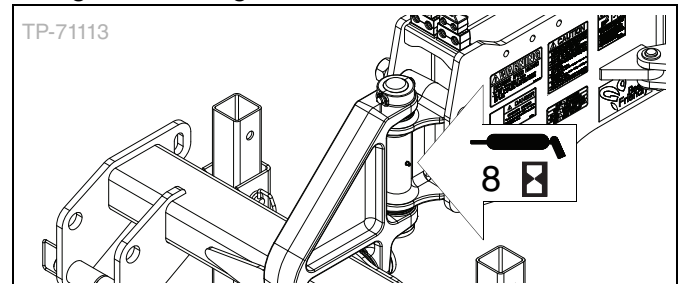

**Side Depth Wheel Bushing**

Grease only the top two grease fittings on each side of each row unit. Apply until grease emerges.

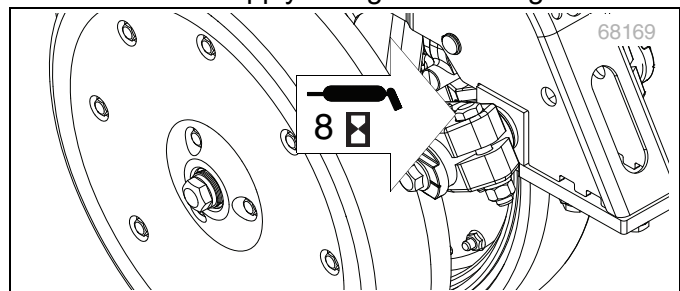

**Chain Drive Wing Transfer Driveline**

Grease two grease fittings each side. Apply until grease emerges on the joints.

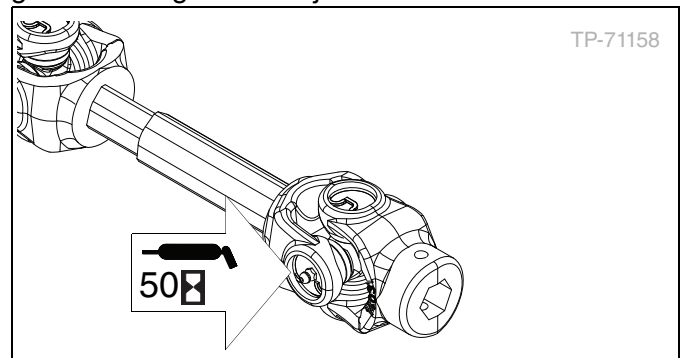

**Bearings**

**Wheel Bearings**

Repack two bearings on each wheel.

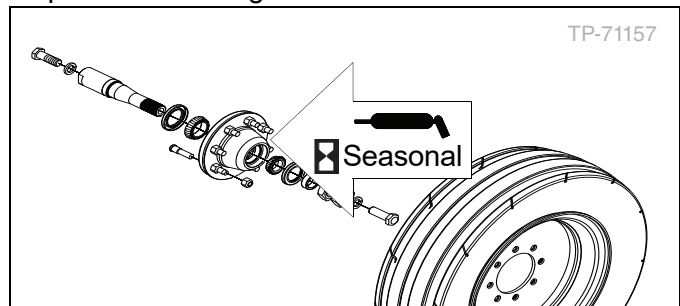

### Marker Disk Hub Bearings

Repack two bearings on each marker.

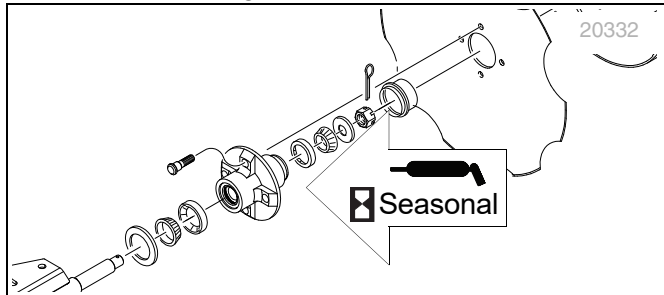

### ■ Storage



#### **Possible Chemical Hazard**

Seed disks will have talc and graphite residue, and may have residue of hazardous seed treatments. Do not wash disks where food is prepared or where cookware or dinnerware is washed. Wear gloves when washing disks. Avoid spray.



#### **Component Damage Risk**

When cleaning the planter, to avoid damage to IRC components, do not powerwash on or around these electrical components.

Store the planter where children do not play. If possible, store inside for longer life of the planter.

1. Complete all instructions in “**Parking**” on page 58.
2. Clean-out all material from the planter.
3. Lids:
  - **Bulk Hopper planters** - unlatch the hopper lids so that the seals are not in compression during storage.
  - **Row hopper planters** - latch hopper lids.
4. Route a chain or security cable through the hold-down U-bolt and the latch handle to prevent unauthorized entry, and prevent high winds from opening the lid.
5. Remove seed disks from seed meters to relieve pressure on the brushes. Clean the disks of residue buildup. See “**Seed Disk Maintenance**” on page 68.
6. Thoroughly clean seed and seed treatment residue from seed meters. See “**Meter Clean-Out**” on page 64.
7. Close seed inlet gates at the meters, and tie or tape a small plastic bag over the ends of all seed delivery tubes to prevent pests from entering.
8. For planters with the optional fertilizer package:

- a. The pump, strainer, and manifold system require special attention before storage. See “**Fertilizer System**” on page 70.
  - b. Clean the tanks and application hoses. Be sure to follow the chemical manufacturer’s instructions when handling chemicals.
  - c. Thoroughly clean the pump following instructions in the pump manual.
  - d. Remove any dirt and debris that can hold moisture and cause corrosion.
9. Clean the planter of mud, dirt, excess oil, and grease.
  10. Lubricate all points according to “<Bold>Lubrication” beginning on page 71.
  11. Apply grease to exposed cylinder rods to prevent rust.
  12. Inspect the planter for worn or damaged parts. Make repairs and service during the off season.
  13. Use spray paint to cover scratches, chips, and worn areas on the planter to protect the metal.
  14. Cover the planter with a tarp if stored outside.

### ■ Inside Disk Scraper Installation

Start with the left-hand row unit and repeat the following steps for each row unit.

#### **To install inside disk scraper:**

1. Insert bolt (1) from the rear, through the lowest hole of the bracket (2).

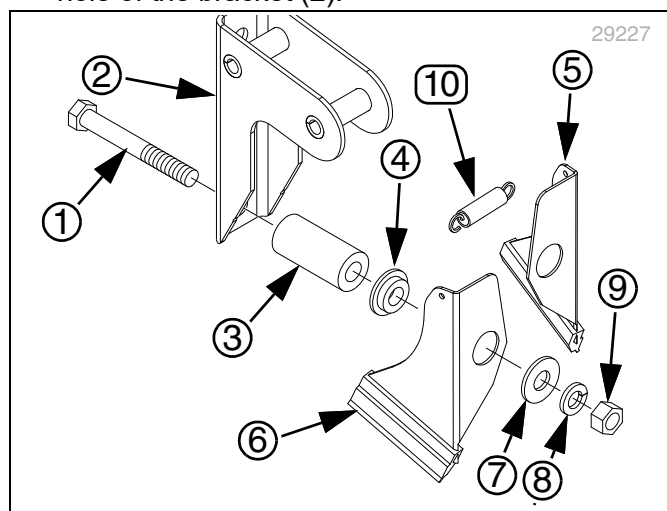

2. Place the tube (3) over the bolt (1).
3. Place the spacer (4) on the bolt (1) with the larger diameter toward the bolt head.
4. Put the left scraper blade (5) on the spacer (4), followed by the right scraper blade (6).

5. Fasten the scraper assembly with a flat washer (7), lock washer (8), and nut (9).
6. Tight the nut to torque from the “**Torque Value Chart**” on page 118. Ensure the disks pivot freely.
7. Install the spring (10) by connecting the spring between the disks using the small top holes.
8. Remove one or both opener disks to gain access to the opener frame (11).

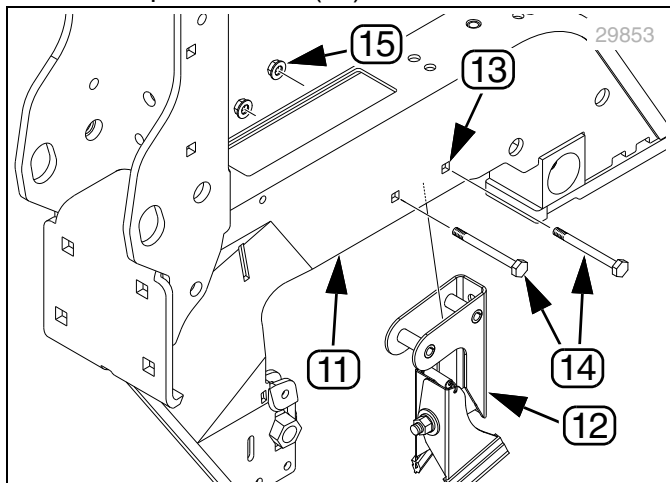

9. Install the scraper assembly (12) between the middle four lower square holes (13) of the opener frame.
10. Secure with two bolts (14) and whiz nuts (15).
11. Reinstall the disk.

# Troubleshooting

When starting with a new planter, a new crop, or a new population, it is important to physically check what the console is reporting by digging and observing seeds. This is to verify that the planter is set up correctly to plant the desired population. Do not rely only on the population reported by the console.

Plant a short distance and dig the seeds, or run with the closing wheels wired up to leave an open seed trench. Based on seeds found, determine an average distance between seeds. Compare the distance between seeds to the seed spacing listed in the charts for your population.

Also, during start up you may encounter alarms and readouts on the console that do not make sense. It is critical to troubleshoot these alarms, not only to ensure the planter drive is set properly to hit the target population, but also to fix incorrect entries in the console to eliminate nuisance alarms. For console issues, see the console operator manual.

Before going to the troubleshooting charts to remedy a console or population problem, use the following chart. Finding what is wrong comes from knowing what the planter is actually doing in the soil.

1. Is the spacing on the ground correct?	No	Check the ground drive transmission and range sprocket selections, or the population and seeds per revolution settings on a hydraulic drive unit.
	Yes	Go to step 2.
2. Is the reported population 1/2 the actual population, or is the reported population too high by a factor of 2?	No	Go to step 3.
	Yes	An incorrect row spacing value entered in the console can cause this. Correct the row spacing error. The system can also be off by a large factor if incorrect range sprockets are installed. Check seed rate charts against range and transmission sprockets on the planter.
3. Is the population on the console close to the target population?	No	Check seed rate charts against transmission sprockets selection.
	Yes	If slightly under, see <b>“Seed Population Too Low”</b> on page 80. If slightly over, see <b>“Seed Population Too High”</b> on page 82.

## ■ Seed Pool Troubleshooting



### **Foreign Object Risk**

*After clearing a bridge or blockage, check the seed pool at the meter for any debris that might have caused the bridging. Remove the debris to eliminate the risk of an object lodging in a seed cell and causing skips.*

Once planting is underway with the seed pools set, bridging may occur at or above the seed inlet and cause the meter to run empty.

An empty meter causes a Row Failure alarm with a report of the row number. The outside left-hand row is row 1.

To correct the bridging issue:

1. Stop and put the tractor in park. Leave the fan running.
2. Locate the failed row. Remove the rain cover to verify the meter is empty. Check the gate setting.

3. Temporarily open the gate one or two notches wider.

- a. If the problem was bridging at the gate, seed should flow into the meter immediately.
- b. If little or no seed flows into the meter with the gate open wider, the problem is further up in the seed flow.

Close the gate completely for about 15 seconds. This prevents meter pressurization air from opposing seed delivery. Gently tap on the seed inlet. Re-open the gate and see if seed now fills the meter.

4. If no obvious foreign object was the cause of the bridging, the gate setting may have been too small for the seed. Ensure all operating rows were at the correct initial gate setting. If so, reset the gates to the next higher opening.

**Bulk Hopper Planters**

The following illustration shows rear cross sections of the seed meter in normal and row-failed conditions.

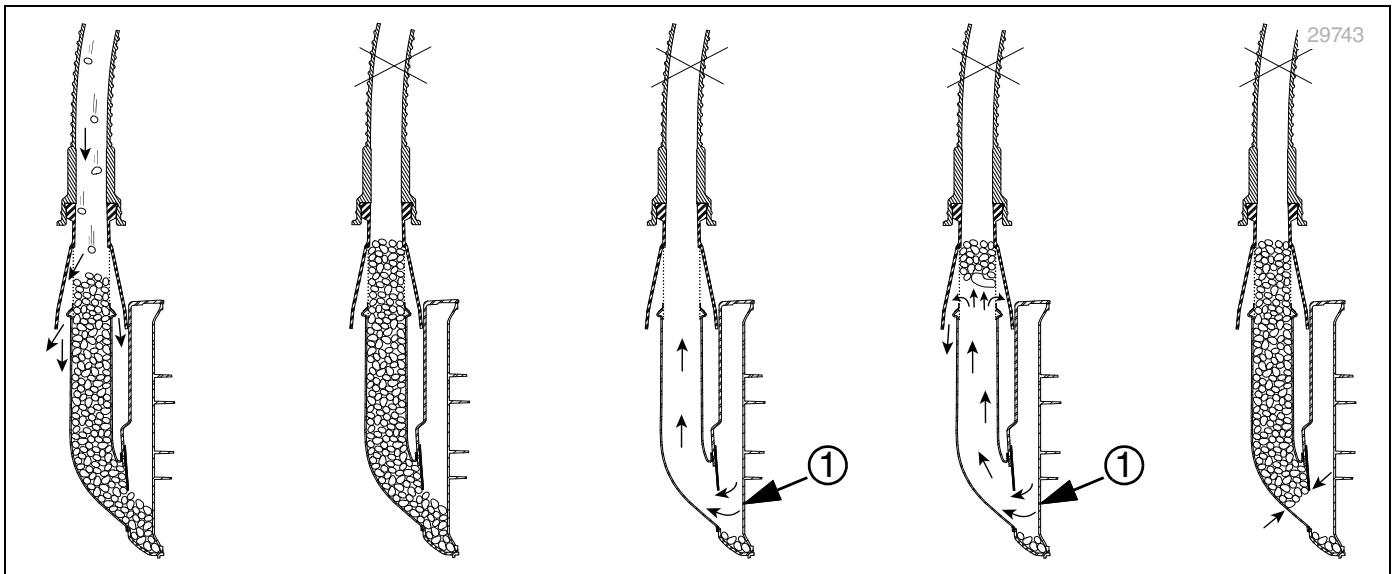

Normal: Filling	Normal: Filled	Delivery Blockage or Back-flow Starvation	Bridging: Screen	Bridging: Gate
<p>Seed pool at the seed inlet gate prevents back-flow of meter pressurization air, allowing the seed to flow from the delivery system, filling the inlet to the top of the air release screen.</p>	<p>Once the inlet is filled to the top of the air release screen, the air flow from the delivery system is blocked. No further seed arrives until planting reduces the backlog at the inlet.</p>	<p>No seed is arriving from the manifold. Air back-flow (1) is occurring. Causes may include:</p> <ul style="list-style-type: none"> <li>● meter never primed by row fill</li> <li>● low fan speed</li> <li>● air box or seed hose blockage</li> <li>● no seed available</li> <li>● excess meter pressure</li> </ul>	<p>Oversize matter in the seed has caused a bridge at the top of the inlet. Air back-flow (1) is occurring. When the bridge is released, the seed pool will be insufficient to prevent back-flow.</p>	<p>A bridge at the gate is blocking flow. Causes may include:</p> <ul style="list-style-type: none"> <li>● oversize seed</li> <li>● gate setting too low</li> <li>● oversize matter in the seed</li> <li>● excess meter pressure</li> </ul>
<p><b>Actions</b></p>	<p><b>Actions</b></p>	<p><b>Actions</b></p>	<p><b>Actions</b></p>	<p><b>Actions</b></p>

<b>Normal: Filling</b>	<b>Normal: Filled</b>	<b>Delivery Blockage or Back-flow Starvation</b>	<b>Bridging: Screen</b>	<b>Bridging: Gate</b>
<p>No action required. Continue planting.</p>	<p>No action required. Continue planting.</p>	<ol style="list-style-type: none"> <li>1. Conduct meter fill or row fill. Failure to do this is the most common problem in seed delivery issues.</li> <li>2. Correct the cause of the blockage.</li> <li>3. Perform a one-row seed pool recovery.</li> <li>4. Resume planting.</li> </ol>	<ol style="list-style-type: none"> <li>1. Close the seed inlet gate.</li> <li>2. Disconnect the hose at the meter.</li> <li>3. Tap on the air release screen and inspect.</li> <li>4. Check the seed pool for foreign matter.</li> <li>5. Perform a one-row seed pool recovery.</li> <li>6. Resume planting.</li> </ol>	<ol style="list-style-type: none"> <li>1. If the seed inlet gate is at the suggested opening, increase one notch.</li> <li>2. Check the seed pool for foreign matter.</li> <li>3. Resume planting.</li> </ol>

**Row Hopper Planters**

The following illustration shows rear cross sections of the seed meter in normal and row-failed conditions.

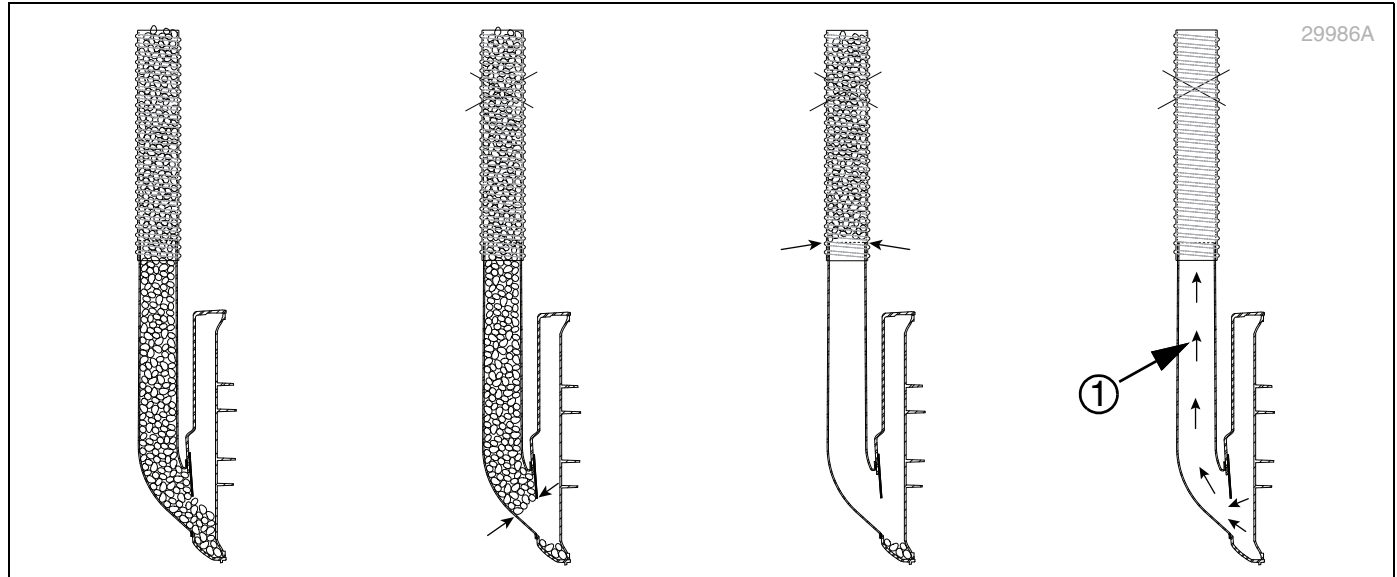

<p><b>Normal: Filled</b></p>	<p><b>Bridging: Inlet Gate</b></p>	<p><b>Bridging: Seed Inlet</b></p>	<p><b>Empty Hopper</b></p>
<p>Inlet is filled to hopper. Seeds move down slowly singulated by the meter.</p>	<p>A bridge at the seed inlet gate is blocking flow. Causes may include:</p> <ul style="list-style-type: none"> <li>● oversize seed</li> <li>● gate setting too low</li> <li>● oversize matter in seed</li> <li>● excessive or sticky seed treatment</li> <li>● excess meter pressure</li> </ul>	<p>Oversize matter in seed has caused a bridge at the top of the inlet. Causes may include:</p> <ul style="list-style-type: none"> <li>● oversize seed</li> <li>● oversize matter in seed</li> <li>● excessive or sticky seed treatment</li> </ul>	<p>No seed arriving from hopper. Causes may include:</p> <ul style="list-style-type: none"> <li>● seed run-out</li> </ul> <p>If hopper is empty, air back-flow (1) is also occurring, which can reduce meter pressurization at other rows.</p>
<p><b>Actions</b></p> <p>No action required. Continue planting.</p>	<p><b>Actions</b></p> <ol style="list-style-type: none"> <li>1. If gate was at suggested opening, increase one notch.</li> <li>2. Check seed pool for foreign matter.</li> <li>3. Resume planting.</li> </ol>	<p><b>Actions</b></p> <ol style="list-style-type: none"> <li>1. Close gate.</li> <li>2. Tap on hopper junction.</li> <li>3. Check seed pool for foreign matter.</li> <li>4. Resume planting.</li> </ol>	<p><b>Actions</b></p> <ol style="list-style-type: none"> <li>1. If row is active, add seed.</li> <li>2. If row is inactive, close seed inlet gate.</li> <li>3. Resume planting.</li> </ol>

### Seed Pool Recovery

When a seed meter has been starved of seed, the back-flow of air through the open seed inlet gate reduces delivery air flow. This causes seed delivery to be slow. If you start or resume planting with an empty seed pool, the delivery flow may be too low to keep the meter supplied. The steps below quickly prime the meter by rebuilding the seed pool.

1. Close the gate (1). This stops the air back-flow.
2. Clear the bridge (2) or blockage that caused the meter to run empty.
3. Reconnect seed hose(s).
4. With the fan running, listen for seed to fall into the inlet (3).
5. Wait for seed fall (4) to taper off and stop.
6. Open the gate to the operating setting.

### 7. Start or resume planting.

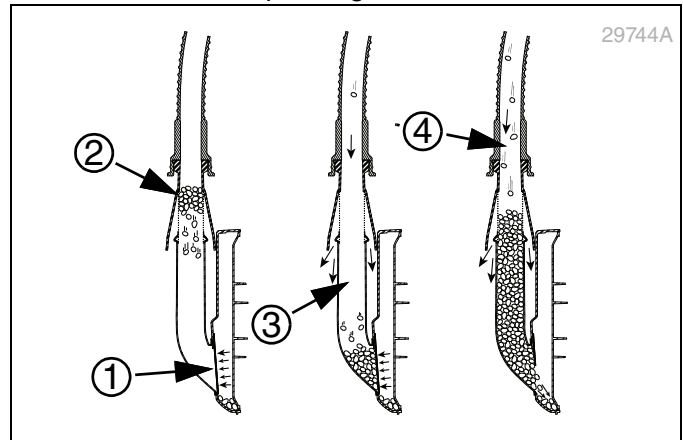

### ■ Seed Population Troubleshooting

Problem	Cause	Solution
<b>Overall population alarms.</b>	False alarms or actual rate errors due to console setup with incorrect row count or spacing	Review planter configuration and console setup.
	Incorrect cell count	Replace seed disks with correct disks, or reset rate for current disks, if within range.
	Improper gap on speed sensor	Check speed sensor (page 15). An incorrect gap can cause an erratic speed signal causing the console to falsely report an improper planting rate.
	Incorrect speed sensor constant	Perform speed calibration, see the console manual.
<b>Low population bands or skips just after turns.</b>	Insufficient oil to the fan, meter pressures low, seeds falling from disks	Perform end-of-pass marker and lift operations separately. If already performing separately, lift more gradually.
<b>Mismatch between reported and furrow population.</b>	Seed tube sensor is not counting all seeds	Clean the seed tube of graphite and dust buildup with seed tube brush. Replace sensors that malfunction.
	Seeds or revolution value in the console setup does not match disk cell count	Correct the value or install correct disk.
	Small seeds, such as milo, are not reliably sensed in the seed tube	Run with rain covers in place to minimize ambient light interference. Use the population adjustment factor in the console system to compensate for missed seeds. For example, change the <i>Population Adjustment</i> values from 100% to 130% as needed. Remember to set this value back to 100% for large seeds.
<b>Unable to adjust air pressure low enough.</b>	Meter pressure fan speed too high or seed delivery fan speed too high	Adjust baffle at the fan.

Problem	Cause	Solution
<b>Seed too shallow or scattered on ground from a single row.</b>	Bottom of seed tube damaged	Replace seed tube. Avoid setting the planter straight down. Use forward motion when lowering.
	Row not penetrating in tire tracks	Increase down force on parallel arm springs.
	Opener depth too shallow	Change side depth wheel setting.
<b>Excessive seed cracking.</b>	Damaged, old, or dried-out seed	Use new seed.
	Incorrect seed cell size	Use correct disk for seed. See Material Rate manual.
	Seed delivery fan speed too high	Reduce the fan speed.
<b>Excess seed remaining.</b>	Field size different	After ruling out population problems, re-check geography.
	Excessive gaps between planter passes	Adjust marker.
	Incorrect speed calibration	Perform speed calibration, see the console manual.
<b>Seed consumption too high.</b>	Field size different	After ruling out population problems, re-check geography.
	Excessive overlap, irregular shaped field	Adjust marker.
	Incorrect speed calibration	Perform speed calibration, see the console manual.
<b>Rows not planted.</b>	Row shut off with IRC or section clutch	Turn on the row.
	If not detected by the console, check for plugged seed tube	Lift the planter, expose bottom of seed tube and clean out.
<b>Uneven seed spacing.</b>	Electric or hydraulic meter drive motor rpm too low for reliable control by proportional valve	Increase field speed. Use a seed disk with lower cell count.
	Excessive field speed	Reduce field speed.
	Unclean seed	Use clean seed.
	Damaged seed tube	Check seed tubes for damage and replace as needed.
	Row unit disks not turning	See <b>“Row unit disks not turning freely.”</b> on page 83.
	Plugged seed tube	Lift up planter, expose bottom of seed tube and clean out.
	Worn or rusted sprockets and/or chain idler or bearings	Check and replace any worn or rusted sprockets or chain idlers.
	Lack of proper seed lubrication on seed	See <b>“Seed Lubricants”</b> on page 38.

Problem	Cause	Solution
<b>Uneven seed depth.</b>	Excessive field speed	Reduce field speed.
	Planting conditions too wet	Wait until drier weather.
	Damaged seed tube	Check seed tubes for damage and replace as needed.
	Incorrect coulter depth setting	See coulter manual or set unit mounted coulter.
	Excessive or improper row unit down pressure spring setting	See “ <b>Down-Pressure Adjustment</b> ” on page 47.
	Rough planting conditions	Rework the field.
	Seed firmer not in place and set to correct tension	See “ <b>Keeton® Seed Firmer</b> ” on page 54.
<b>Some large singulated seeds are not accurate.</b>	Incorrect speed calibration, Sensor Constant, or Gear Ratio setup	Check and correct speed calibration, Sensor Constant, and Gear Ratio setup.

**Seed Population Too Low**

Problem	Cause	Solution
<b>Overall low population.</b>	Incorrect seed rate	Check seed rate charts.
	Incorrect ground drive transmission or range sprockets used	Check transmission sprocket or range sprocket tooth counts and driving/driven locations.
	Empty cells in the seed disk due to insufficient pressure	Increase controlled air to meter (page 35).
	Empty cells in the seed disk due to sticky seed treatments not allowing seed to rapidly fill the cells	Increase seed lubricant. See “ <b>Seed Lubricants</b> ” on page 38.
	Empty cells in the seed disk due to rough field conditions causing seeds to fall from the disk	Decrease field speed or increase air pressure in the meter.
	Empty cells in the seed disk due to seed pool too low and seeds not filling every cell in the seed disk	Open the seed inlet gate one notch.
	Empty cells in the seed disk due to disk speed too high and cells not filling	Decrease field speed or change to a higher cell count disk.
	Empty cells in the seed disk due to tufted brush too aggressive	Check for matted, stuck together fibers on brush. Wash, scrape, clean, or replace as needed.
	Empty cells in the seed disk due to seed too big for the cell	Select correct seed disk for seed size.
	Seeds are not falling from the seed disk and get carried past drop zone. Static electricity can cause small, lightweight seeds to cling to the cell and not fall out	The graphite component of Ezee Glide Plus addresses this issue. Increase the amount of Ezee Glide Plus and/or more thoroughly mix the lubricant into the seed.
	Air pressure too low, as confirmed by gauge	Increase fan speed or reduce baffle setting.

Problem	Cause	Solution
<b>Overall low population, continued.</b>	Air pressure too low, but gauge reading is within range or reading high	Compare the air pressure reported on the console to the mechanical gauge. If they do not match: <ul style="list-style-type: none"> <li>● Inspect the sample lines from the row units up to the sensor chamber for leaks.</li> <li>● Re-zero the air pressure with the fan off.</li> </ul>
	Bulk hopper planters - not enough air for seed delivery	Increase seed delivery fan speed.
	Inadequate contact wheel spring pressure	Check for correct spring and gap setting (page 44).
	Tire pressure in contact wheel incorrect	Check for correct tire air pressure. See <b>"Tire Information"</b> on page 118.
	Excess field speed	Plant within speed ranges from seed rate charts. See Material Rate manual.
	Improper gap on speed sensor	Check speed sensor on planter (page 15). Adjust as needed.
	Incorrect speed sensor constant	Perform speed calibration, see the console manual.
<b>Low population, one wing.</b>	Skipping chain from the drive to the wing	Check chain slack. Replace worn chain.
	Incorrectly adjusted drive dog on split shafts is slipping	Adjust drive dog on shaft.
<b>Low population, single row.</b>	Seed inlet gate opening too wide, interfering with meter pressurization	Adjust the gate to lower setting.
	Seed inlet gate opening too narrow, starving the meter of seed (low seed pool)	Adjust the gate to higher setting.
	Meter starvation due to bridging at the gate	Readjust for gate bridging (page 78). If seed is treated, increase seed lubricant. See <b>"Seed Lubricants"</b> on page 38.
	Skips due to low meter pressurization at one or several rows	Check gate setting. Check for excess wear on the seed drop brush. Check for loose or leaking pressure hose.
	Incorrect seed disk on one row	Install correct seed disk. See Material Rate manual for seed charts.
	Chain skipping at one row	Check for worn chain, worn idlers, and low chain slack.
	Skips due to debris in disk cells	Remove rain covers, inspect, and clean out disks.
	Seed sensor not able to count all seeds	Clean out seed tube.
	Seed tube plugged	Raise planter, expose bottom of seed tube and clean out.
<b>Low or erratic seed flow.</b>	Seed meter plugged due to operating with fan shut off or pressure too low	Close seed inlet gates. Clean out meters. Set fan for correct pressure. Resume planting.

**Seed Population Too High**

<b>Problem</b>	<b>Cause</b>	<b>Solution</b>
<b>Overall high population.</b>	Incorrect seed rate	Check seed rate charts.
	Incorrect ground drive transmission or range sprockets used	Check transmission sprocket or range sprocket selections and driving/driven locations.
	Two seeds per cell in the seed disk due to excess meter pressurization	Decrease the controlled air to the meter. See <b>"Fan Adjustment"</b> on page 35.
	Two seeds per cell in the seed disk due to cells too large for the seed	Select a disk with smaller cells.
	Air meter pressure too high due to pressure sensor not zeroed properly	Re-zero air pressure with fan off. Verify displayed pressure reads 0.00.
	Air pressure too high, but gauge is within range or reading low	Compare the air pressure reported on the console to the mechanical gauge. If they do not match: <ul style="list-style-type: none"> <li>● Inspect sample lines from row units up to sensor chamber for leaks.</li> <li>● Re-zero air pressure with fan off.</li> </ul>
	False alarms or actual seed rate errors due to console setup with incorrect row count, spacing, or active rows	Review planter configuration and console setup.
	Incorrect disk cell count	Replace seed disks with correct disks, or reset rate for current disks, if within range.
	Improper gap on speed sensor	Check speed sensor (page 15). An improper gap can cause erratic speed signal causing the console to falsely report an improper planting rate.
	Incorrect speed sensor constant	Perform speed calibration, see the console manual.
	Doubles due to incorrect disk for crop or seed size	Use the recommended disk for crop and seed size. See Material Rate manual for seed charts.
Sticky seeds from excess seed treatment	Increase seed lubricant. See <b>"Seed Lubricants"</b> on page 38.	
<b>High population, single row.</b>	Excess meter pressurization causing doubles	Check seed inlet gate. See <b>"Seed Inlet Gate Adjustment"</b> on page 41.
	Worn tufted brush allowing doubles	Replace worn brush.
	Worn seed-drop brush and/or strip brushes allowing excess seed to pass	Replace worn brushes.
	Incorrect seed disk with higher cell count	Install correct disk. See Material Rate manual for seed charts.

**Seed Delivery Problems - Bulk Seed**

Problem	Cause	Solution
<b>Single row does not fill or keep up with other rows.</b>	Drop tube to meter is too long causing seed to pool and plug hose	Shorten hose length while the planter is raised and the row units lowered. This will ensure the hose is not too short.
	Debris in seed at air box or in seed hose	Check for debris and clean as needed.
<b>Multiple rows fail for lack of seed.</b>	Fan speed too high or too low	Check and adjust fan speed. See " <b>Fan Adjustment</b> " on page 35.
	Out of seed	Add seed.
<b>Single or multiple hoses plugging just ahead of air box.</b>	Fan speed too high or too low	Check and adjust fan speed. See " <b>Fan Adjustment</b> " on page 35.
	Possible air leak	Check for air leak downstream between the air box and top of meter.
<b>All rows fail.</b>	Lack of seed	Fan speed too high. Adjust fan speed. See " <b>Fan Adjustment</b> " on page 35.
	Did not perform <i>Fill Disk</i> operation	Perform <i>Fill Disk</i> operation. Extremely high populations may require slightly reduced field speed.
<b>1, 2, 3, or more outlets fail</b> - Outlets can be side-by-side or random. Plugging may also move from one outlet to another.	Foreign matter in seed chamber in bottom of air box	Clean out seed chamber.
<b>Little or no seed to several rows with heavily treated seed.</b>	Seed treatment sticky	Add Ezee Glide Plus to seed to dry out seed treatment. See " <b>Seed Lubricants</b> " on page 38.
	Treatment mixed unevenly and plugging outlets	Clean out seed and re-mix.

**■ Planter Troubleshooting**

Problem	Cause	Solution
<b>Planter does not fold or unfold fully.</b>	Air in lines	Rephase hydraulic cylinder. See " <b>Unfolding</b> " on page 23.
	AUX selector valve set to AUX	Set valve to MARKERS. See " <b>Rear Auxiliary Hydraulics (Option)</b> " on page 17.
<b>Row unit disks not turning freely.</b>	Row unit plugged with dirt	Clean row unit.
	Planting conditions too wet	Wait until drier weather.
	Incorrect side depth wheel adjustment	Adjust side depth wheel. See " <b>Planter Leveling</b> " on page 15.
	Failed disk bearings	Replace disk bearings.
	Bent or twisted row unit frame	Replace row unit frame.
	Partially plugged seed tube	Lift up planter, expose bottom of seed tube and clean out.

Problem	Cause	Solution
<b>Press wheel or row units plugging.</b>	Planting conditions too wet	Wait until drier weather.
	Too much pressure on row units	Reduce down pressure on row units. See <b>“Down-Pressure Adjustment”</b> on page 47.
	Coulters set too deep, bringing up excess dirt and moisture	Check coulter adjustment.
	Planter not set to run level from front to rear	Check tongue height. See <b>“Planter Leveling”</b> on page 15.
	Backed up with planter in the ground	Clean out and check for damage.
	Failed disk bearings	Replace disk bearings.
	Disks are worn	Replace disks.
<b>Press wheel or row units plugging, continued.</b>	Scraper worn or damaged. Side depth wheels not set correctly	Adjust side depth wheels. See <b>“Side Depth Wheel Adjustments”</b> on page 49.
<b>Press wheels not compacting soil as desired.</b>	Incorrect spring handle setting	Correct spring handle setting. See <b>“Press Wheel Adjustments”</b> on page 51.
	Insufficient row unit down-force	Adjust row unit down-force See <b>“Down-Pressure Adjustment”</b> on page 47.
	Use of incorrectly shaped tire for conditions	Wedge shaped wheels work best on narrow spacings and in wet conditions. Round edge wheels work best in wider row spacings and drier conditions.
	Planter not level front to rear	Check tongue height. See <b>“Planter Leveling”</b> on page 15.
	Wheel stagger needs adjustment for conditions	Adjust press wheel stagger. See <b>“Press Wheel Stagger”</b> on page 51.
	Too wet or cloddy	Wait until drier weather or rework ground.
<b>Marker functioning improperly, or not at all.</b>	Marker switch not set correctly on rear aux hydraulic selector valve	Left or right not selected. Set tractor remote circuit to Neutral or Float before operating switch.
	Markers not raised or lowered fully to cycle sequencing valve	Fully raise and lower markers.
	Console not set to Field operation	Set console to Field operation.
	Air or oil leaks in hose fittings or connections	Check all hose fittings and connections for air or oil leaks.
	Low tractor hydraulic oil level	Check tractor hydraulic oil level.
	Loose or missing bolts or fasteners	Check all bolts and fasteners.
<b>Marker disk does not mark.</b>	Marker folding linkage does not have enough slack to allow marker disk to drop into field depressions	Maximum down float should be limited by slot at rod end of marker cylinder.
	Disk angle too straight for soil conditions	Reverse marker disk to pull or throw dirt.

## ■ Fertilizer Troubleshooting

Problem	Cause	Solution
<b>No fertilizer flow</b>	Hydraulic driven pump (option) not engaged	Engage pump.
	Various possible pump issues	Refer to pump manual.
	Tank and/or pump valves closed	Check that tank and pump valves are open (page 55)
	Chain missing at one or more drive stages	Check all chains from ground drive to pump (page 58).
	Tank plugged	Dilute or clean out any material clogging discharge port (page 70).
	Strainer plugged	Close all valves. Inspect strainer. Clean screen as needed. Switch to a larger screen size if materials clog strainer rapidly and large size orifices are in use.
	Pump setting at or near zero	Recommended pump adjuster settings are in the range 2 to 10. See Material Rate manual.
	Material run-out	Check tank level.
<b>Low rate</b>	Fertilizer transmission in low range when high range was intended	Change sprockets. See Material Rate manual.
	Various possible pump issues	Refer to pump manuals.
<b>Low pressure at desired rate</b>	Orifice size too large	Choose alternate orifice plate size. See Material Rate manual.
	Orifices correct plate size, but holes are enlarged from use	Replace orifice plates. Discard worn plates.
	Rate may actually be low	Check fertilizer drive sprockets.
<b>Uneven flow at desired rate</b>	One or more orifice plates plugged	Clean and reinstall orifice plates. Check that material is correct consistency for orifice size.
	Orifice plate sizes vary between rows	Check that all nozzles have the same size plates.
<b>Pressure unstable</b>	Strainer clogged	Close all valves. Inspect strainer. Clean screen as needed. Switch to a larger screen size if materials clog strainer rapidly and large size orifices are in use. See " <b>Liquid Fertilizer (Option)</b> " on page 55.
<b>Dumping at normal pressure</b>	Relief valve setting too low	Review relief valve setting. See Material Rate manual.

Problem	Cause	Solution
<b>High pressure at desired rate</b>	Orifice size too small	Review orifice sizing. If at recommended size, try the next large size. Charts are based on typical density/viscosity materials.
	Nozzles are plugged. Sedimentation, coagulation, particulates, and foreign matter can also cause unusually high pressure	Inspect low-flow rows or several nozzles. Clean plates. Consider smaller strainer screen size and/or large orifice plate size.
	Orifice plates upside down	Position plates with words facing outlet. Orifice port holes are not symmetrical, and at smaller sizes this can cause slightly higher back-pressure with denser materials.
<b>Very high flow</b>	Fertilizer transmission in high range instead of low range	Change sprockets. See Material Rate manual.
	Possible pump issues	See pump manual.
<b>Pump leaks</b>	Possible pump issues	See pump manual.
<b>Pump oil consumption</b>	Pump seals or o-ring	See pump manual.
<b>Noisy pump</b>	Crankcase components worn	See pump manual.

### ■ Topcon Console Troubleshooting

Problem	Cause	Solution
<b>Console does not power on</b>	Electrical harnesses are not connected.	Make electrical harness connections.
	Fuse has blown.	Replace fuse. See “ <b>Topcon XD and XD-Plus</b> ” on page 117 for fuse diagram.

## Options

### ■ Rear Auxiliary Hydraulics

When the planter is not in motion, auxiliary hydraulics enable the marker hydraulic circuit to drive other equipment, such as a seed auger.



Description	Part Number
Auxiliary Rear Hydraulics	411-537A

### ■ Swath Command

Swath Command provides automatic section control. The two standard manually operated section clutches are replaced by individual row clutches. These row clutches are connected in pairs to the console CANBUS providing 6 or 8 sections under computer control.

Sections are automatically disabled when overrunning a previously planted area, or when entering a non-planting area as defined by a pre-loaded instruction.

The kit does not include, but will require, a GPS source option.

Description	Part Number
12-Row Hopper Tru-Count Swath Command	402-710A 402-729A
16-Row Hopper Tru-Count Swath Command	402-738A 402-739A
AG-372 DGPS Receiver Kit	823-430C
Passcode, AG-372 Upgrade DGPS to OmniSTAR XP/HP (does not include subscription service or RTK radio, dealer installed)	823-431C
Passcode, AG-372 Upgrade OmniSTAR XP/HP to RTK	823-429C
RTK Radio, 900 Mhz	823-426C

### ■ Topcon Console System

Topcon console systems provides powerful functionality for precision machine control. Your console will come configured with software for machine control. Refer to the Topcon console operator manual for installation instructions.



Description	Part Number
XD-Plus Console Kit	194-468A
XD Console Kit	194-467A
GPS Receiver and Mount*	194-472S
ISOBUS Analog Camera**	411-861A
Adapter Harness for XD-Plus/XD***	843-411C

\* GPS is customer-provisioned.

\*\* Up to three cameras may be used with XD-Plus console. One camera may be used with XD console.

\*\*\* One adapter harness is required for each camera.

### ■ Dickey-john PM300 with Switch Box

Dickey-john PM300 Seed Monitoring System with Switch Box will report the following elements:

- Ground speed,
- up to two hopper levels, and
- seed rate at each row unit seed tube.

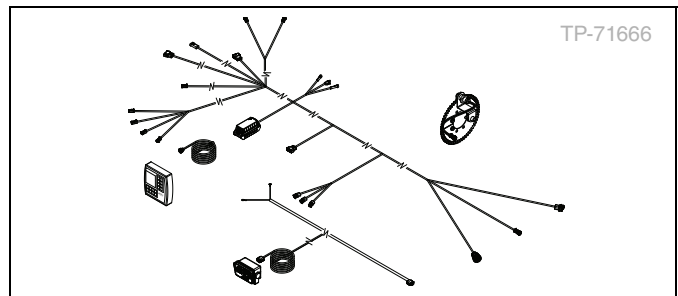



Medium and large seeds are individually counted with high accuracy. Small seeds, such as Milo, may be more difficult to sense, and instead, the seed monitoring system will indicate seed blockage.

The standard magnetic pickup at the ground drive allows the seed monitoring system to calculate and report seed population after the seed monitoring system has been configured for the preferred material rates. The switch box will perform the following operations:

- planter raising/lowering,
- wing gauge wheels raising/lowering,
- center frame only raising/lowering
- planter folding/unfolding,
- independent electric clutch control for each side of the planter, if installed, and
- marker raising/lowering, if installed.

The kit does not include, but will require, fasteners for the in-cab mounting brackets.

Description	Part Number
12-Row PM300 Monitor w/Switch Box	431-007A
16-Row PM300 Monitor w/Switch Box	431-008A

**■ Bulk Seed Scale Option**

A weighing system is available as an option for bulk hopper planters.

Description	Part Number
Bulk Seed Scale Option	403-848A

**■ Bulk Hopper Seed Sensor**

Up to two in-hopper seed sensors may be installed on planters configured with the bulk hoppers. Hopper level information will be displayed on the IntelliAg ISO6 compatible in-cab console. Order one sensor per bulk hopper.

Description	Part Number
Bulk Hopper Seed Level Sensor	833-235C

**■ Weight Transfer System**

For challenging conditions, a weight transfer kit is available to achieve consistent planting depth while keeping the wings level with the center section.

Description	Part Number
Weight Transfer System - 12-Row	411-936A
Weight Transfer System - 16-Row	411-853A

**■ Rear Hitch Assembly**

The rear hitch assembly option has a 25000 lb (11340 kg) gross weight maximum allowable load and 1000 lb (454 kg) tongue weight. A trailer light harness is included.

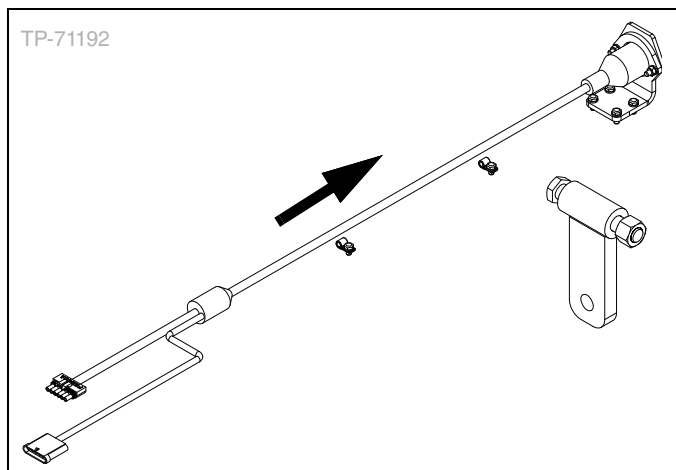

Description	Part Number
Rear Hitch Assembly	411-536A

**■ Keeton® Seed Firmer**

One one per opener.

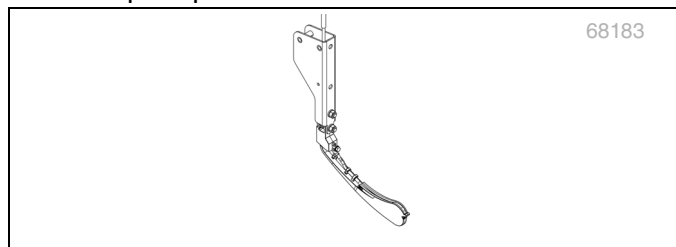

Description	Part Number
Keeton® Seed Firmer	890-840C

**■ Fertilizer System**

**Fertilizer Tanks**

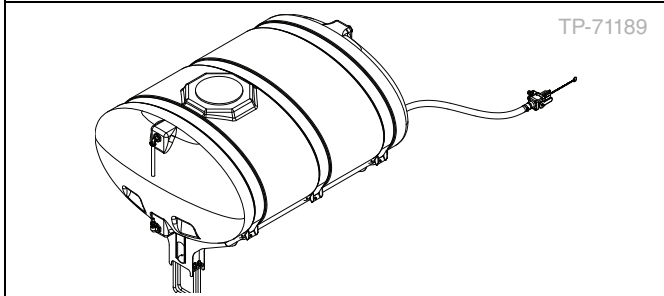
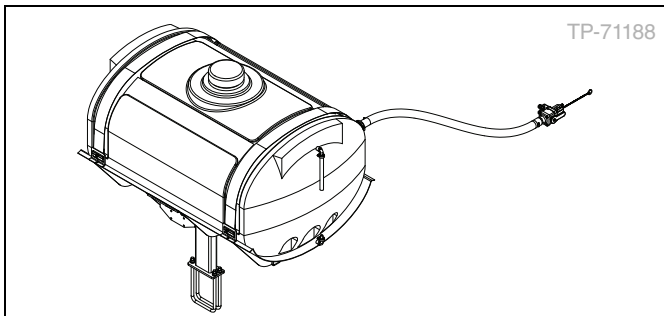

Description	Part Number
Bulk Hopper - Fertilizer Tank Option	417-057A
Row Hopper - Fertilizer Tank Option	417-691A

**Fertilizer Orifice Plates**

The manifold systems include size 28, 34, and 48 orifice plates. To order orifice plates, use the following part numbers. Order one per row unit.

Orifice Size	Part Number	Part Diameter	Port Area
20	832-052C	0.020 inch	0.20 mm <sup>2</sup>
28*	832-056C	0.028 inch	0.40 mm <sup>2</sup>
34*	832-053C	0.034 inch	0.59 mm <sup>2</sup>
48*	832-054C	0.048 inch	1.17 mm <sup>2</sup>
59	832-057C	0.059 inch	1.76 mm <sup>2</sup>
80	832-055C	0.080 inch	3.24 mm <sup>2</sup>
98	832-059C	0.098 inch	4.87 mm <sup>2</sup>

\*Sizes standard in many fertilizer bundles. Check your accessories before ordering.

**Fertilizer Dribblers**

Fertilizer dribblers apply liquid fertilizer slightly to the side of the closed furrow behind the press wheel. Dribblers are available in left-hand and right-hand

offsets, for use on twin rows. Order one dribbler per row.

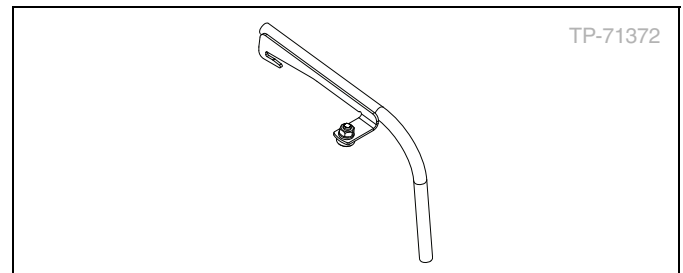

Description	Part Number
Right-Hand Fertilizer Dribbler	427-091A
Left-Hand Fertilizer Dribbler	427-090A

**Fertilizer Flow Sensor**

Fertilizer Flow Sensor will monitor liquid fertilizer flow.

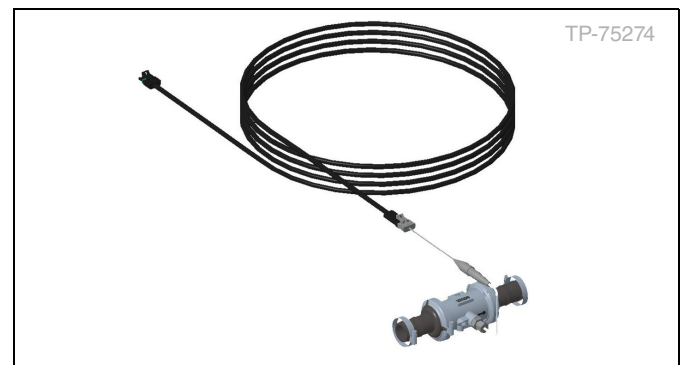

Description	Part Number
Fertilizer Flow Sensor	417-377A

**VeriFlow Nozzles**

To eliminate the need to change orifice plates, replace the standard nozzles with Spray Target VeriFlow nozzles. These nozzles contain a spring-loaded regulator that provides consistent back pressure over a wide range of rates and pressures. Great Plains offers two models of VeriFlow nozzles. Order one nozzle for each active boom clamp.



Description	Part Number
Nozzle Hi-VeriFlow 1 (0.25 to 2.8 gpm at 15 to 60 psi)	829-143C
Nozzle VeriFlow 1 (0.15 to 1.5 gpm at 15 to 60 psi)	829-144C

**VisaGage II (S/N E1008B-)**

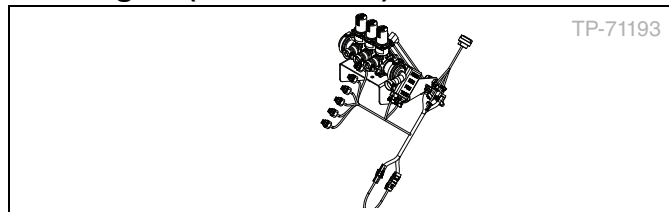

Description	Part Number
VisaGage II Fertilizer 3-Section Control System	427-084A

**VisaGage II (S/N E1009B+)**

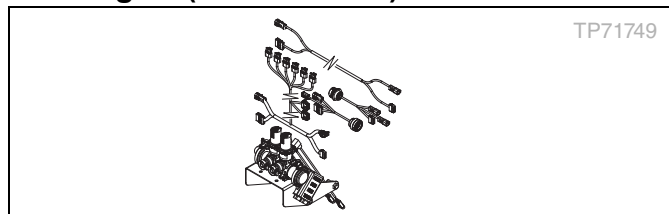

Description	Part Number
VisaGage II Fertilizer 2-Section Control System	427-108A

**VisaGage II (S/N E1009B+)**

The VisaGage II monitors flow rates for applying liquid fertilizer.

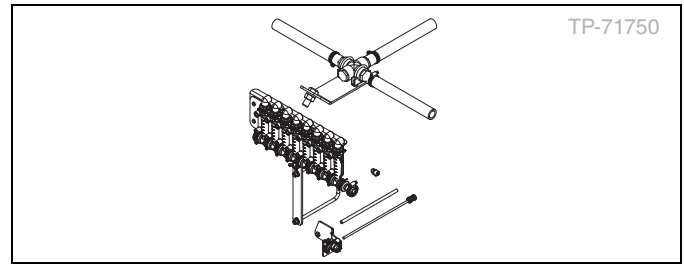

Description	Part Number
12-Row VisaGage II	427-070A
16-Row VisaGage II	427-043A

**Fertilizer Hydraulic Drive**

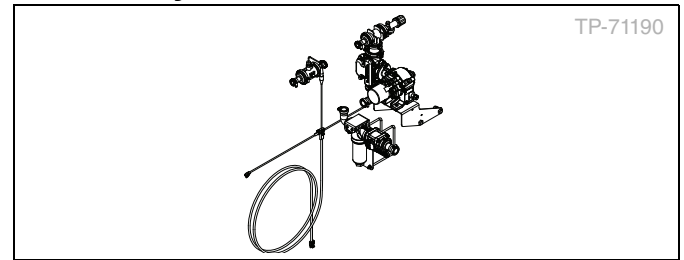

Description	Part Number
Hydraulic Drive Fertilizer	427-081A

**Fertilizer Ground Drive**

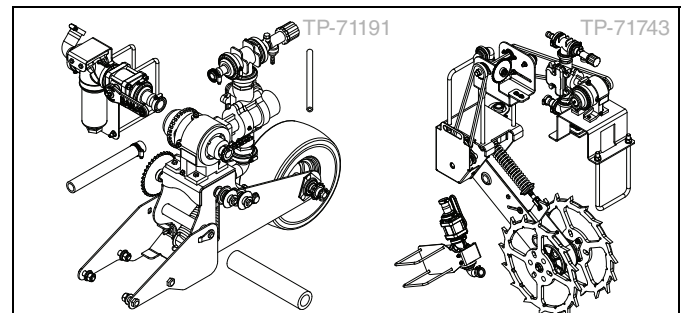

Description	Part Number
Fertilizer Ground Drive 12-Row (30 in)	427-044K
Fertilizer Ground Drive 16-Row (30 in)	
Fertilizer Ground Drive 12-Row (70 cm)	427-109A
Fertilizer Ground Drive 16-Row (70 cm)	

■ **Seed Lubricant**



Description	Part Number
Ezee Glide Plus Talc and Graphite Mix 5 gal (18.9 liter) container	821-069C
Fluency Powder case quantity	821-074C
Fluency Powder single 4.4 pound bucket	821-075C

■ **Unit Mount Row Cleaners**

**Unit Mount Row Cleaner (UMRC)**

UMRC is stand alone assembly that uses a unit mount.

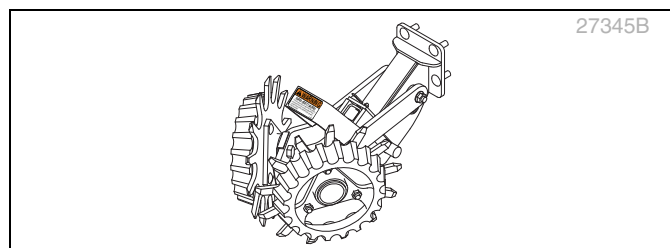

Description	Part Number (S/N E1024B-)	Part Number (S/N E1025B+)
Double Row Cleaners - 12-Row	207-126A	207-348A
Double Row Cleaners - 16-Row	207-113A	207-349A

**Unit Mount Coupler Row Cleaner**

UMC-RC uses a coupler disk mounting bracket, with or without a coupler disk.

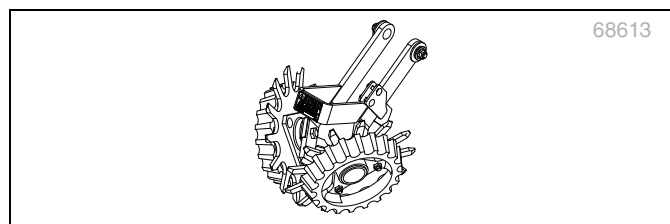

Description	Part Number (S/N E1024B-)	Part Number (E1025B+)
Double 30" Row Spacing 12-Row	207-130A	207-313A
Double 30" Row Spacing 16-Row	207-129A	207-315A

Description	Part Number (S/N E1024B-)	Part Number (E1025B+)
Double 70 cm Row Spacing 12-Row	207-321A	207-352A
Double 70 cm Row Spacing 16-Row	207-322A	207-353A

■ **Unit Mounted Disk Coulters**

Optional unit mount disk coulters are available with fluted or turbo blades.

Description	Part Number
Unit Mount Coulters Fluted - 12-Row	204-552A
Unit Mount Coulters Fluted - 16-Row	204-551A
Unit Mount Coulters Turbo - 12-Row	204-554A
Unit Mount Coulters Turbo - 16-Row	204-553A

**Coulters Blades**

Replacement and alternate coulters blades (quantity is one per row unit):

Description	Part Number
15 inch Turbo Coulters Blade	820-327C
15 inch Fluted Coulters Blade	820-331C

■ **Inside Disk Scrapers**

When planting in moist or sticky soils, the inside disk scraper is useful in preventing buildup that might impair opener disk performance.

The carbide scraper is spring loaded and requires no adjustment.

Description	Part Number
Inside Disk Scraper	122-278S

■ **Row Unit Press Wheels**

The base planter includes a choice of press wheels. Additional press wheels are available and may be field installed.

The part numbers are not listed here because available press wheels are often region specific. See your Great Plains dealer.

■ **Side Depth Wheel Scrapers**

When planting in moist or sticky soils, the side depth wheel scrapers are useful in preventing buildup that might result in shallow planting.

The scrapers mount on the bottom rear of the depth wheel arm, using the existing bolt and lock washer.

The slot in the scraper is long enough to clear the lower grease fitting and allow adjustment as the wheel and scraper wear.

Order one per row.

Description	Part Number
4-inch Depth Wheel Scraper	404-825A

**Seed Meter Clean-Out Container**

One seed meter clean-out container is provided with the planter and located at the left end of the planter. Use the following information to order an additional or a replacement container.

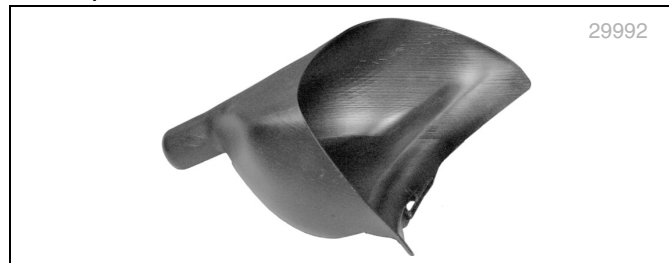

Description	Part Number
Air Meter Clean Out Funnel	817-811C

**Seed Tube Brush**

One brush is provided with the planter. Use the following to order an additional or a replacement brush.



Description	Part Number
Seed Tube Cleaner Brush	891-259C

**Seed Meter Disks**

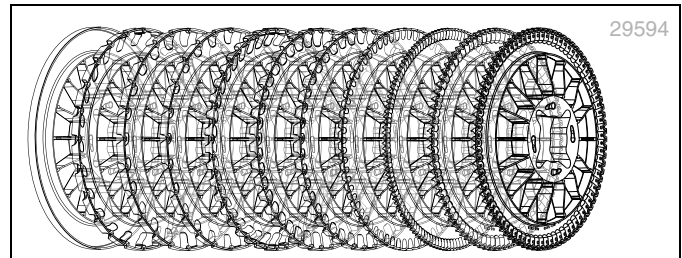

Description	Part Number
Blank Disk (for row shut-off)	817-841C
Canola, 250 Cell	817-991C
Canola, 150 Cell	837-148C
Corn, 24 Cell (Large, Flat)	817-836C
Corn, 24 Cell (Large, Round)	837-602C
Corn, 24 Cell (Medium)	837-126C
Corn, 24 Cell (Small, Round, or Flat)	817-795C
Corn Disk Kit, 24 Cell - includes 1 Round-Small, -Medium, -Large, and 1 Flat-Large	403-554A
Corn, 40 Cell (Large, Flat)	817-838C
Corn, 40 Cell (Large, Round)	837-603C
Corn, 40 Cell (Medium)	837-127C
Corn, 40 Cell (Small, Round, or Flat)	817-797C
Corn Disk Kit, 40 Cell - includes 1 Round-Small, -Medium, -Large, and 1 Flat-Large	403-555A
Cotton, 60 Cell	817-857C
Edible Bean, 56 Cell (Large)	817-967C
Edible Bean, 60 Cell (Medium)	837-065C
Industrial Hemp, 5 Cell	834-364C
Industrial Hemp, 30 Cell	837-386C
Hill Drop Cotton, 12 Cell	837-186C
Milo and Pelletized Sugar Beet, 30 Cell	837-057C
Milo and Pelletized Sugar Beet, 65 Cell	817-849C
Milo and Pelletized Sugar Beet, 130 Cell	817-800C
Soybeans, 60 Cell (Small)	837-306C
Soybeans, 84 Cell (Medium)	817-798C
Soybeans, 168 Cell (Large)	403-551D
Sunflower, 60 Cell (Small)	837-234C
Sunflower, 60 Cell (Medium)	837-235C
Sunflower, 24 Cell (Large)	817-851C

---

Description	Part Number
Wheat/Rice, 84 Cell - volumetric	817-867C

### ■ SureForce Hydraulic Option



With SureForce installed on a machine, row depth is monitored and adjusted through hydraulic pressure and a gauge wheel sensor system. The system can apply up to 250 pounds of uplift and 650 pounds of down force.

The system allows for Individual Row Control (IRC).

For more information on SureForce, write or e-mail Ag Leader at:

**2202 South Riverside Drive  
Ames, Iowa 50010  
info@agleader.com**

For immediate customer assistance with a SureForce system, call **515-735-7000**.

# Specifications

-1230 Models	PL5700-CH-1230	PL5700-IH-1230	PL5700-CB-1230	PL5700-IB-1230
Row count	12			
Row spacing	30 inch (76.2 cm)			
Minimum tractor requirement	140 hp (104 kw)			
Hitch	Standard two-point hitch, optional hydraulic hitch			
Hydraulic circuit	Closed-center with 3 remotes plus additional remotes for optional: Wing Weight Transfer System Hydraulic Seed Drive Hydraulic Liquid Fertilizer Drive		Closed-center with 4 remotes plus additional remotes for optional: Wing Weight Transfer System Hydraulic Seed Drive Hydraulic Liquid Fertilizer Drive	
Tire size	VF295/75R22.5 AD2			
Working width	30 ft (9.1 m)			
Working length	19 ft 9 in (6 m)			
Working height	8 ft 3 in (2.5 m)		9 ft 2 in (2.8 m)	
Transport width	1.6 bu (56 liters) hopper - 11 ft 6 in (3.5 m) 3.0 bu (105 liters) hopper - 13 ft (4 m)		11 ft 11 in (3.6 m)	
Transport length	29 ft 9 in (9 m)			
Transport height, base <sup>a</sup>	8 ft (2.4 m)		11 ft 5 in (3.5 m)	
Transport height, w/ markers	10 ft 6 in (3.2 m)			
Transport clearance	19.6 in (50 cm)			
Field length	20 ft 1 in (6.1 m)			
Weight, base <sup>a</sup>	10 770 lb (4890 kg)	10 220 lb (4640 kg)	12 150 lb (5510 kg)	11 610 lb (5260 kg)
Weight, empty minimum <sup>b</sup>	11 860 lb (5380 kg)	11 310 lb (5130 kg)	13 230 lb (6000 kg)	12 690 lb (5760 kg)
Weight, full minimum <sup>c</sup>	17 860 lb (8100 kg)	17 310 lb (7850 kg)	19 230 lb (8720 kg)	18690 lb (8480 kg)
Weight, empty maximum <sup>d</sup>	14 510 lb (6580 kg)	13 860 lb (6290 kg)	15 360 lb (6970 kg)	14 720 lb (6680 kg)
Weight, full maximum <sup>e</sup>	23 990 lb (10 880 kg)	23 340 lb (10 590 kg)	24 840 lb (11 270 kg)	24 200 lb (10 980 kg)
Seed capacity	Per row - 3 bu (105 liter) hopper Total - 36 bu (1260 liter) Per row - 1.6 bu (56 liter) hopper Total - 19.2 bu (672 liter)		Per seed bulk hopper - 50 bu (1760 liter) Total - 100 bu (3520 liter)	
Fertilizer capacity	600 gal (2271 liter)		400 gal (1514 liter)	
Opener Down Pressure	320 to 535 lbs (145 to 243 kg)			
Opener Travel (Up - Down)	10 in (25.4 cm)			
Opener Depth Range	0 to 3.5 in (0 to 9 cm)			

- a. Base configuration is row hoppers (1.6 bu) or bulk hoppers, without markers, fertilizer, coulters, and row cleaners.
- b. Minimum configuration is row hoppers (1.6 bu) or bulk hoppers, with markers, and without fertilizer, coulters, and row cleaners.
- c. Full minimum configuration with 60 lb/bu (0.77 kg/liter) seed.
- d. Maximum configuration is row hoppers (3.0 bu) or bulk hoppers, markers, fertilizer, and unit mount row cleaners.
- e. Full maximum configuration with 60 lb/bu (0.77 kg/liter) seed and 1.04 kg/liter (8.7 lb/gal) fertilizer.

-1630 Models	PL5700-CH-1630	PL5700-IH-1630	PL5700-CB-1630	PL5700-IB-1630
Row count	16			
Row spacing	30 inch (76.2 cm)			
Minimum tractor requirement	190 hp (142 kw)			
Hitch	Standard two-point hitch, optional hydraulic hitch			
Hydraulic circuit	Closed-center with 3 remotes plus additional remotes for optional: Wing Weight Transfer System Hydraulic Seed Drive Hydraulic Liquid Fertilizer Drive		Closed-center with 4 remotes plus additional remotes for optional: Wing Weight Transfer System Hydraulic Seed Drive Hydraulic Liquid Fertilizer Drive	
Tire size	VF295/75R22.5 AD2			
Working width	40 ft (12.2 m)			
Working length	23 ft 10 in (7.3 m)			
Working height	8 ft 3 in (2.5 m)		9 ft 2 in (2.8 m)	
Transport width	1.6 bu (56 liters) hopper - 11 ft 6 in (3.5m) 3.0 bu (105 liters) hopper - 13 ft (4 m)		11 ft 11 in (3.6 m)	
Transport length	34 ft 4 in (10.5 m)			
Transport height, base <sup>a</sup>	8 ft (2.4 m)		11 ft 5 in (3.5 m)	
Transport height, w/ markers	3.2 m (10 ft 6 in)		11 ft 5 in (3.5 m)	
Transport clearance	19.6 in (50 cm)			
Field length	23 ft 10 in (7.3 m)			
Weight, base <sup>a</sup>	16300 lb (7390 kg)	15 630 lb (7090 kg)	17 190 lb (7800 kg)	16 670 lb (7560 kg)
Weight, empty minimum <sup>b</sup>	17 760 lb (8060 kg)	17 090 lb (7750 kg)	18 660 lb (8460 kg)	18 130 lb (8220 kg)
Weight, full minimum <sup>c</sup>	23 760 lb (10 780 kg)	23 090 lb (10 740 kg)	24 660 lb (11 180 kg)	24 130 lb (10 950 kg)
Weight, empty maximum <sup>d</sup>	20 660 lb (9370 kg)	19 810 lb (8980 kg)	20 906 lb (9510 kg)	20 340 lb (9230 kg)
Weight, full maximum <sup>e</sup>	30 140 lb (13 670 kg)	29 290 lb (13 280 kg)	30 440 lb (13 810 kg)	29 820 lb (13 530 kg)
Seed capacity	Per row - 3 bu (105 liters) hopper Total - 48 bu (1692 liters) Per row - 1.6 bu (56 liters) hopper Total - 25.6 bu (902 liters)		Per seed bulk hopper - 1760 liters (50 bu) Total - 3520 liters (100 bu)	
Fertilizer capacity	600 gal (2271 liters)		400 gal (1514 liters)	
Opener Down Pressure	320 to 535 lbs (145 to 243 kg)			
Opener Travel (Up - Down)	10 in (25.4 cm)			
Opener Depth Range	0 to 3.5 in (0 to 9 cm)			

- a. Base configuration is row hoppers (1.6 bu) or bulk hopper, without markers, fertilizer, coulters, and row cleaners.
- b. Minimum configuration is row hoppers (1.6 bu) or bulk hopper, with markers, and without fertilizer, coulters, and row cleaners.
- c. Full minimum configuration with 60 lb/bu (0.77 kg/liter) seed.
- d. Maximum configuration is row hoppers (3.0 bu) or bulk hopper, with markers, fertilizer, coulters, and unit mount row cleaners.
- e. Full maximum configuration with 60 lb/bu (0.77 kg/liter) seed and 1.04 kg/liter (8.7 lb/gal) fertilizer.

-1270 Models	PL5700-CH-1270	PL5700-IH-1270	PL5700-CB-1270	PL5700-IB-1270
Row count	12			
Row spacing	70 cm (27.6 in)			
Minimum tractor requirement	104 kw (140 hp)			
Hitch	Standard two-point hitch, optional hydraulic hitch			
Hydraulic circuit	Closed-center with 3 remotes plus additional remotes for optional: Wing Weight Transfer System Hydraulic Seed Drive Hydraulic Liquid Fertilizer Drive		Closed-center with 4 remotes plus additional remotes for optional: Wing Weight Transfer System Hydraulic Seed Drive Hydraulic Liquid Fertilizer Drive	
Tire size	VF295/75R22.5 AD2			
Working width	8.5 m (28.0 ft)			
Working length	6.0 m (19 ft 9 in)			
Working height, w/markers	2.5 m (8 ft 3 in)		2.8 m (9 ft 2 in)	
Transport width	56 liters (1.6 bu) hopper - 3.5 m (11 ft 6 in) 105 liters (3.0 bu hopper) - 4.0 m (13 ft)		11 ft 11 in (3.6 m)	
Transport length	9 m (29 ft 9 in)			
Transport height, base <sup>a</sup>	2.4 m (8.0 ft)		3.5 m (11 ft 5 in)	
Transport clearance	50 cm (19.6 in)			
Weight, base <sup>a</sup>	5110 kg (11266 lb)	4500 kg (9921 lb)	5730 kg (12633 lb)	5120 kg (11288 lb)
Weight, empty minimum <sup>b</sup>	5520 kg (12170 lb)	4910 kg (10825 lb)	6140 kg (13536 lb)	5540 kg (12214 lb)
Weight, full minimum <sup>c</sup>	8240 kg (18166 lb)	7630 kg (16821 lb)	8860 kg (19533 lb)	8360 kg (18431 lb)
Weight, empty maximum <sup>d</sup>	6940 kg (15300 lb)	6290 kg (13860 lb)	7330 kg (16160 lb)	6680 kg (14727 lb)
Weight, full maximum <sup>e</sup>	11240 kg (24780 lb)	10590 kg (23347 lb)	11630 kg (25640 lb)	10980 kg (24207 lb)
Seed capacity	Per row - 105 liters (3.0 bu hopper) hopper Total - 1260 liters (36.0 bu) Per row - 56 liters (1.6 bu) hopper Total - 677 liters (19.2 bu)		Per seed bulk hopper - 1760 liters (50.0 bu) Total - 3520 liters (100.0 bu)	
Fertilizer capacity	2271 liters (600 gal)		1514 liters (400 gal)	
Opener Down Pressure	145 to 243 kg (320 to 535 lbs)			
Opener Travel (Up - Down)	25.4 cm (10 in)			
Opener Depth Range	0 to 9 cm (0 to 3.5 in)			

- a. Base configuration is row hoppers 56 liters (1.6 bu) or bulk hoppers, without markers, fertilizer, coulters, and row cleaners.
- b. Minimum configuration is row hoppers 56 liters (1.6 bu) or bulk hoppers, with markers, and without fertilizer, coulters, and row cleaners.
- c. Full minimum configuration with 0.77 kg/liter (60 lb/bu) seed.
- d. Maximum configuration is hoppers 105 liters (3.0 bu) or bulk hoppers, with markers, fertilizer, and unit mount row cleaners.
- e. Full maximum configuration with 0.77 kg/liter (60 lb/bu) seed and 1.04 kg/liter (8.7 lb/gal) fertilizer.

-1670 Models	PL5700-CH-1670	PL5700-IH-1670	PL5700-CB-1670	PL5700-IB-1670
Row count	16			
Row spacing	70 cm (27.6 in)			
Minimum tractor requirement	142 kw (190 hp)			
Hitch	Standard two-point hitch, optional hydraulic hitch			
Hydraulic circuit	Closed-center with 3 remotes plus additional remotes for optional: Wing Weight Transfer System Hydraulic Seed Drive Hydraulic Liquid Fertilizer Drive		Closed-center with 4 remotes plus additional remotes for optional: Wing Weight Transfer System Hydraulic Seed Drive Hydraulic Liquid Fertilizer Drive	
Tire size	VF295/75R22.5 AD2			
Working width	11.25 m (36 ft 11 in)			
Working length	7.3 m (23 ft 10 in)			
Working height	2.5 m (8 ft 3 in)		2.8 m (9 ft 2 in)	
Transport width	56 liters (1.6 bu) hopper - 3.5 m (11 ft 6 in) 105 liters (3.0 bu hopper) - 4.0 m (13 ft)		11 ft 11 in (3.6 m)	
Transport length	10.5 m (34 ft 4 in)			
Transport height, base <sup>a</sup>	2.4 m (8 ft)		3.5 m (10 ft 5 in)	
Transport clearance	50 cm (19.6 in)			
Weight, base <sup>a</sup>	7630 kg (16820 lb)	6970 kg (15370 lb)	8040 kg (17730 lb)	7440 kg (16400 lb)
Weight, empty minimum <sup>b</sup>	8220 kg (18120 lb)	7550 kg (16650 lb)	8620 kg (19000 lb)	8020 kg (17680 lb)
Weight, full minimum <sup>c</sup>	10940 kg (24120 lb)	10270 kg (22640 lb)	11340 kg (25000 lb)	10750 kg (23700 lb)
Weight, empty maximum <sup>d</sup>	9750 kg (21500 lb)	9000 kg (19840 lb)	9890 kg (21800 lb)	9250 kg (20400 lb)
Weight, full maximum <sup>e</sup>	14050 kg (30980 lb)	13000 kg (29320 lb)	14190 kg (31280 lb)	13550 kg (29870 lb)
Seed capacity	Per row - 105 liters (3.0 bu hopper) hopper Total - 1260 liters (36.0 bu) Per row - 56 liters (1.6 bu) hopper Total - 677 liters (19.2 bu)		Per bulk hopper - 1760 liters (50.0 bu) Total - 3520 liters (100.0 bu)	
Fertilizer capacity	2271 liters (600 gal)		1514 liters (400 gal)	
Opener Down Pressure	145 to 243 kg (320 to 535 lbs)			
Opener Travel (Up - Down)	25.4 cm (10 in)			
Opener Depth Range	0 to 9 cm (0 to 3.5 in)			

- a. Base configuration is row hoppers (1.6 bu) or bulk hoppers, without markers, fertilizer, coulters, and row cleaners.
- b. Minimum configuration is row hoppers (1.6 bu) or bulk hoppers, with markers, and without fertilizer, coulters, and row cleaners.
- c. Full minimum configuration with 0.77 kg/liter (60 lb/bu) seed.
- d. Maximum configuration is row hoppers 105 liters (3.0 bu) or bulk hoppers, with markers, fertilizer, coulters, and unit mount row cleaners.
- e. Full maximum configuration with 0.77 kg/liter (60 lb/bu) seed and 1.04 kg/liter (8.7 lb/gal) fertilizer.

■ Transport Dimensions

Bulk Hopper Planters

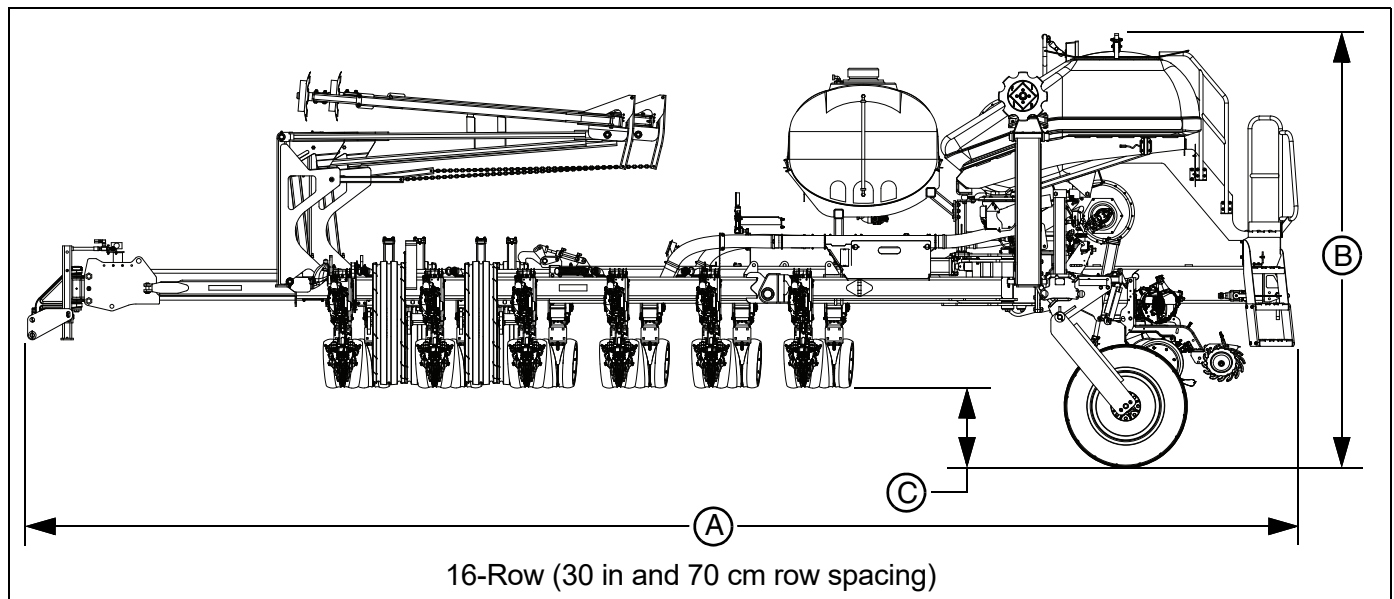
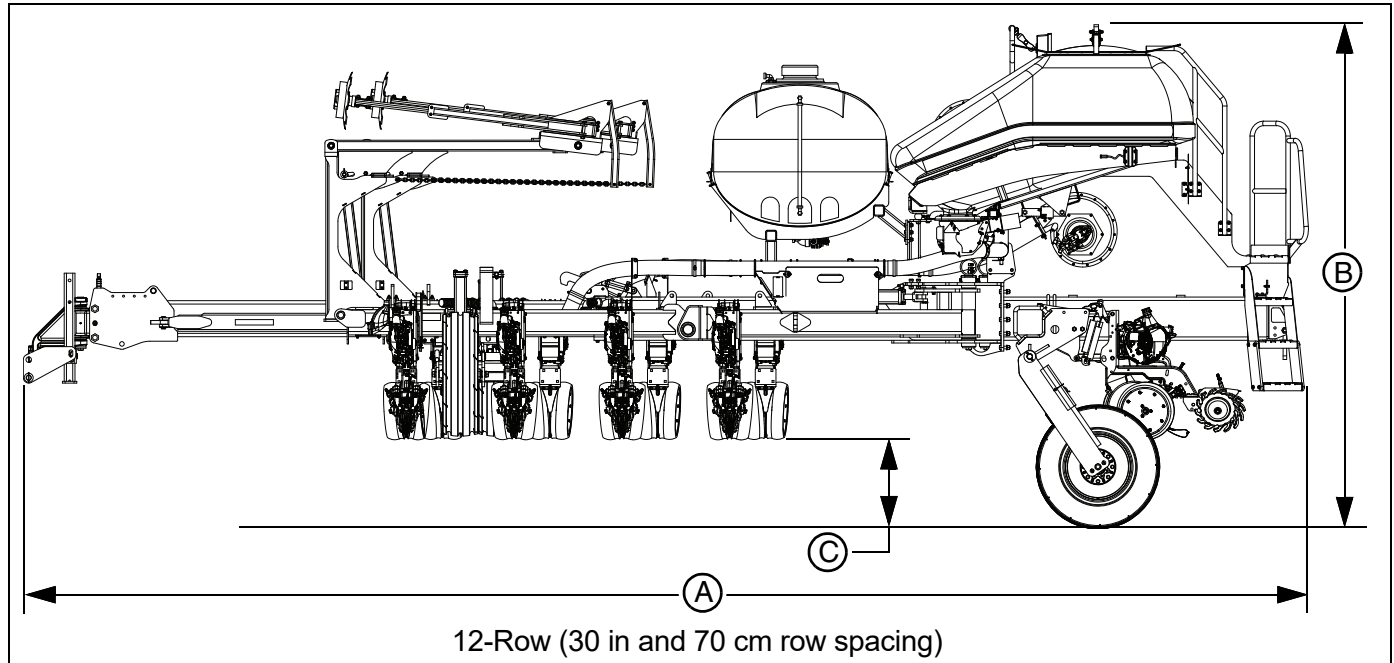

Callout	Description	Dimension	
		12-Row	16-Row
A	Transport Length	29 ft 9 in (9m)	34 ft 4 in (10.5 m)
B	Transport Height, Bulk Hopper	11 ft 5 in (3.5 m)	
C	Transport Clearance	19.6 in (50 cm)	

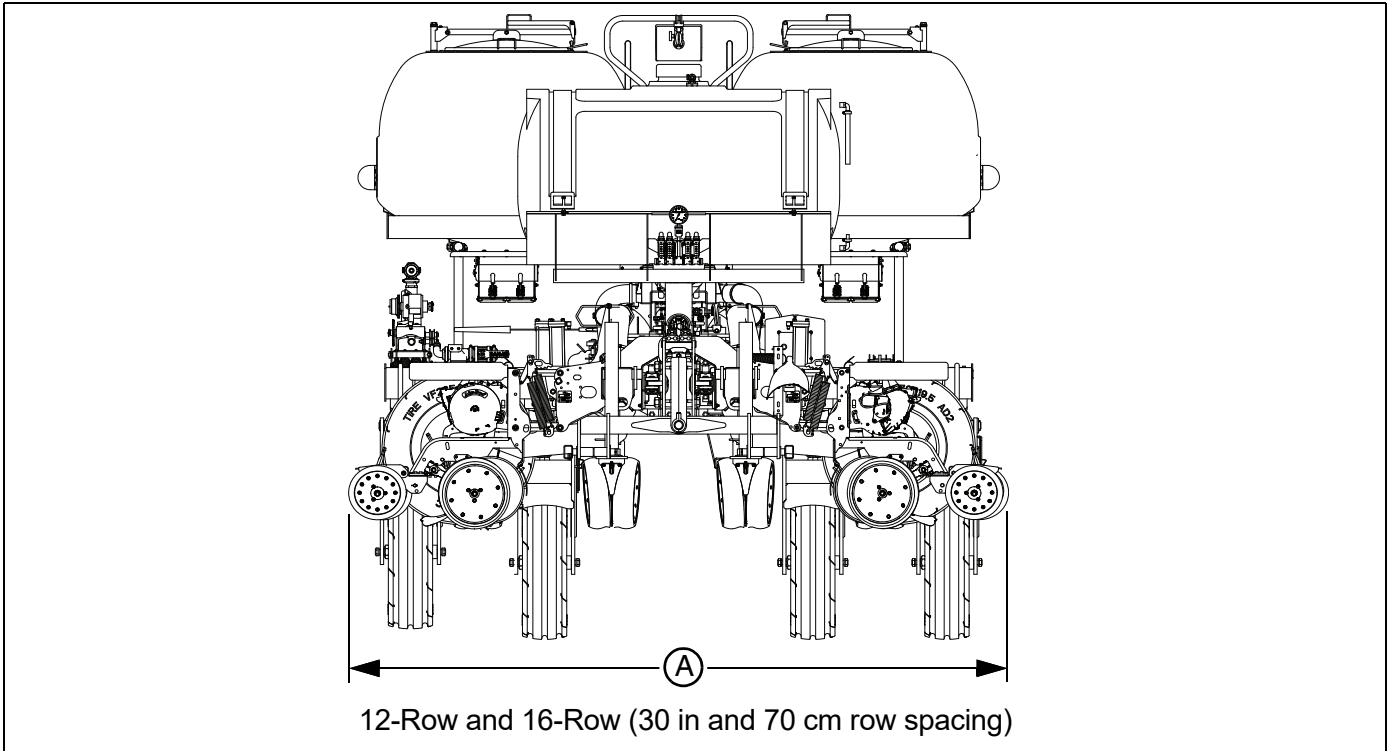

Callout	Description	Dimension
A	1.6 bushel hoppers	11 ft 11 in (3.6 m)
	3.0 bushel hoppers	13 ft (4 m)
	Bulk Hopper	11 ft 11 in (3.6 m)

Row Hopper Planters

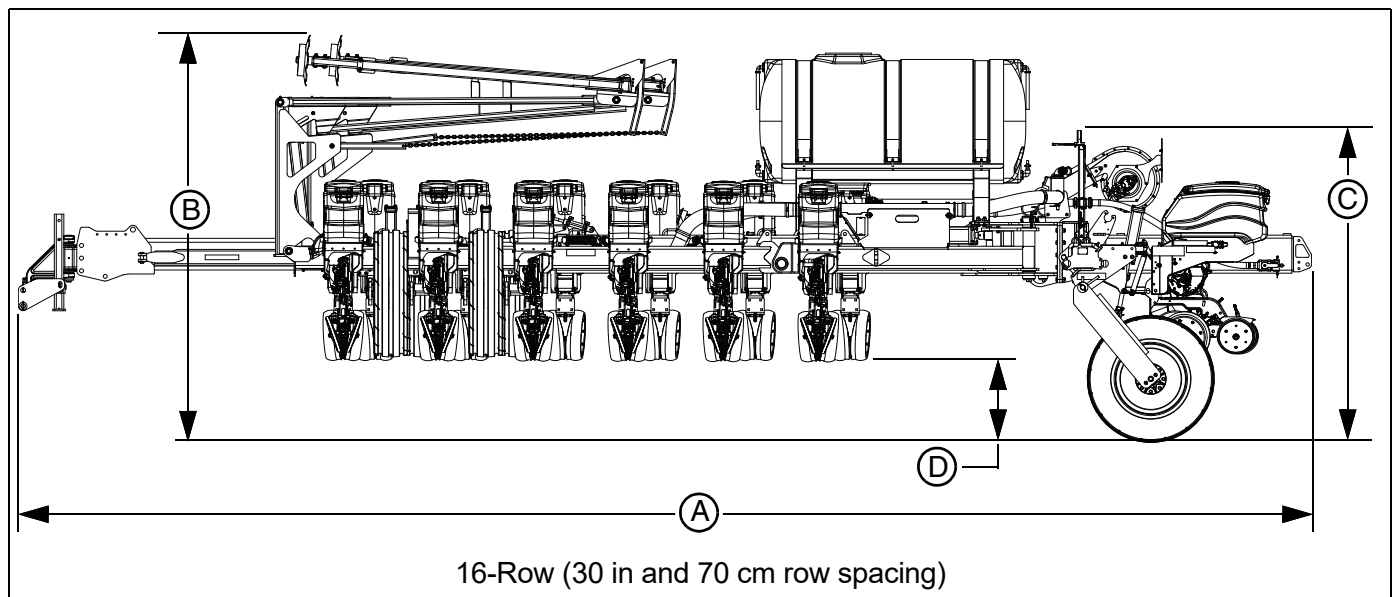
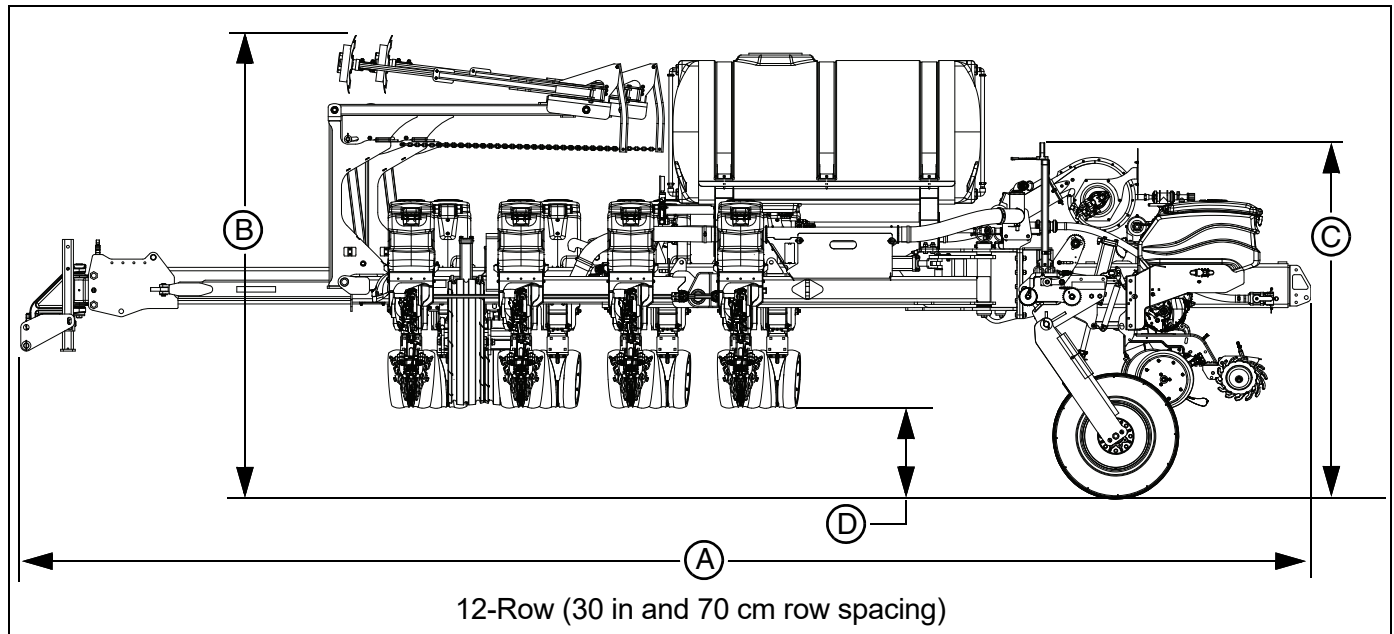

Callout	Description	Dimension	
		12-Row	16-Row
A	Transport Length	29 ft 9 in (9m)	34 ft 4 in (10.5 m)
B	Transport Height, Markers	10 ft 6 in (3.2 m)	
C	Transport Height, Hoppers	8 ft (2.4 m)	
D	Transport Clearance	19.6 in (50 cm)	

■ Field/Working Dimensions

12-Row Planters

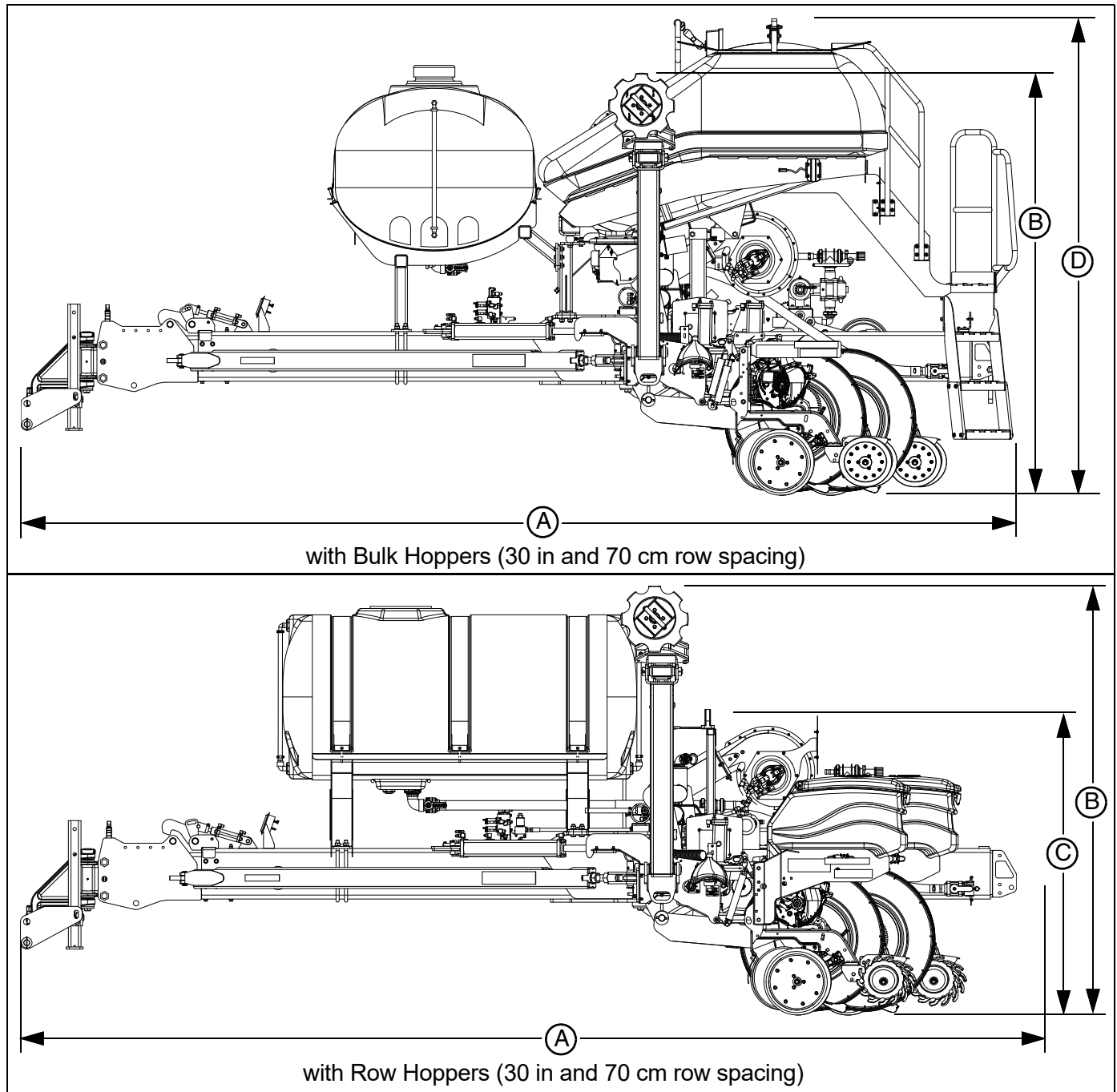

Callout	Description	Dimension
A	Length	20 ft 1 in (6.1m)
B	Height, Markers Folded	10 ft 6 in (3.2 m)
C	Height, Row Hoppers	8 ft 3 in (2.5 m)
D	Height, Bulk Hoppers	9 ft 2 in (2.8 m)

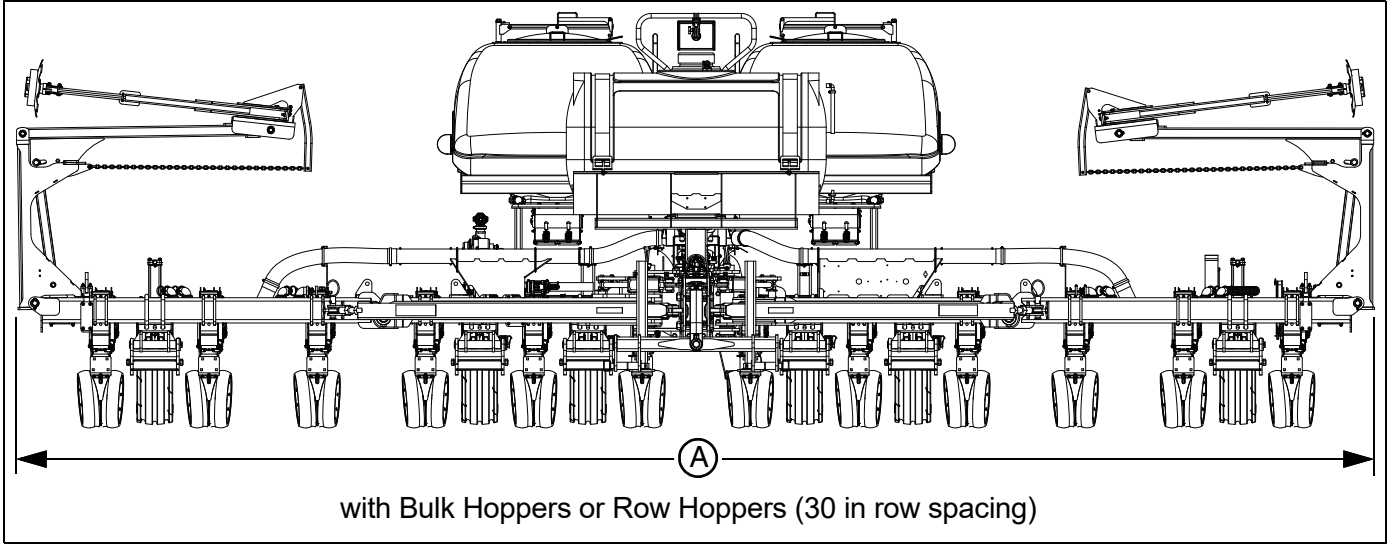

Callout	Description	Dimension
A	Width, Markers Folded	31 ft 4 in (9.5 m)

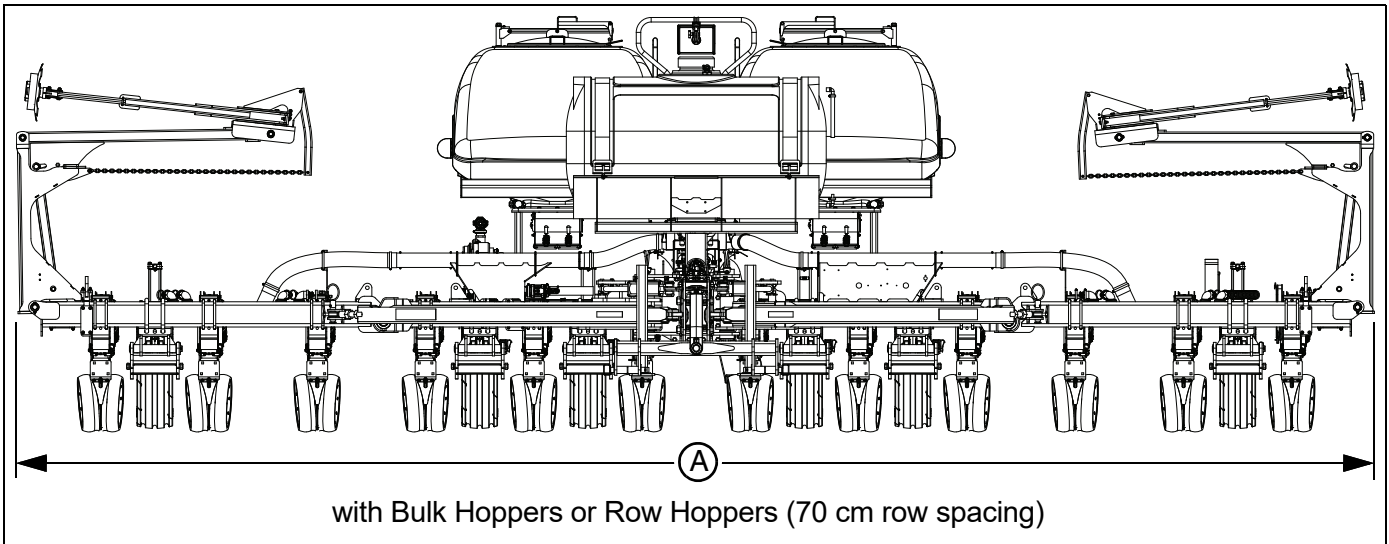

Callout	Description	Dimension
A	Width, Markers Folded	8.9 m (29 ft 4 in)

16-Row Planters

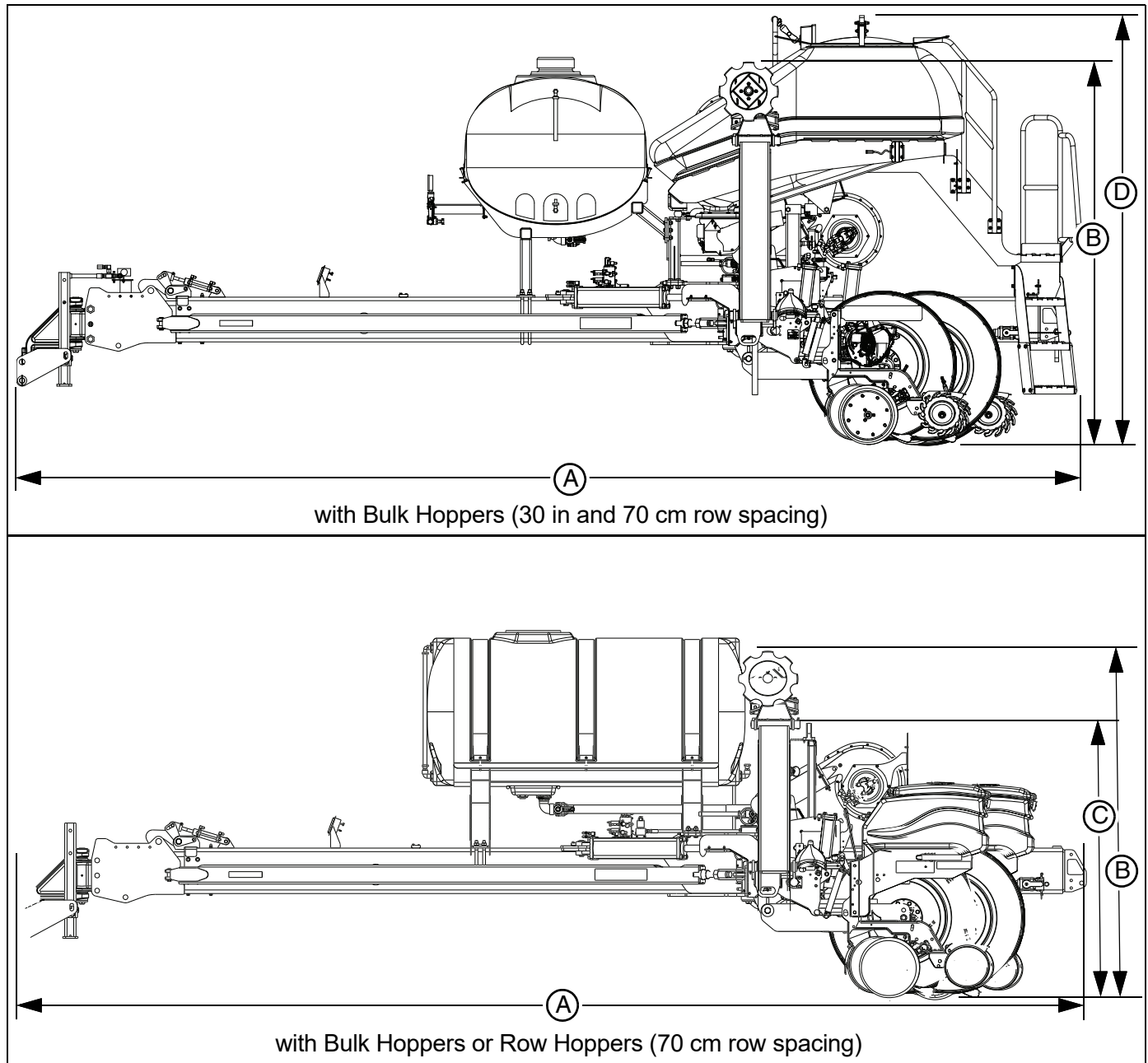

Callout	Description	Dimension
A	Length	23 ft 10 in (7.3 m)
B	Height, Markers Folded	8 ft 4 in (2.5 m)
C	Height, Row Hoppers	5 ft 10 in (1.6 m)
D	Height, Bulk Hoppers	9 ft 2 in (3.0 m)

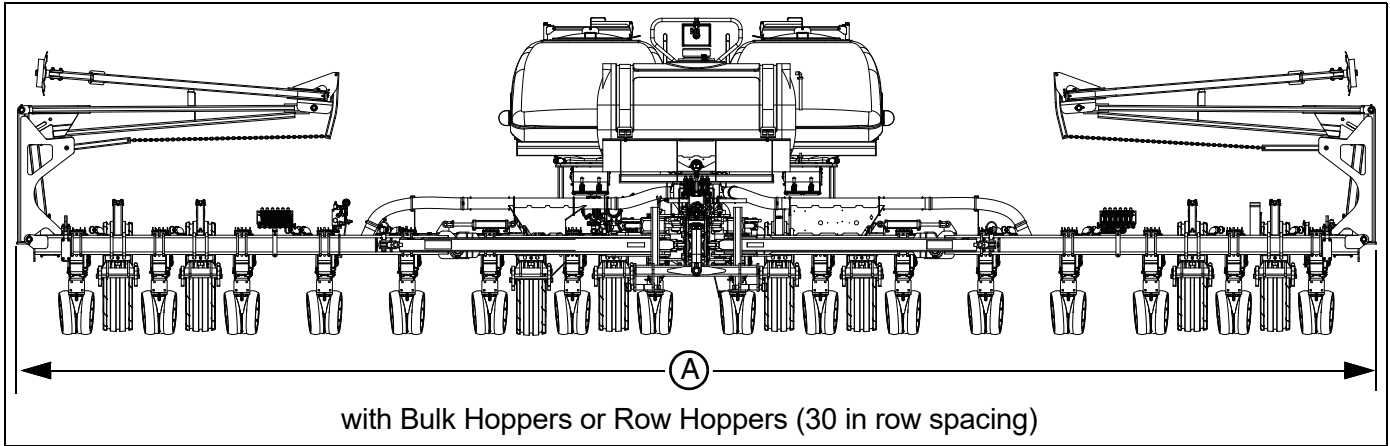

Callout	Description	Dimension
A	Width, Markers Folded	41 ft 2 in (12.5 m)

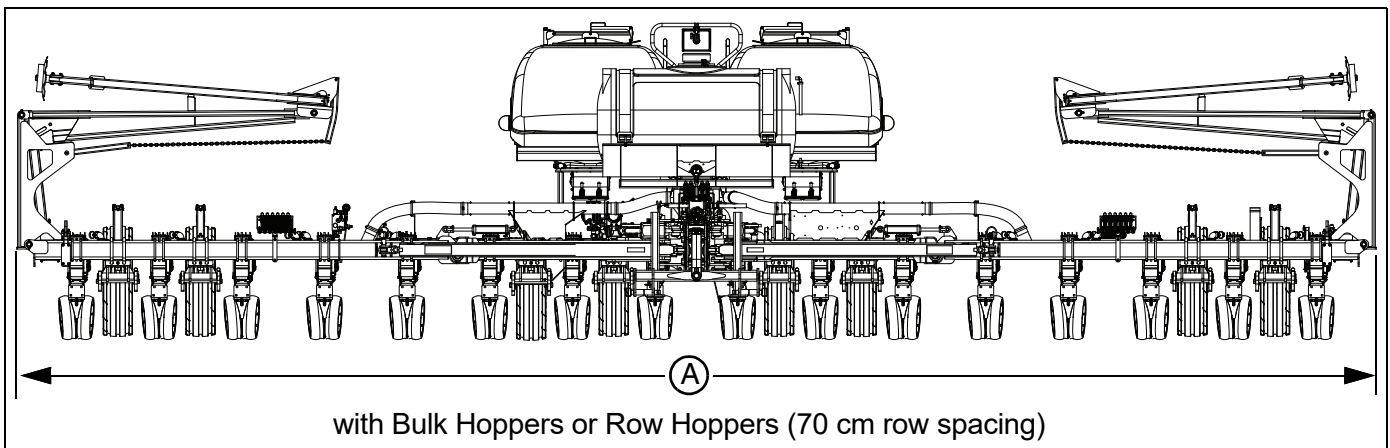

Callout	Description	Dimension
A	Width, Markers Folded	11.6 m (38 ft 1 in)

■ **Hydraulic Diagrams**

Lift Hydraulics - 12 Row Planters

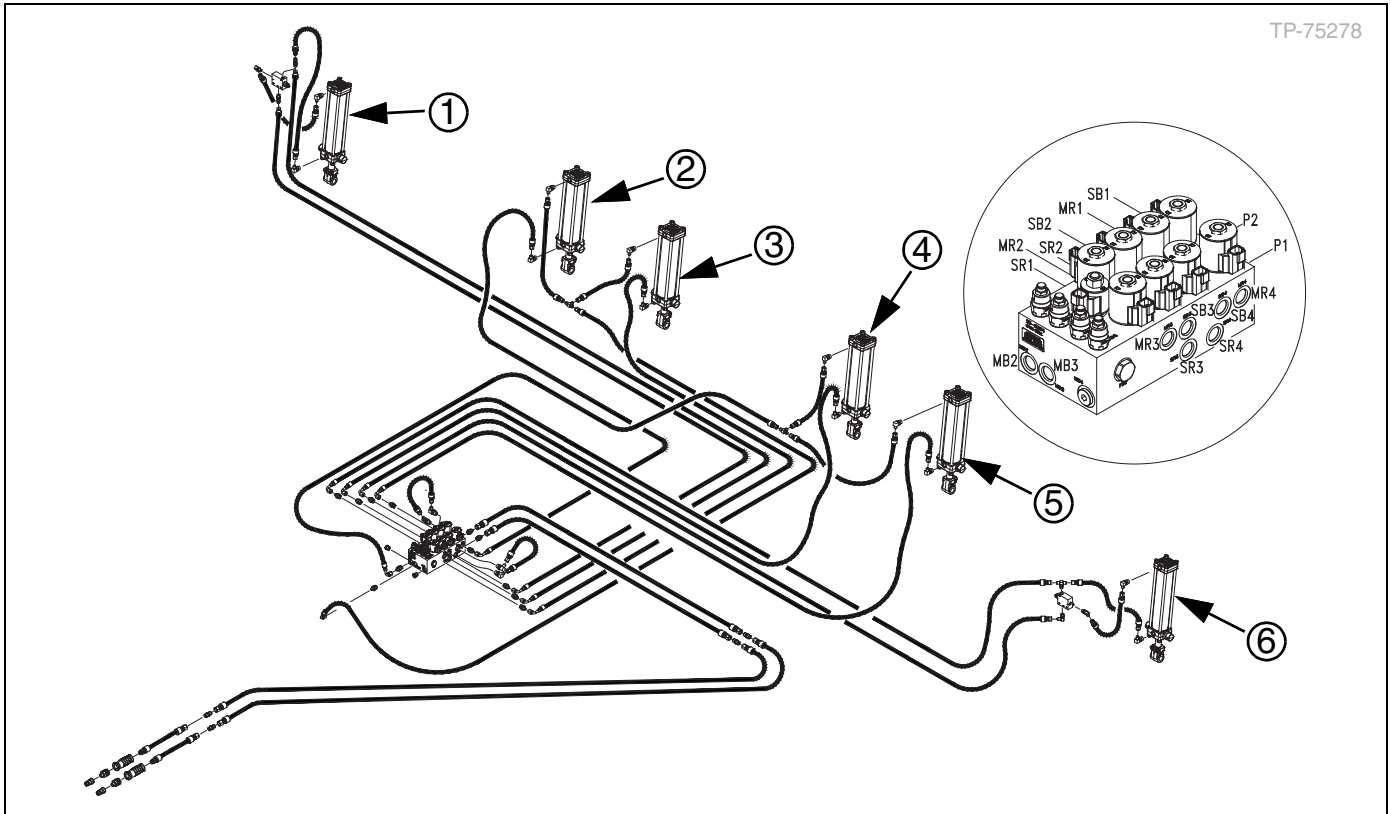

- (1) Wing gauge wheel, right cylinder
- (2) Transport wheel, right, outer cylinder
- (3) Transport wheel, right, inner cylinder
- (4) Transport wheel, left, inner cylinder
- (5) Transport wheel, left, outer cylinder
- (6) Wing gauge wheel, left cylinder

Lift Hydraulics - 16 Row Planters

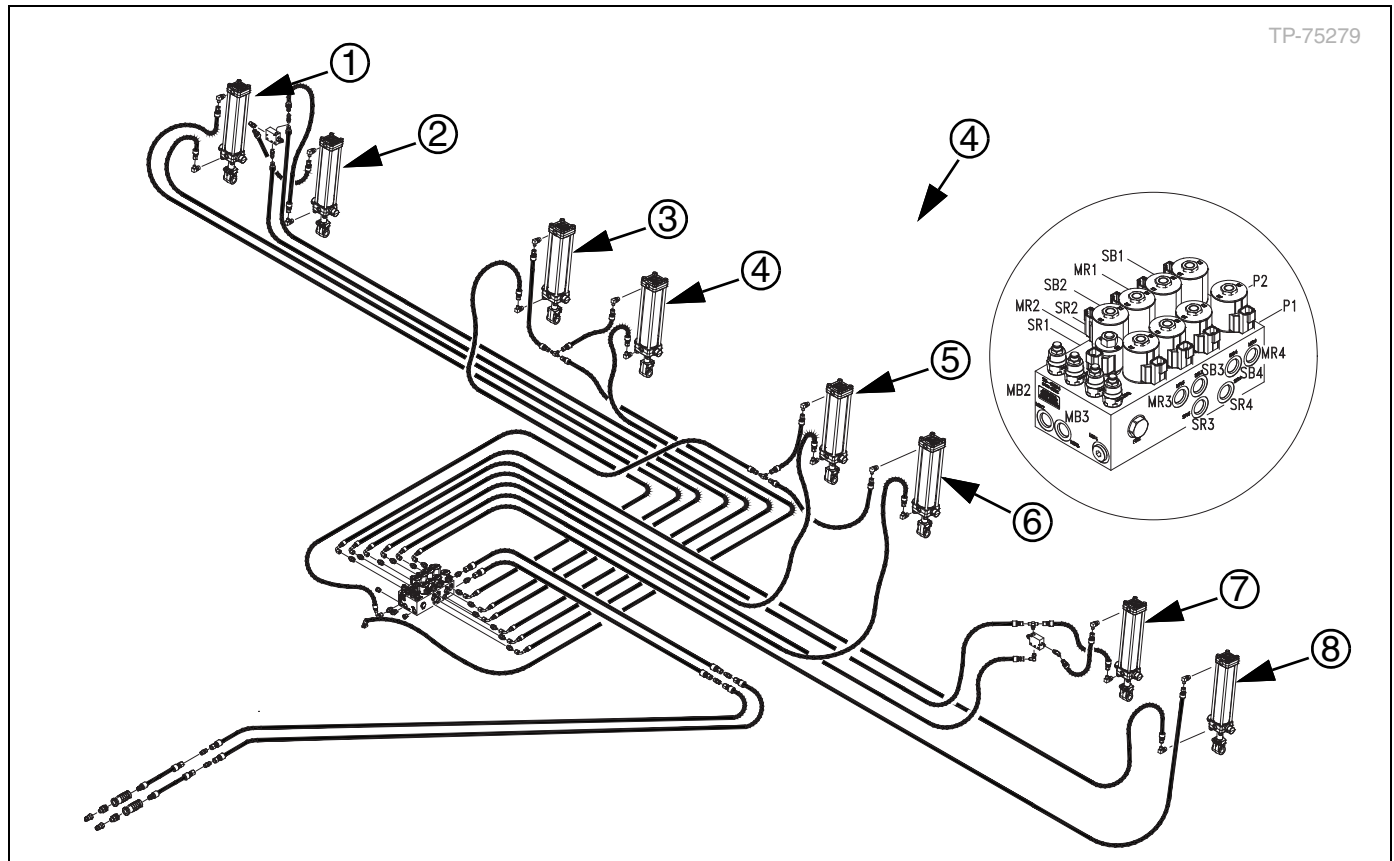

- (1) Wing gauge wheel, right, outer cylinder
- (2) Wing gauge wheel, right, inner cylinder
- (3) Transport wheel, right, outer cylinder
- (4) Transport wheel, right, inner cylinder
- (5) Transport wheel, left, inner cylinder
- (6) Transport wheel, left, outer cylinder
- (7) Wing gauge wheel, left, inner cylinder
- (8) Wing gauge wheel, left, outer cylinder

Fold Hydraulics

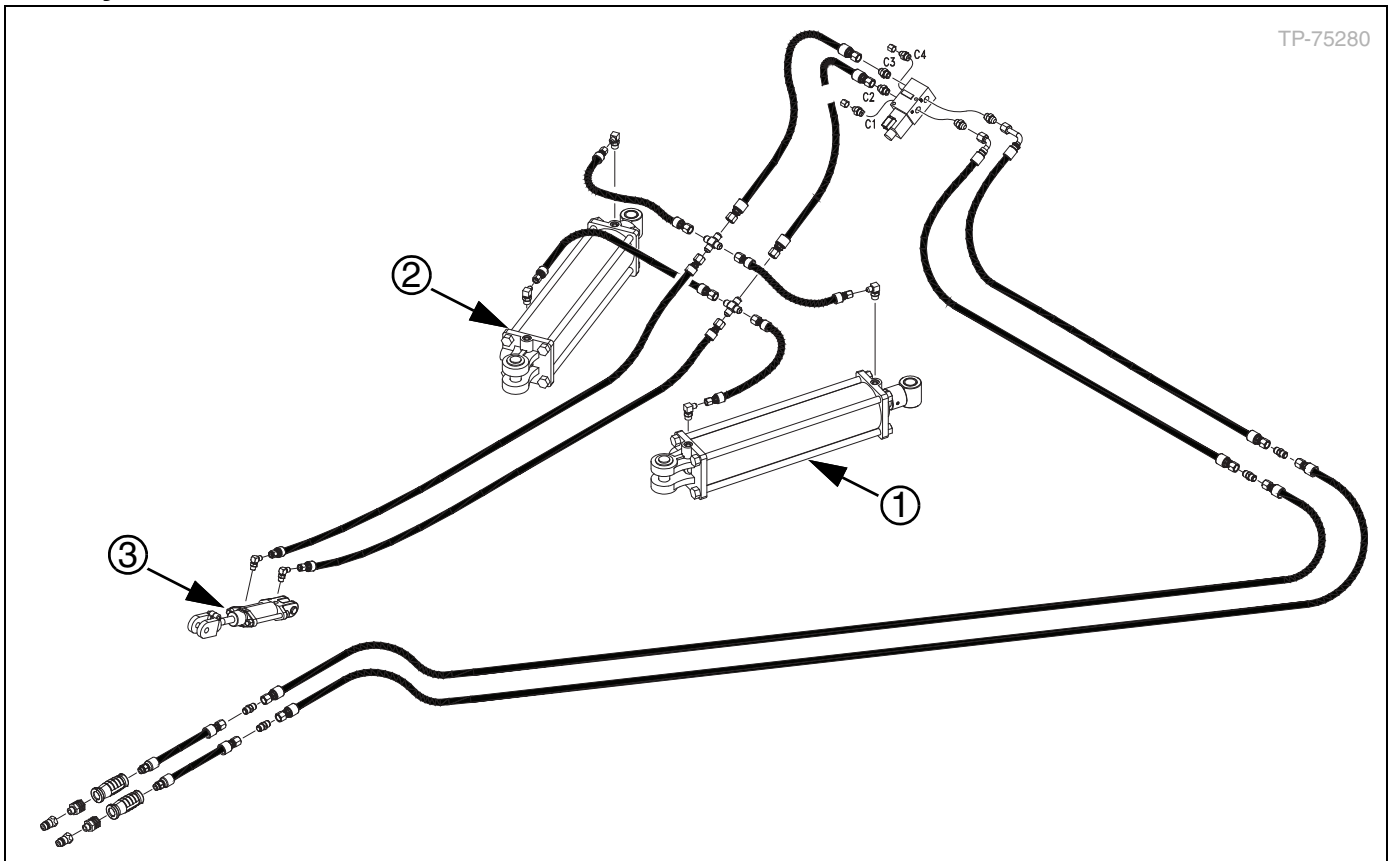

- (1) Fold cylinder, left
- (2) Fold cylinder, right
- (3) Tongue latch cylinder

Dual Fan Hydraulics - Bulk Hopper

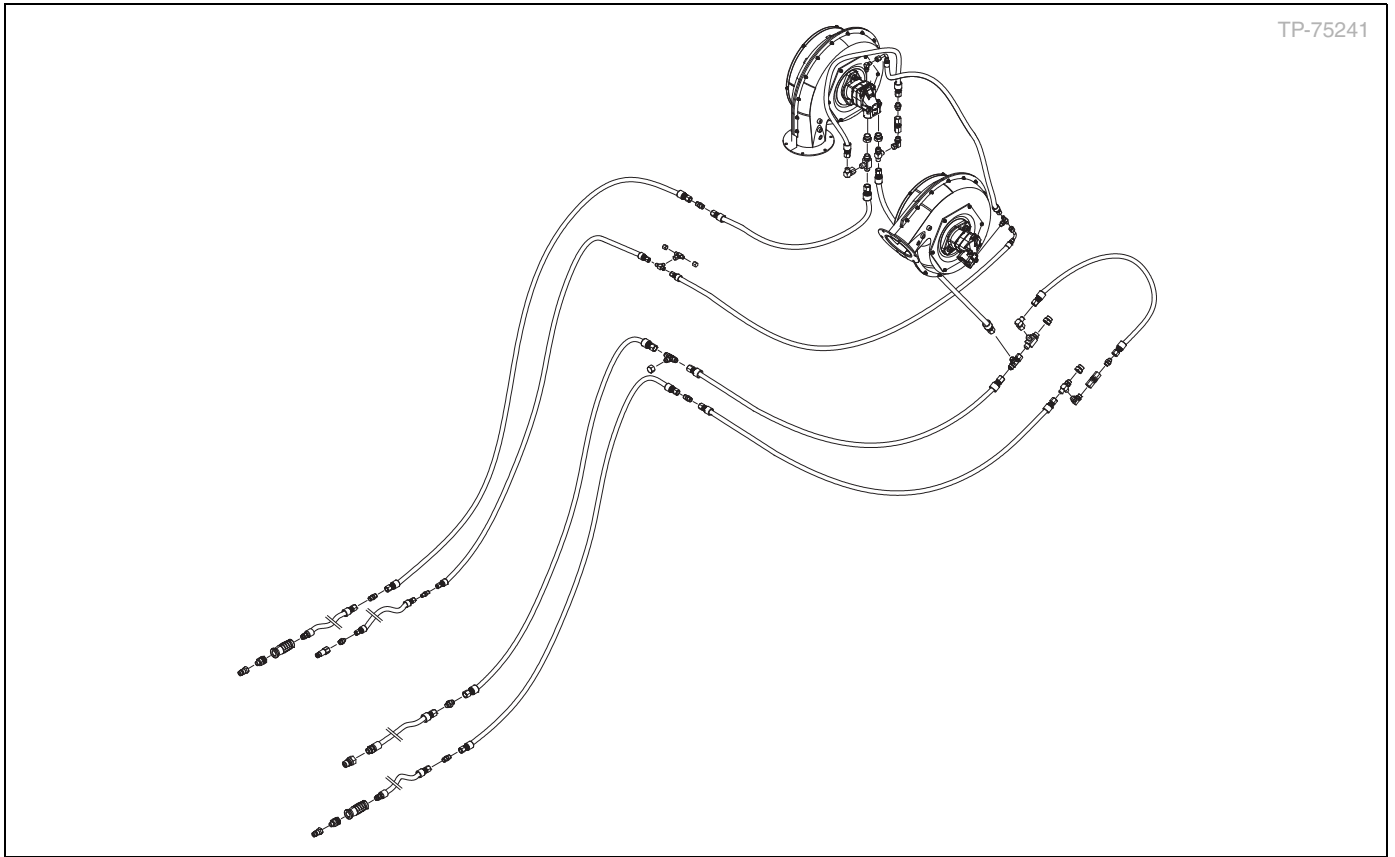

Single Fan Hydraulics - Row Hopper

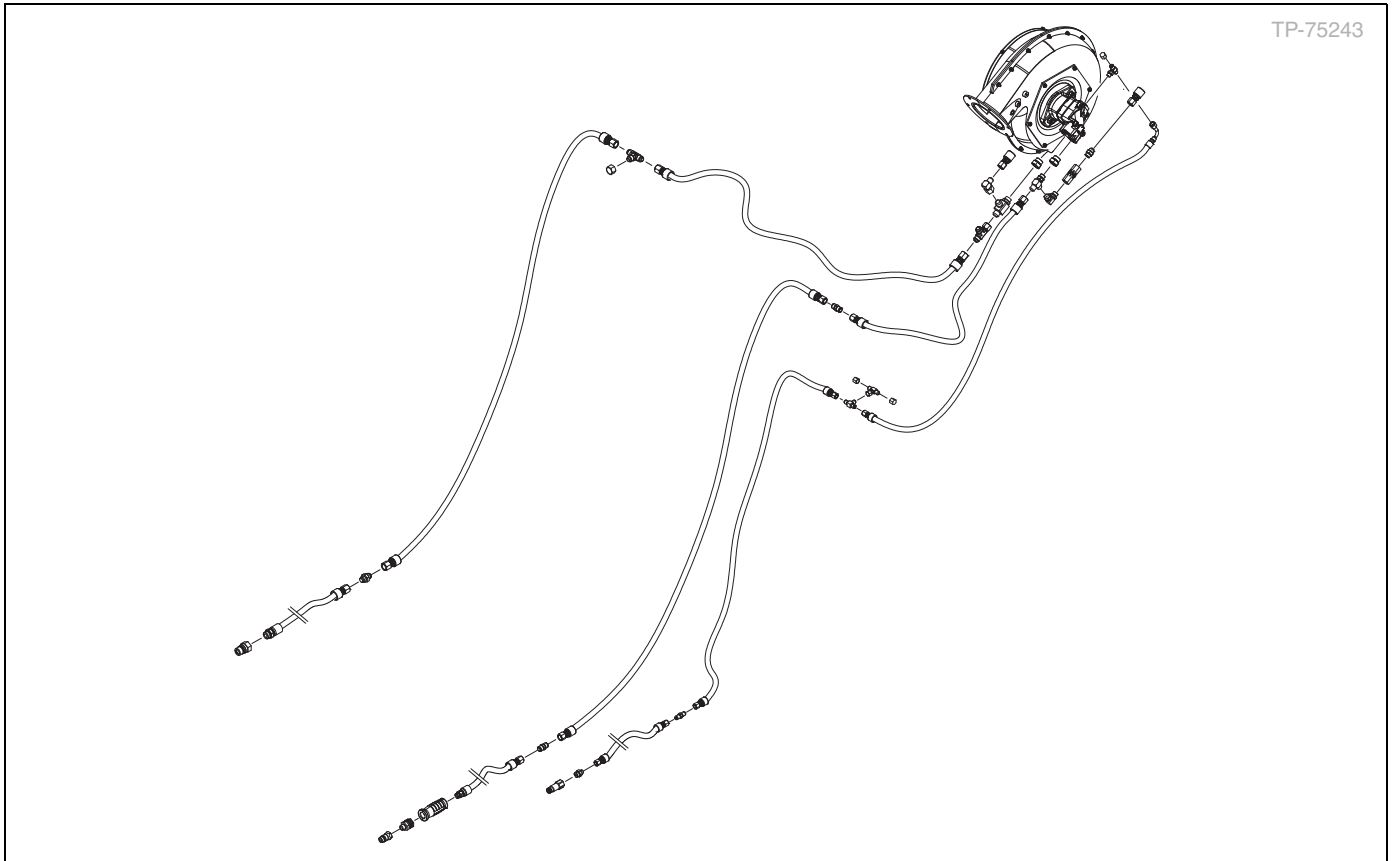

Marker Hydraulics

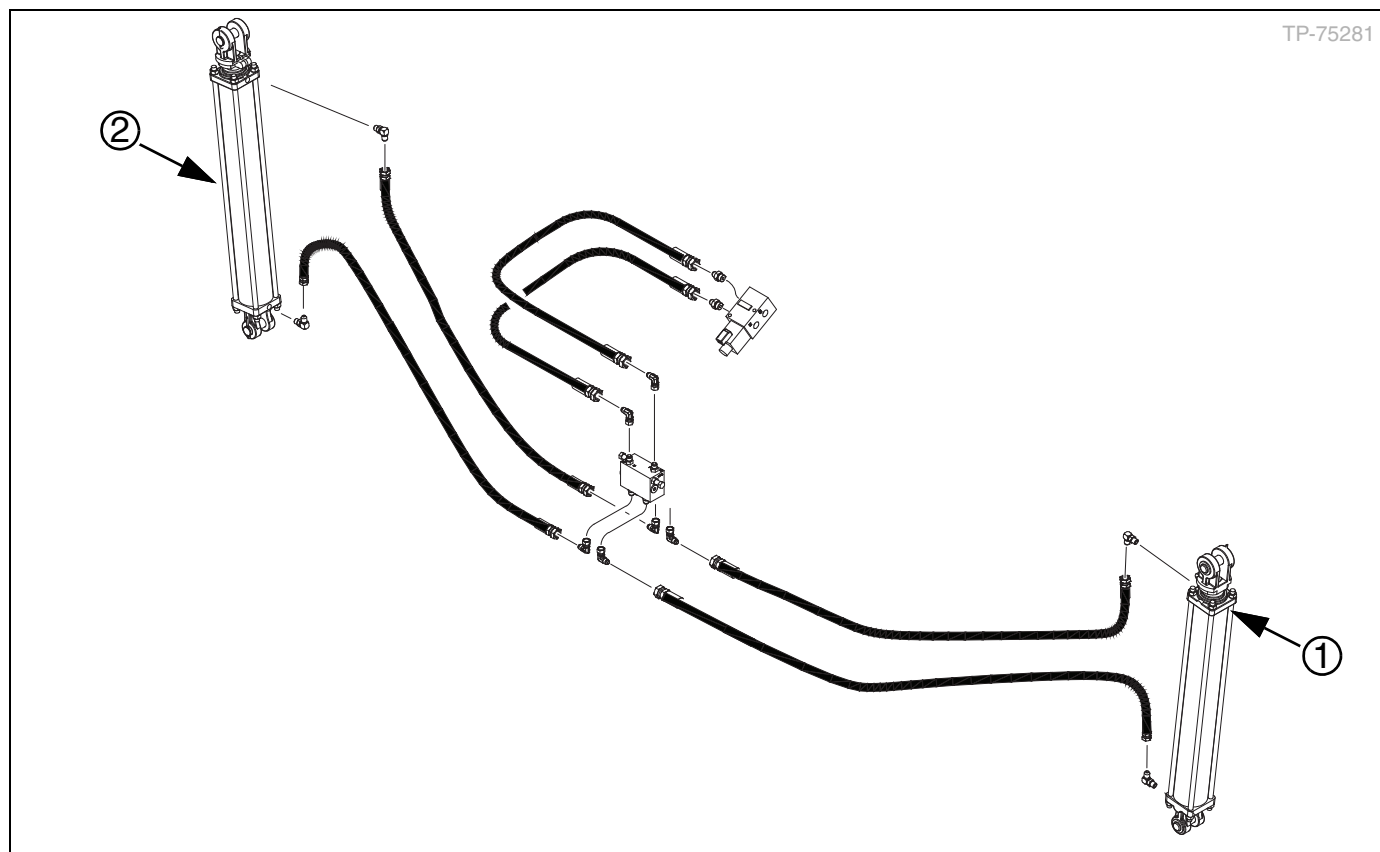

(1) Marker cylinder, left

(2) Marker cylinder, right

**Weight Transfer Hydraulics**

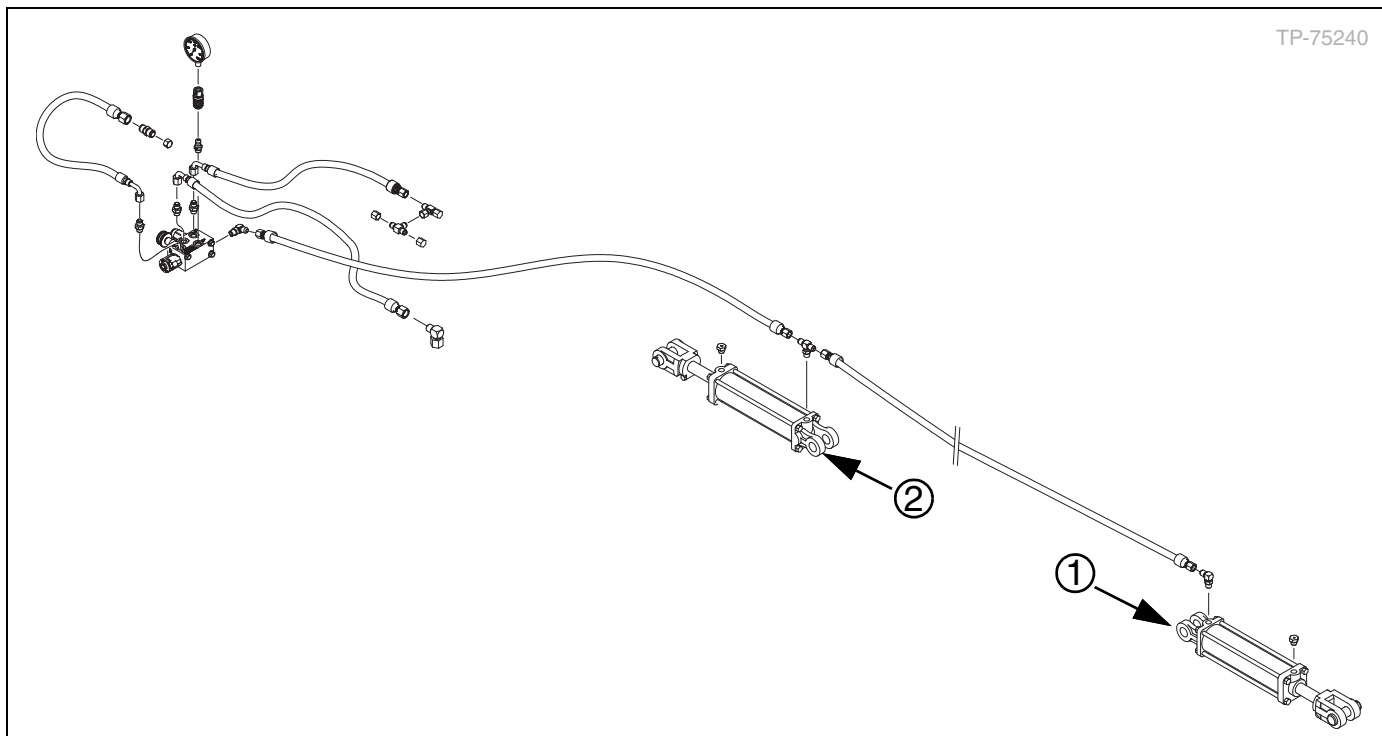

TP-75240

- (1) Cylinder, left
- (2) Cylinder, right

■ **Liquid Fertilizer Plumbing Diagrams**  
**30" Row Spacing Plumbing (S/N E1008B-)**

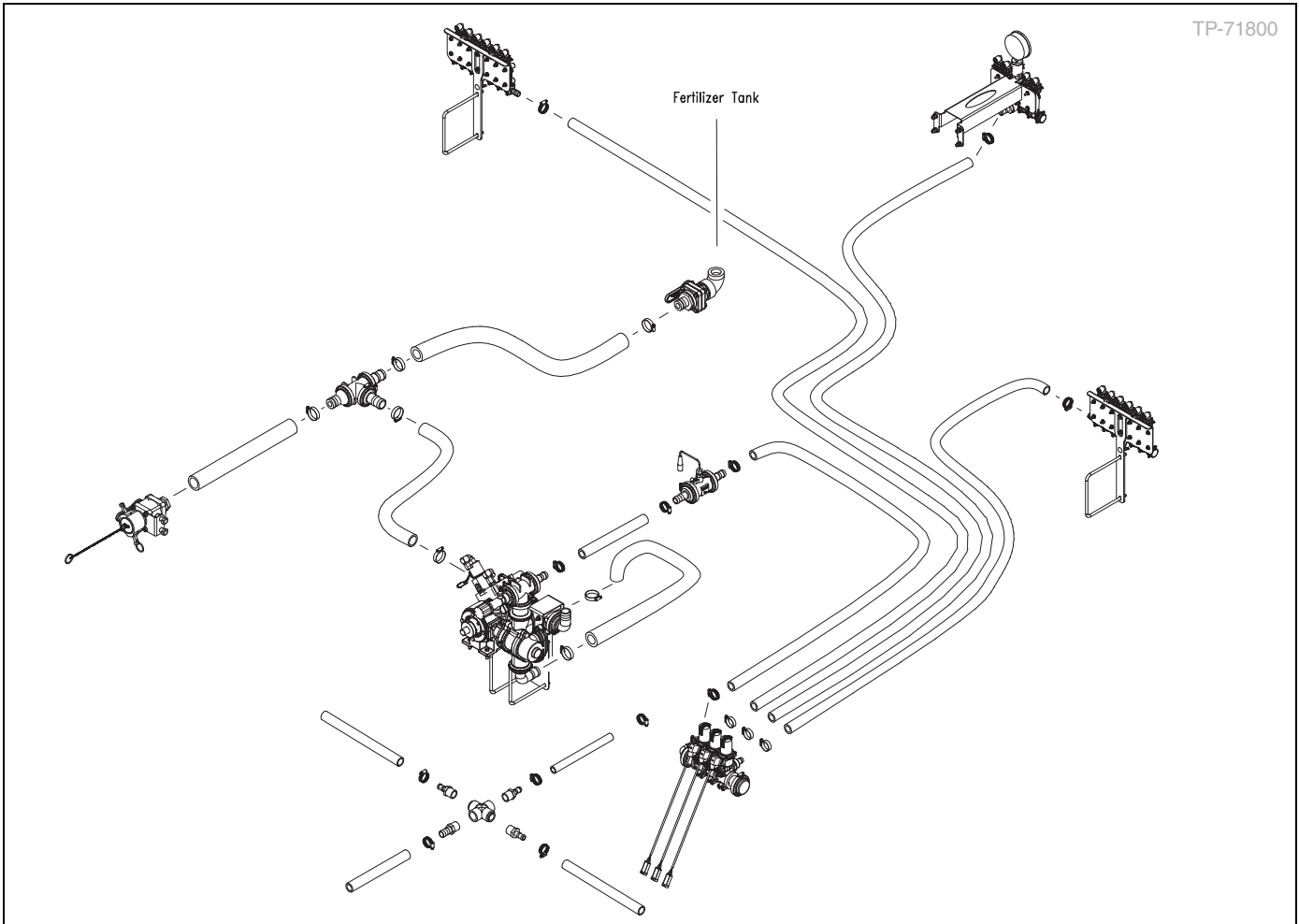

**30" Row Spacing Plumbing (S/N E1009B+)**

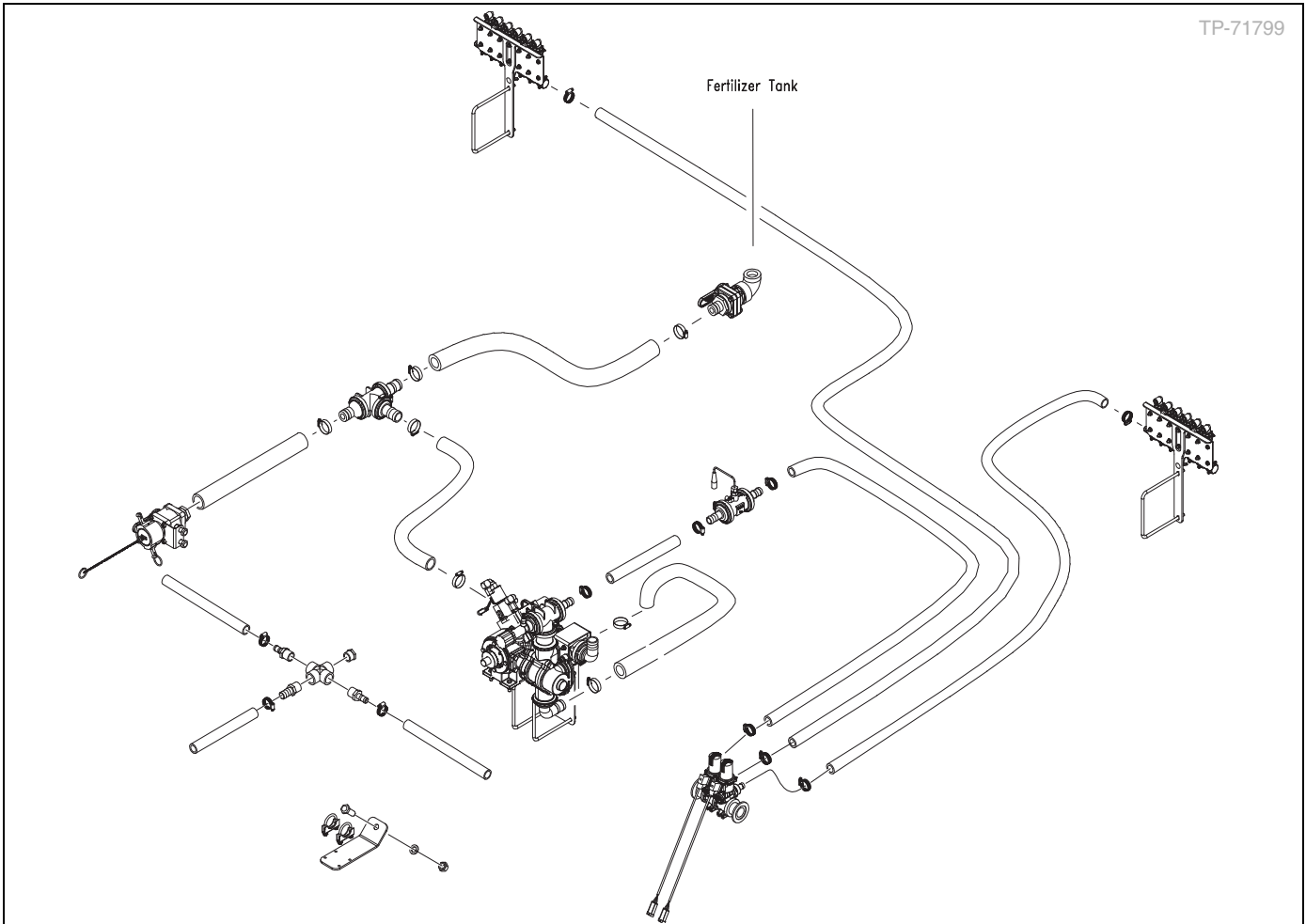

70 cm Row Spacing Plumbing

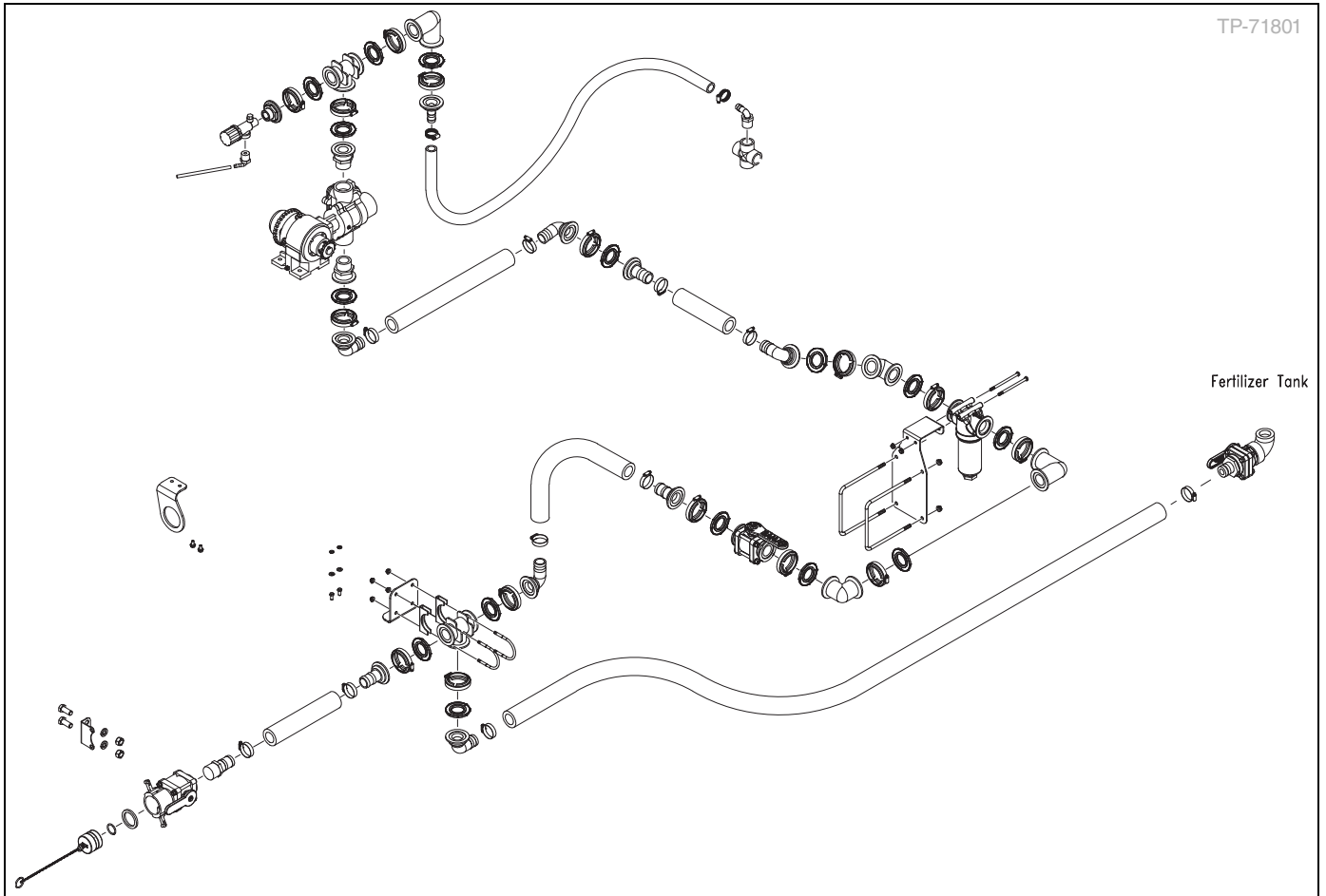

■ Fuse Box Diagrams

12-and-16 Row with Switch Box

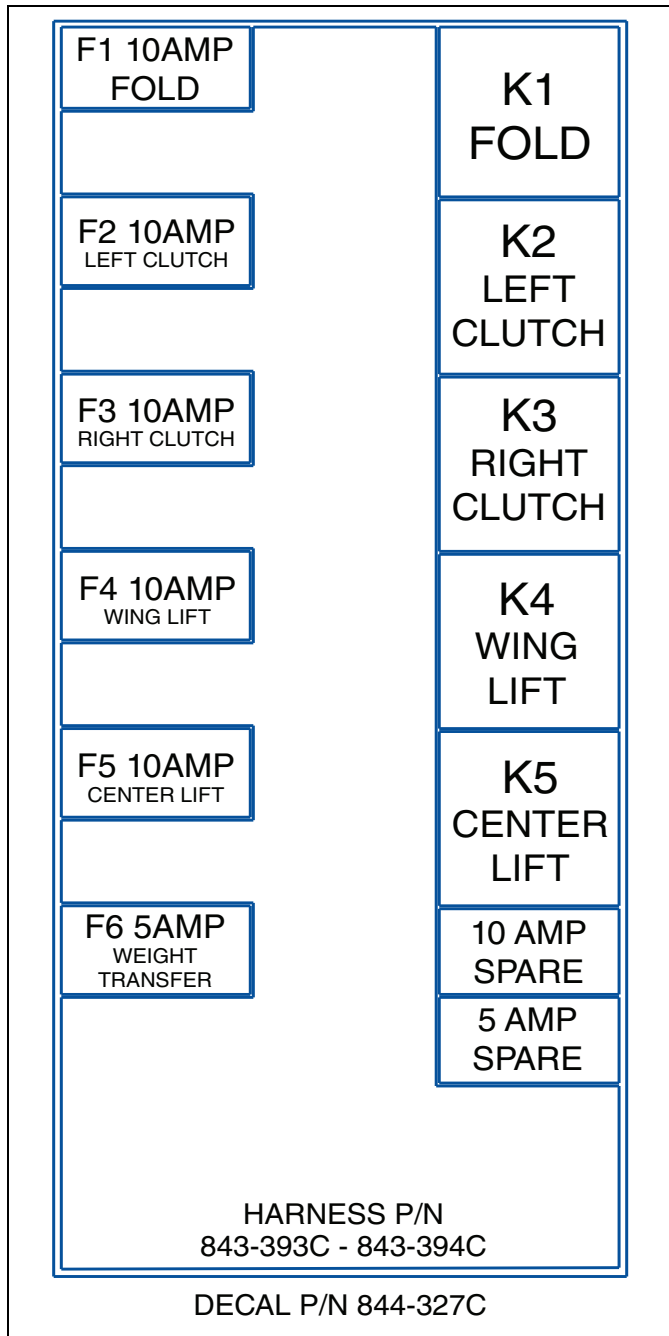

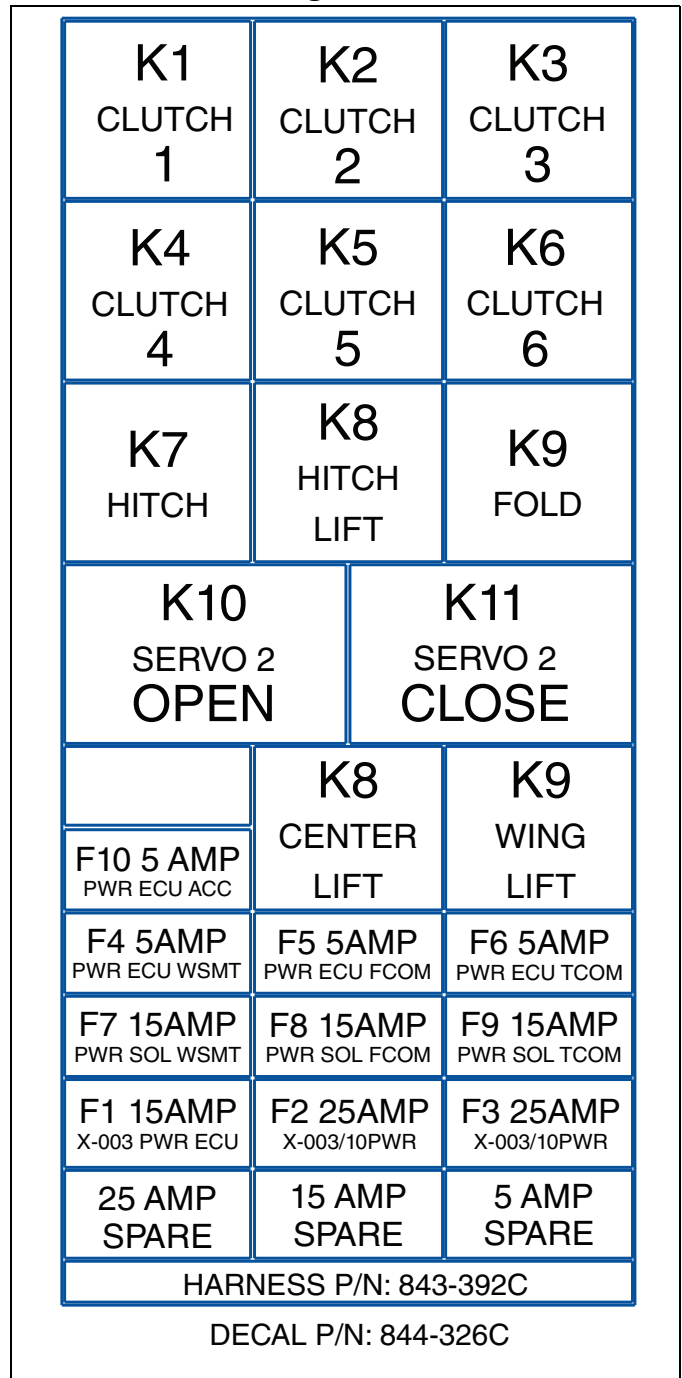

12 Row with IntelliAg ISO6



16 Row with IntelliAg ISO6

K1 CLUTCH 1	K2 CLUTCH 2	K3 CLUTCH 3
K4 CLUTCH 4	K5 CLUTCH 5	K6 CLUTCH 6
K7 CLUTCH 7	K8 HITCH	K9 FOLD
K10 SERVO 2 OPEN		K11 SERVO 2 CLOSE
K12 CLUTCH 8	K13 CENTER LIFT	K14 WING LIFT
F4 5AMP PWR ECU WSMT	F5 5AMP PWR ECU FCOM	F6 5AMP PWR ECU TCOM
F7 15AMP PWR SOL WSMT	F8 15AMP PWR SOL FCOM	F9 15AMP PWR SOL TCOM
F1 15AMP X-003 PWR ECU	F2 25AMP X-003/10PWR	F3 25AMP X-003/10PWR
F10 5AMP PWR ECU ACC	15 AMP SPARE	5 AMP SPARE
HARNESS P/N: 843-468C		
DECAL P/N: 844-334C		



IRC

F1 60 AMP 12V AUX PWR	K1 AUX PWR RELAY		S P A R E
D1  SOFT START	5AMP IRC ROW ECUs	15AMP PWR FCOM SOL	
D2  SOFT START	5AMP PWR ECU ACC	5AMP FCOM ECU	
15AMP WSMT SOL	K2 CENTER LIFT	K8 WING LIFT	
5AMP WSMT ECU			
25AMP 24V LEFT	25AMP 24V CENTER	25AMP 24V RIGHT	
K3 SEED DELIVERY AIR CONTROL		K4 SEED DELIVERY AIR CONTROL	
K5 FOLD VALVE	K6 HITCH LIFT VALVE	K7 HITCH VALVE	
HARNESS P/N: 843-391C			
DECAL P/N: 844-328C			

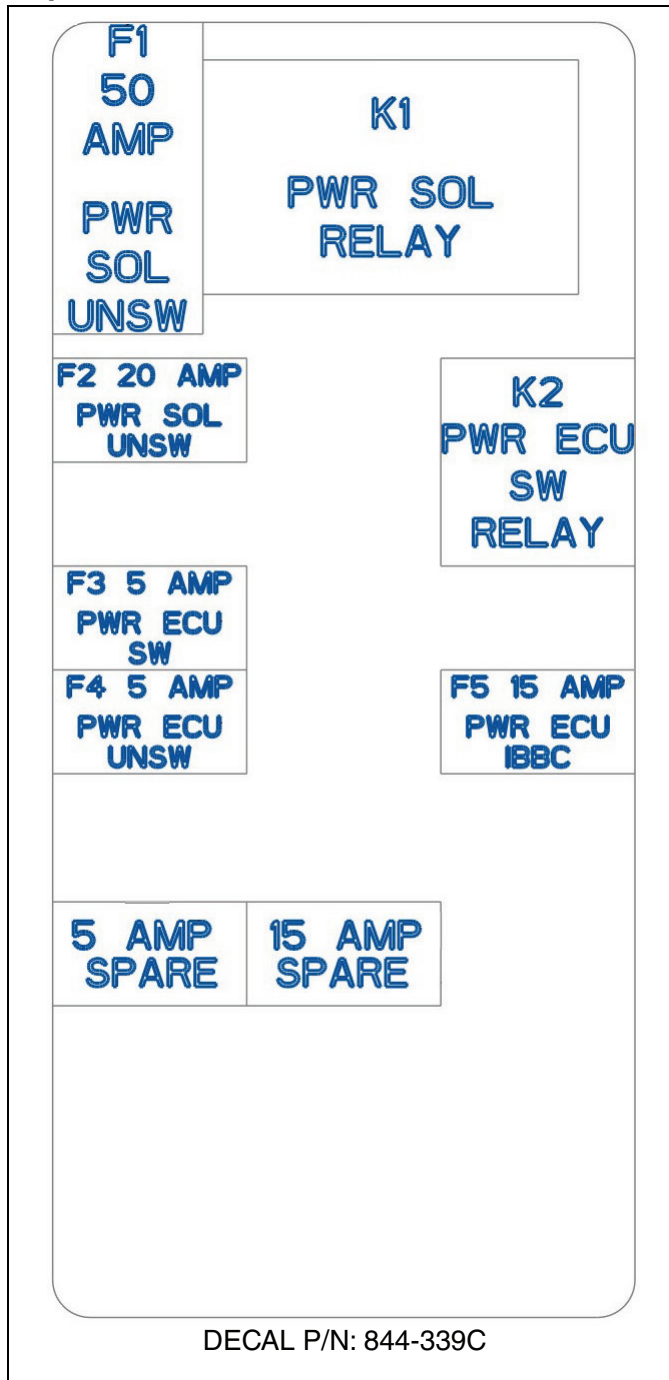
Topcon XD and XD-Plus



■ **Torque Value Chart**

Bolt Size in-tpi <sup>a</sup>	Bolt Head Identification					
						
	Grade 2		Grade 5		Grade 8	
	N-m <sup>b</sup>	ft-lb <sup>d</sup>	N-m	ft-lb	N-m	ft-lb
1/4-20	7.4	5.6	11	8	16	12
1/4-28	8.5	6	13	10	18	14
5/16-18	15	11	24	17	33	25
5/16-24	17	13	26	19	37	27
3/8-16	27	20	42	31	59	44
3/8-24	31	22	47	35	67	49
7/16-14	43	32	67	49	95	70
7/16-20	49	36	75	55	105	78
1/2-13	66	49	105	76	145	105
1/2-20	75	55	115	85	165	120
9/16-12	95	70	150	110	210	155
9/16-18	105	79	165	120	235	170
5/8-11	130	97	205	150	285	210
5/8-18	150	110	230	170	325	240
3/4-10	235	170	360	265	510	375
3/4-16	260	190	405	295	570	420
7/8-9	225	165	585	430	820	605
7/8-14	250	185	640	475	905	670
1-8	340	250	875	645	1230	910
1-12	370	275	955	705	1350	995
1 1/8-7	480	355	1080	795	1750	1290
1 1/8-12	540	395	1210	890	1960	1440
1 1/4-7	680	500	1520	1120	2460	1820
1 1/4-12	750	555	1680	1240	2730	2010
1 3/8-6	890	655	1990	1470	3230	2380
1 3/8-12	1010	745	2270	1670	3680	2710
1 1/2-6	1180	870	2640	1950	4290	3160
1 1/2-12	1330	980	2970	2190	4820	3560

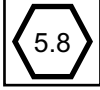
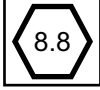
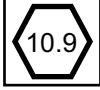
Bolt Size mm x pitch <sup>c</sup>	Bolt Head Identification					
						
	Class 5.8		Class 8.8		Class 10.9	
	N-m	ft-lb	N-m	ft-lb	N-m	ft-lb
M 5 X 0.8	4	3	6	5	9	7
M 6 X 1	7	5	11	8	15	11
M 8 X 1.25	17	12	26	19	36	27
M 8 X 1	18	13	28	21	39	29
M10 X 1.5	33	24	52	39	72	53
M10 X 0.75	39	29	61	45	85	62
M12 X 1.75	58	42	91	67	125	93
M12 X 1.5	60	44	95	70	130	97
M12 X 1	90	66	105	77	145	105
M14 X 2	92	68	145	105	200	150
M14 X 1.5	99	73	155	115	215	160
M16 X 2	145	105	225	165	315	230
M16 X 1.5	155	115	240	180	335	245
M18 X 2.5	195	145	310	230	405	300
M18 X 1.5	220	165	350	260	485	355
M20 X 2.5	280	205	440	325	610	450
M20 X 1.5	310	230	650	480	900	665
M24 X 3	480	355	760	560	1050	780
M24 X 2	525	390	830	610	1150	845
M30 X 3.5	960	705	1510	1120	2100	1550
M30 X 2	1060	785	1680	1240	2320	1710
M36 X 3.5	1730	1270	2650	1950	3660	2700
M36 X 2	1880	1380	2960	2190	4100	3220

- a. in-tpi = nominal thread diameter in inches-threads per inch
- b. N·m = newton-meters
- c. mm x pitch = nominal thread diameter in mm x thread pitch
- d. ft-lb = foot pounds

Torque tolerance + 0%, -15% of torquing values. Unless otherwise specified use torque values listed above.

25199

■ **Tire Information**

Tire Size	Maximum Tire Pressure	Wheel Bolt Torque
VF295/75R22.5 AD2	64 psi (441 kPa)	240 lb ft (325 Nm)
13.5 x 6 - Contact Wheel for 30" Row Spacing	40 psi (276 kPa)	-

**Tire Warranty Information**

All tires are warranted by the original manufacturer of the tire. Tire warranty information is found online at the manufacturer's websites listed below. For assistance or information, contact your nearest authorized farm tire retailer.

Manufacturer	Website
Firestone	www.firestoneag.com

## Pre-Delivery Instructions



### **Crush and Pinch Hazards**

A falling section or part can cause severe injury or death by crushing. Always keep body and body parts out from under any parts or components of the planter. Ensure all equipment is properly rated for the load before attempting to unload the planter, move parts, or assemble the planter. Ensure all equipment operates with smooth movements before beginning work.



### **Secure Machine**

It is necessary for the shipping chain or strap securing the wings to the tongue to remain in place until the planter has been unloaded from the trailer. Do not attempt to unfold the planter when the shipping chain is installed. The shipping chain or strap should not secure any part of the planter to the trailer. Failure to keep shipping chain or strap secured during unloading can result in the planter becoming unbalanced. A falling planter can cause severe injury or death.



### **Flailing Hazard**

Marker hydraulics are active whenever the fold hydraulics are not in use. It is important to set the tractor fold/marker hydraulic circuit lever to "Float" or "Neutral" to prevent unintended marker operations. Unexpected marker operation and flailing equipment can seriously injure including death.



### **Frame Damage Risk**

Do not raise/lower the wing gauge wheels at any time with shipping chain or strap installed on tongue. While the shipping chain is installed the planter lift hydraulic system should only be operated as "Center" or "Center Lift" or planter frame damage can occur.

This section covers instructions exclusively for the dealer to assemble and produce a properly working machine for the customer. All workers must read and understand this entire manual before beginning assembly and setup.

The instructions in this section are not intended for customer use.

Illustrations in this section were not completed during an actual assembly. For clarity, some illustrations may or may not include parts, assemblies, and other components at the same point in an actual assembly.

Ensure you have all the necessary tools and equipment before beginning assembly. Ensure heavy machinery and tools are properly rated for tasks.

As the assembly steps are completed, ensure removed items or items set aside are a safe distance away from work area and will continue to allow for adequate space to safely complete assembly.

It is the dealer's responsibility to unload the PL5700 planter. Unload all equipment before beginning assembly. Do not attempt any work with the PL5700 while on the truck. It is the dealer's responsibility to ensure any workers or others in close proximity of the planter are familiar and understand the contents of this manual, and are properly trained to work, assemble, operate, and perform maintenance on the planter and the other machinery used to assemble the PL5700 planter.

## ■ Requirement Checklist

- ☑ Read and understand "Safety Information" on page 2 before beginning to assemble the planter.
- ☑ Have at least two people on hand during assembly.
- ☑ Appoint a designated observer and have a plan to safely complete assembly.
- ☑ Ensure the assembly location is level and free of obstructions and debris. Great Plains recommends an open, concrete area.
- ☑ Have all major components and required tools. Test to ensure they are properly working before beginning work.
- ☑ Account for all loose components, fasteners, and pins shipped with the PL5700 planter.
- ☑ Use a tractor of sufficient size and horsepower with at least three hydraulic circuits. Refer to "Specifications" on page 94 for tractor requirements.
- ☑ Ensure safety decals and reflectors are located correctly and legible. Replace if improperly located or damaged. Refer to "Safety Decals" on page 5.
- ☑ Have a copy of the parts manual on hand for reference. If unsure of proper placement or use of any part or fastener, refer to the parts manual.

## Tools Required

- PL5700 Planter parts manual (411-681P).
- General hand tools.
- Suitable tractor. See "Specifications" on page 94.

## ■ Unloading Planter



**High Pressure Fluid Hazard**

Escaping fluid under pressure can have sufficient pressure to penetrate the skin. Check all hydraulic lines and fittings before applying pressure. Use paper or cardboard, not body parts, and wear heavy gloves to check for suspected leaks. If injured, seek immediate medical attention from a physician familiar with this type of injury.



**Planter Damage Risk**

It is essential for the hydraulic systems connections to be made and for the in-cab console, or switch box, to be connected to the tractor before attempting to unload the planter from the trailer.

**With IntelliAg ISO6**

1. Ensure all chain and tie-down straps have been released and stowed. Do not remove the tongue shipping chain or strap securing the wings to the tongue.
2. Move the tractor close to the planter hitch.
3. Adjust the tractor 3-point arms and sway blocks to minimize side-to-side sway when transporting. See your tractor's operator manual for information.
4. Raise the hitch height high enough to clear the drawbar.
5. Back the tractor to align the drawbar and hitch.
6. Connect the tractor to the planter. If using a quick hitch, ensure the planter locks into the hitch securely.
7. Raise the hitch high enough to take pressure off the parking stands.
8. Remove each pin (1) and slide up the parking stand.

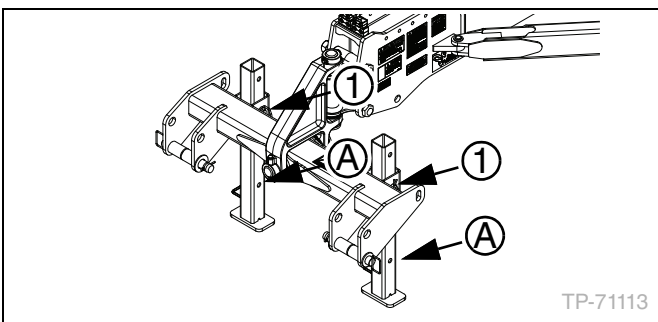

9. Install the pins (1) in the bottom hole (A) of the parking stands.
10. Make lift hydraulic connections from tractor circuit to planter.

11. Make all electrical connections from planter to tractor.
12. With your in-cab console, tap the Fold Sequence softkey from the Home screen.

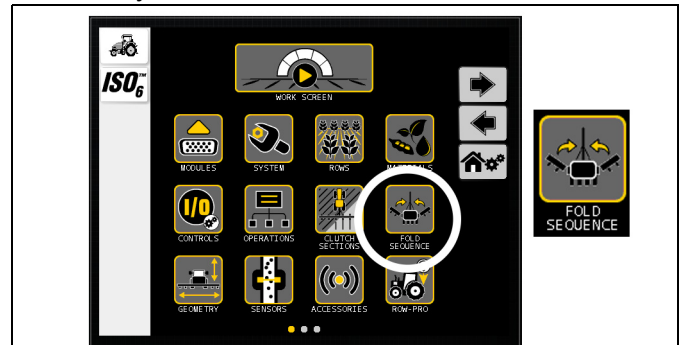

13. Tap the Center Lift softkey to set the Center Lift hydraulic system to active. This is indicated by the Center Lift softkey changing to a blue Active Center Lift softkey.

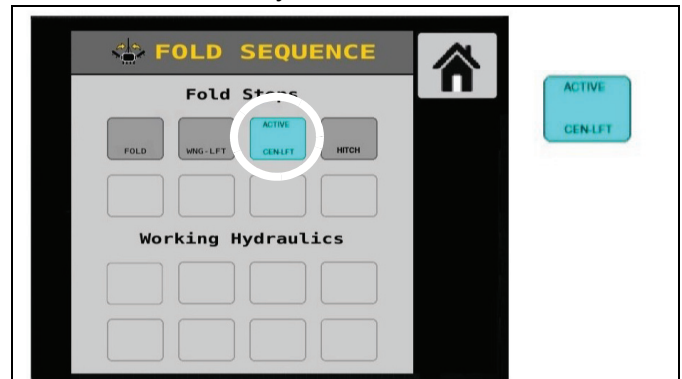

14. Use tractor lift circuit lever to raise the center of the planter.
15. Set tractor lift circuit lever to "Neutral".
16. Install cylinder locks.



17. Using caution and care, pull the planter slowly off the trailer bed.
18. Set tractor lift circuit lever to "Neutral".
19. Remove cylinder locks and stow in storage position.

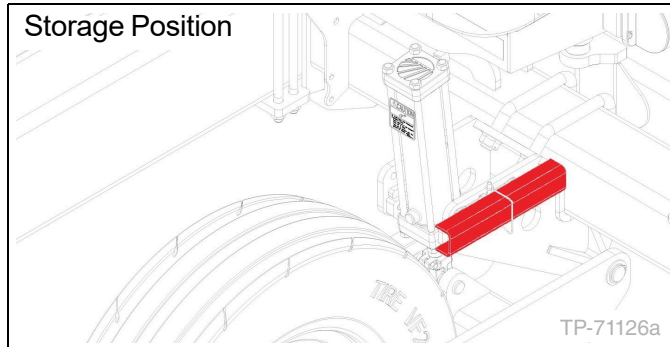

20. Use the tractor circuit lift lever to slowly lower the planter to the ground.
21. Set tractor lift circuit lever to "Neutral".
22. Tap the Active Center Lift softkey so the center lift hydraulic system is no longer active.

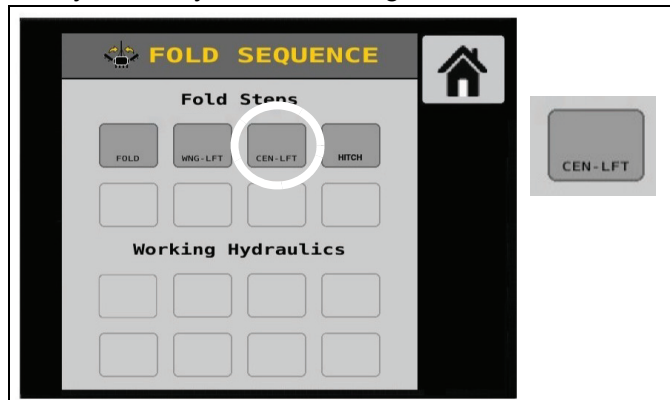

**With Switch Box**

1. Ensure all chain and tie-down straps have been released and stowed. Do not remove the tongue shipping chain or strap securing the wings to the tongue.
2. Move the tractor close to the planter hitch.
3. Adjust the tractor 3-point arms and sway blocks to minimize side-to-side sway when transporting. See your tractor's operator manual for information.
4. Raise the hitch height high enough to clear the drawbar.
5. Back the tractor to align the drawbar and hitch.
6. Connect the tractor to the planter. If using a quick hitch, ensure the planter locks into the hitch securely.

7. Raise the hitch high enough to take pressure off the parking stands.
8. Remove each pin (1) and slide up the parking stand.

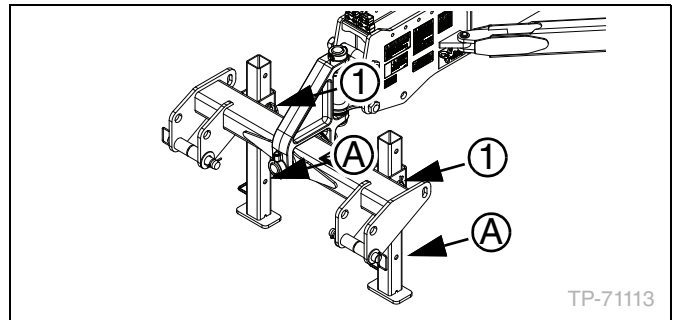

9. Install the pins (1) in the bottom hole (A) of the parking stands.
10. Make lift hydraulic connections from tractor circuit to planter.
11. Make all electrical connections from planter to tractor.
12. One the switch box, toggle the on/off power switch to ON.



13. On the switch box, toggle the marker/fold switch to **MARKER**.



14. On the switch box, toggle the lift switch to the position *CENTER*.



15. Use the tractor lift circuit lever to raise the center frame of the planter.

16. Set tractor lift circuit lever to "Neutral".

17. Install cylinder locks.

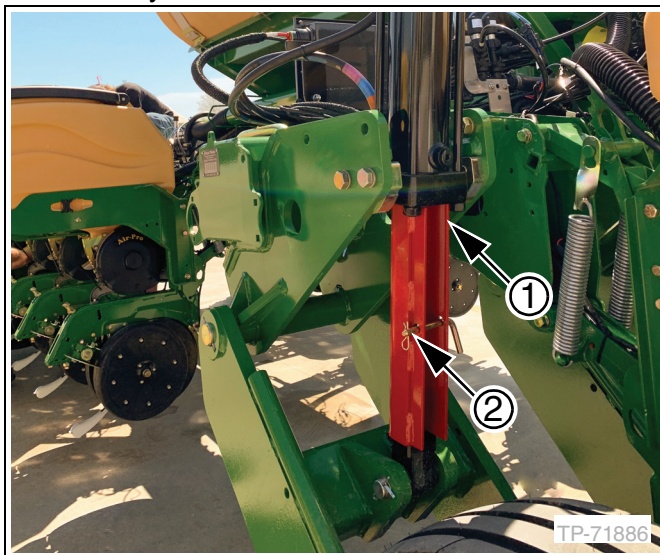

18. Using caution and care, pull the planter slowly off the trailer bed.

19. Set tractor lift circuit lever to "Neutral".

20. Remove cylinder locks and stow in storage position.

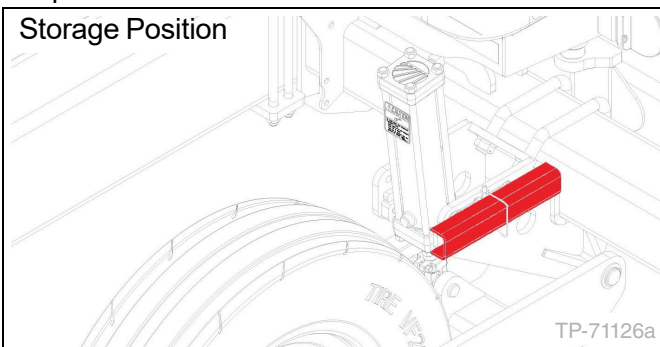

21. Use the tractor circuit lift lever to slowly lower the planter to the ground.

22. Set tractor lift circuit lever to "Neutral".

## ■ Shipping Check Valve Removal



### **High Pressure Fluid Hazard**

The hydraulic system comes from the factory fully charged. Great Plains strongly recommends that all hydraulic system adjustments and repair to be completed by a trained professional who is knowledgeable about how to safely complete hydraulic system work. Do not pinch or damage hydraulic hoses. Compromising a closed hydraulic system can cause serious injury or death.



### **High Pressure Hazard**

The hydraulic system pressure must be relieved before disconnecting any hydraulic components or serious injury or death may occur.

For trailer shipping purposes, a check valve (810-037C), and two adapters (841-204C) (811-133C), have been installed to the outer left-and-right side hydraulic lift cylinders located on the center frame. It is necessary to remove these two check valves and four adapters from lift hydraulic cylinders upon delivery.

Once these parts have been removed from the lift hydraulic system, they should be retained for future shipping use. These parts must be installed on the planter lift hydraulics before any future trailer shipping.

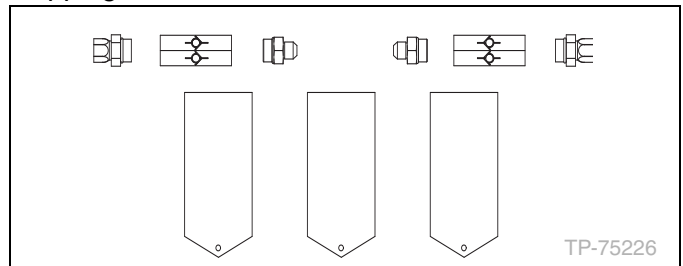

## With IntelliAg ISO6

To remove check valve:

1. With your in-cab console, tap the Fold Sequence softkey from the Home screen.

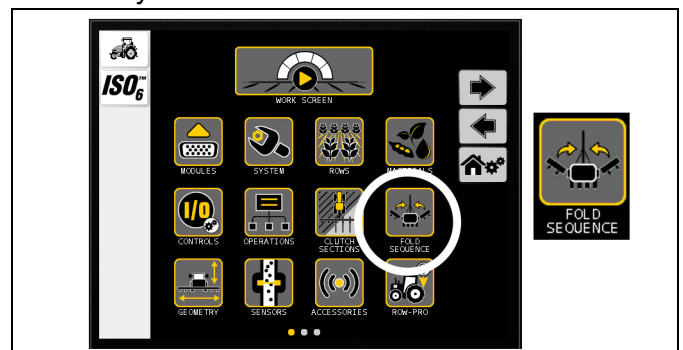

- Tap the Center Lift softkey to set the center lift hydraulic system to active. This is indicated by the Center Lift softkey changing to a blue Active Center Lift softkey.

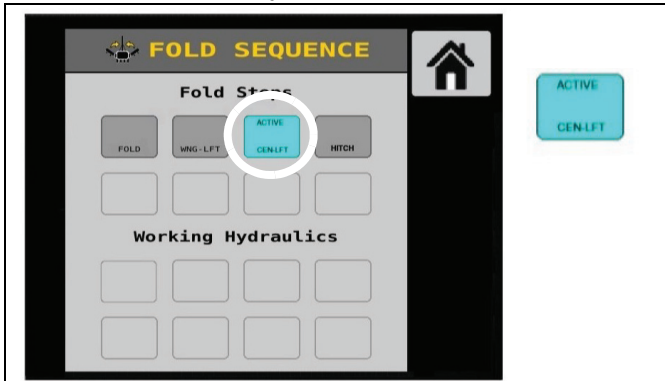

- Use tractor lift circuit lever to lower the center of the planter.
- Set tractor lift circuit lever to "Neutral".
- Tap the Active Center Lift softkey so the center lift hydraulic system is no longer active.

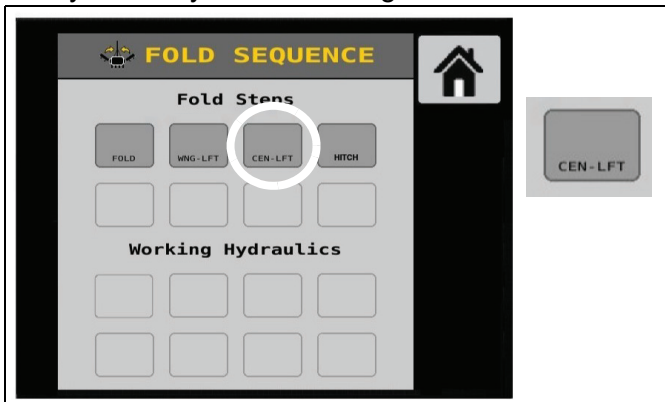

- Relieve hydraulic pressure.
- Set parking brake, turn off tractor, and remove key.
- On the outer left-side hydraulic lift cylinder, locate the check valve and adapters connected the lift cylinder rod-end.

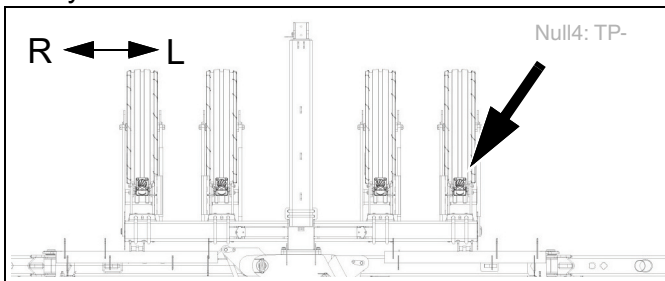

- Disconnect the hydraulic hose attached to the check valve (1) and the two adapters (2) on the rod-end (A) of the lift hydraulic cylinder. Use a

small container to capture any fluid. Be sure to protect the hose end to prevent system contamination from dirt and debris.

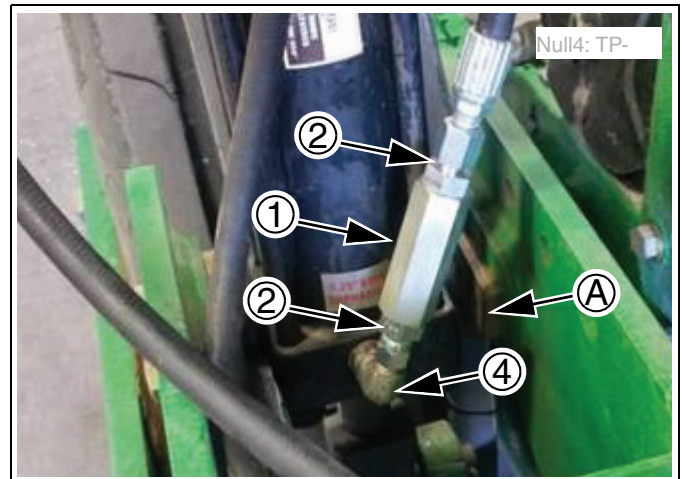

It is not necessary to remove the elbow fitting (4) located on the rod-end of the lift hydraulic cylinder.

- Disconnect the check valve (1) and the two adapters (2) from the elbow fitting (A) of the lift hydraulic cylinder. Set aside parts for future use.
- Connect the hydraulic hose (3) to the elbow fitting (4) on the rod-end of the lift hydraulic cylinder (5).

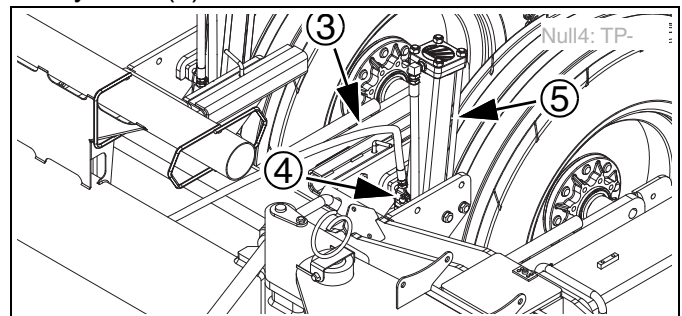

- Wipe away any excess hydraulic fluid from the planter.
- Repeat steps 9 through 12 on the outer right-side hydraulic lift cylinder.

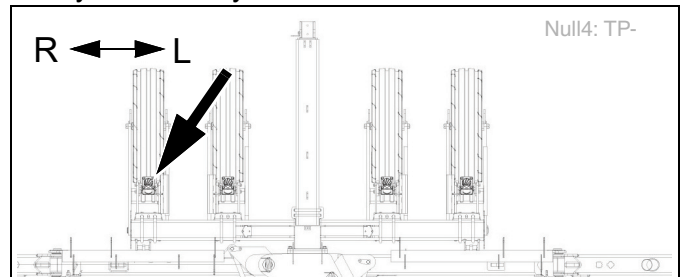

14. Once you have removed the two check valves, and four adapters, on both the left-and-right sides, slowly cycle the lift hydraulic system multiple times to rephase the cylinders. This will purge small amounts of air out of the system until smooth, even hydraulic movements are achieved. See **“Rephasing Hydraulics”** on page 14.

**With Switch Box**

To remove check valve:

1. One the switch box, toggle the on/off power switch to *ON*.



2. On the switch box, toggle the marker/fold switch to *MARKER*.



3. On the switch box, toggle the lift switch to the position *CENTER*.



4. Use the tractor lift circuit lever to lower the center frame of the planter.
5. Set tractor lift circuit lever to “Neutral”.
6. Relieve hydraulic pressure.
7. Set parking brake, turn off tractor, and remove key.

8. On the outer left-side hydraulic lift cylinder, locate the check valve and adapters connected the lift cylinder rod-end.

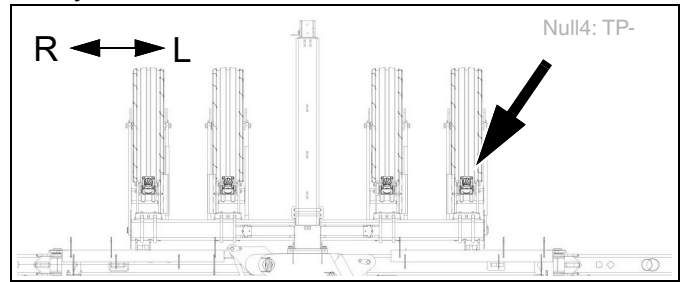

9. Disconnect the hydraulic hose attached to the check valve (1) and the two adapters (2) on the rod-end (A) of the lift hydraulic cylinder. Use a small container to capture any fluid. Be sure to protect the hose end to prevent system contamination from dirt and debris.

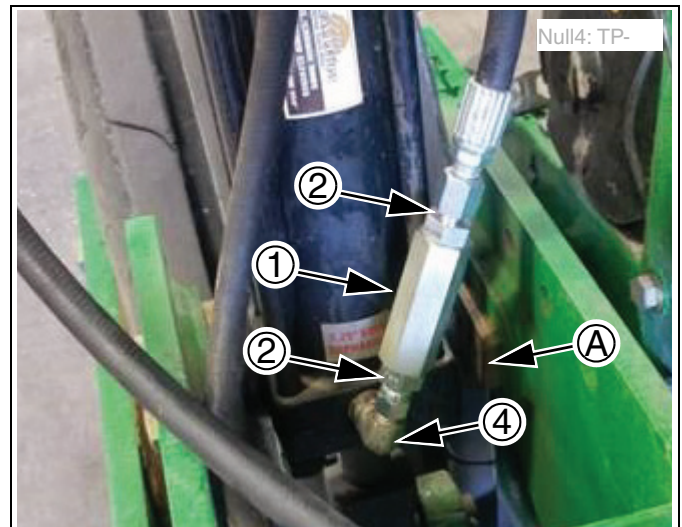

It is not necessary to remove the elbow fitting (4) located on the rod-end of the lift hydraulic cylinder.

10. Disconnect the check valve (1) and the two adapters (2) from the elbow fitting on the rod-end (A) of the lift hydraulic cylinder. Set aside parts for future use.

11. Connect the hydraulic hose (3) to the elbow fitting (4) on the rod-end of the lift hydraulic cylinder (5).

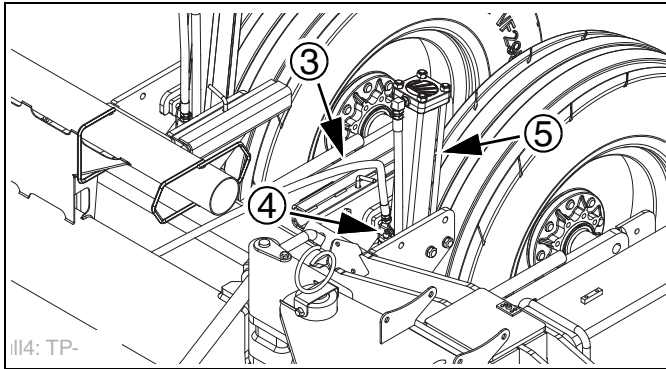

12. Wipe away any excess hydraulic fluid from the planter.

13. Repeat steps 9 through 12 on the outer right-side hydraulic lift cylinder.

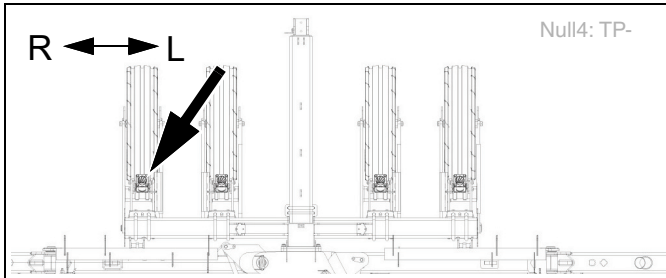

14. Once you have removed the two check valves, and four adapters, on both the left-and-right sides, slowly cycle the lift hydraulic system multiple times to rephase the cylinders. This will purge small amounts of air out of the system until smooth, even hydraulic movements are achieved. See “**Rephasing Hydraulics**” on page 14.

### ■ Shipping Chain Removal



**High Pressure Fluid Hazard**

*Escaping fluid under pressure can have sufficient pressure to penetrate the skin. Use care to not cut, pinch, or otherwise damage hydraulic lines and fittings while completing tasks in this area. If injured, seek immediate medical attention from a physician familiar with this type of injury.*



**Planter Damage Risk**

*Do not attempt to unfold the planter until the shipping chain or strap have been removed. Serious planter damage will occur if the fold hydraulic system is operated while the tongue*

*shipping chain or strap is installed. It must be removed from the planter.*

1. Carefully remove the shipping or strap binding the left-and-right wings to the tongue.

### ■ Close-Out

- ☑ Ensure all moving parts are moving freely, bolts are tighten to torque, and cotter pins are spread.
- ☑ Remove any shipping tags.
- ☑ Remove all tools, equipment, and supplies from work area.
- ☑ Check for proper tension and alignment on all drive chains.
- ☑ Inflate tires to recommended pressure as listed on “**Tire Information**” on page 118.
- ☑ Tighten wheel bolts to torque as specified on “**Torque Value Chart**” on page 118.

# Trailer Shipping



**High Pressure Fluid Hazard**

Escaping fluid under pressure can have sufficient pressure to penetrate the skin. Check all hydraulic lines and fittings before applying pressure. Use paper or cardboard, not body parts, and wear heavy gloves to check for suspected leaks. If injured, seek immediate medical attention from a physician familiar with this type of injury.



**High Pressure Hazard**

The hydraulic system pressure must be relieved before disconnecting any hydraulic components or serious injury or death may occur.



**Crushing Hazard**

Failure to install the shipping check valve kit prior to trailer transport can result in the planter becoming unbalanced. A falling planter can cause severe injury or death.



**Flailing Hazard**

Marker hydraulics are active whenever the fold hydraulics are not in use. It is important to set the tractor fold/marker hydraulic circuit lever to “Float” or “Neutral” to prevent unintended marker operations. Unexpected marker operation and flailing equipment can seriously injure including death.



**Equipment Damage Risk**

Do not ship planter on trailer without installing the check valve shipping kit or severe equipment damage can occur.

This section provides information for a trained professional to prepare the planter for trailer transport. A check valve shipping kit will need to be installed before trailer transport. Contact your Great Plains dealer for professional installation.

The instructions in this section are not intended for customer use.

**Do not trailer the planter without completing the following tasks:**

- ☑ Read and understand the instructions in this section - **Trailer Shipping.**
- ☑ Secure wings to the tongue with a properly rated shipping chain or strap.
- ☑ Professionally installed check valve shipping kit.
- ☑ Comply with all local, regional, and national shipping and transportation regulations.

## Shipping Chain Installation



**Pinch Point and Crushing Hazards**

Moving parts can pinch or crush causing serious injury or death. Distance between tractor and planter will decrease when unfolding and increase when folding. Keep all persons away when fold or unfolding the planter.



**Tire Damage Risk**

Ensure the tractor gear is set to “Neutral” before folding/unfolding operations to avoid damages to the tires.



**Frame Damage Risk**

Do not fold/unfold without first fully raising the planter completely or frame damage will occur.



**Frame Damage Risk**

Do not raise/lower the wing gauge wheels at any time once the shipping chain has been installed. While the shipping chain is installed the planter lift hydraulic system should only be operated as “Center” or “Center Lift” or planter frame damage can occur.

It is strongly recommended, the planter wings are secured to the tongue with a properly installed shipping chain or strap.

### With IntelliAg ISO6

1. Move the planter to level ground with adequate overhead and side-to-side clearance for the fold operation.
2. If installed, ensure markers are folded.
3. As installed, set tractor circuit levers for the fan(s) and hydraulic drive to “Neutral”.
4. Use tractor lift circuit lever to fully raise the planter.
5. Set tractor lift circuit lever to “Neutral”.
6. Set tractor gear to “Neutral”.
7. With your in-cab console, tap the Fold Sequence softkey from the Home screen.

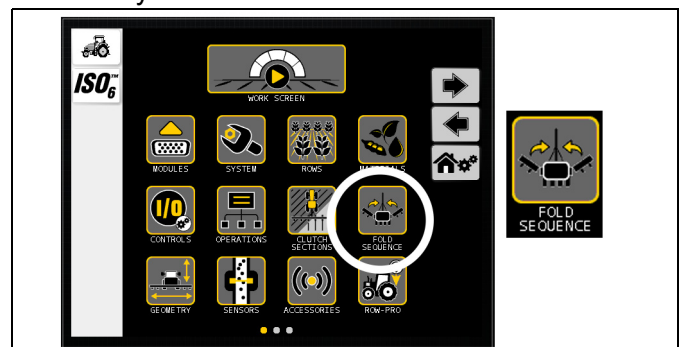

- Tap the Wing Lift softkey to set the wing lift hydraulic system to active. This is indicated by the Wing Lift softkey changing to a blue Active Wing Lift softkey.

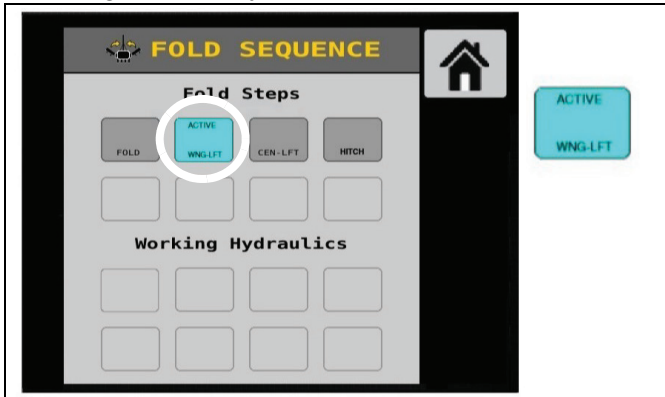

- Use the tractor lift circuit lever to raise the wing gauge wheels.
- When the wing gauge wheels are raised, tap the Active Wing Lift softkey so wing lift hydraulic system is no longer active.

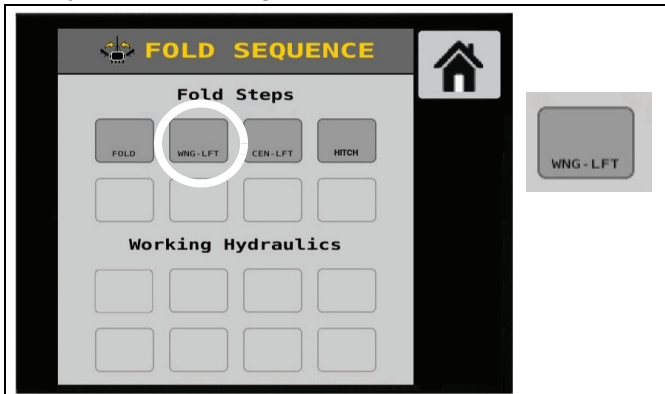

- Set tractor lift circuit lever to "Neutral".
- Tap the Fold softkey to set the Fold hydraulic system to active. This is indicated by the Fold softkey changing to a blue Active Fold softkey.

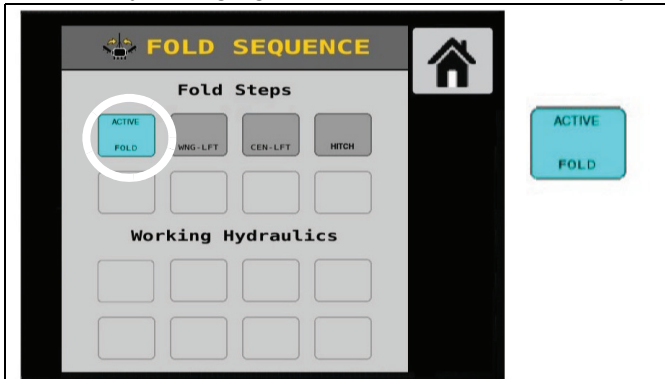

- Use tractor fold circuit lever until the planter is fully folded.

- Set the fold hydraulic circuit to "Neutral".
- When folding is complete, tap the Active Fold softkey so fold hydraulic system is no longer active.

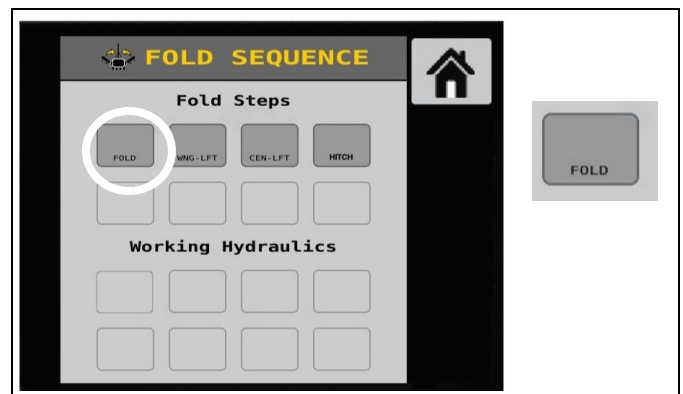

- Set the tractor circuit lever to "Neutral".
- Set the parking brake.
- Set the tractor gear to "Park".
- Install cylinder locks on the four lift hydraulic cylinders on the center frame.

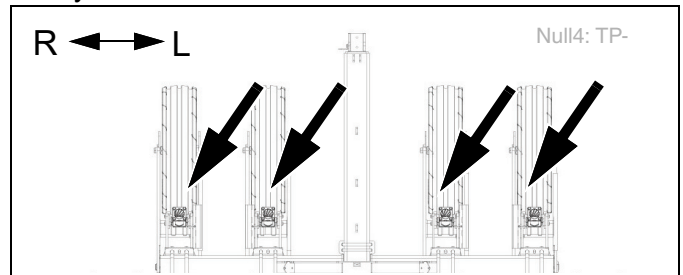

- Verify the wing hooks are resting on tongue stop.

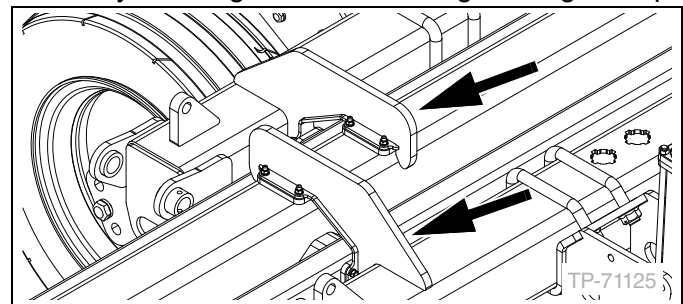

- Set tractor hydraulic circuits to "Neutral".
- Secure the wings to the tongue with a properly rated shipping chain or strap.

**With Switch Box**



**Frame Damage Risk**

Do not raise/lower the wing gauge wheels at any time once the shipping chain has been installed. While the shipping chain is installed the planter lift hydraulic system should only be operated as "Center" or "Center Lift" or planter frame damage can occur.

1. Move the planter to level ground with adequate overhead and side-to-side clearances for the fold operation.
2. If installed, remove cylinder locks and stow in storage position.

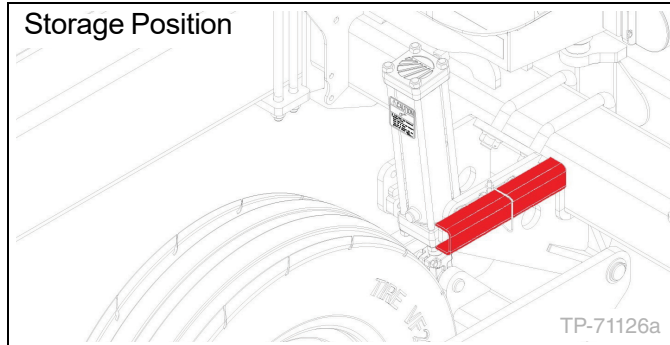

3. If installed, ensure markers are folded.
4. As equipped, set tractor circuit levers for the fan(s) and hydraulic drive to "Neutral".
5. Set the tractor gear to "Neutral".
6. Fully lower the two-point hitch.
7. On the switch box, toggle the on/off power switch to ON.



8. On the switch box, toggle the marker/fold switch to *MARKER*.



9. On the switch box, toggle the lift switch to the center position *WHEELS*.



10. Use tractor lift circuit lever to fully raise the planter.
11. Set the tractor circuit lever to "Neutral".
12. On the switch box, toggle the lift switch to *WING*.



13. Use tractor lift circuit lever to raise the wing gauge wheels.
14. Set the lift hydraulic circuit to "Neutral".
15. On the switch box, toggle the lift switch to the center position *WHEELS*.



16. Use the tractor lift circuit lever to fully raise the planter.
17. Set tractor fold circuit lever to "Neutral".
18. Set tractor gear to "Neutral".

19. On the switch box, toggle the marker/fold switch to **FOLD**.



- 20. Use the tractor fold circuit lever to fold the planter.
- 21. Set tractor hydraulic circuits to “Neutral”.
- 22. Set the parking brake.
- 23. Set tractor gear to “Park”.
- 24. Verify the wing hooks are resting on tongue stop.

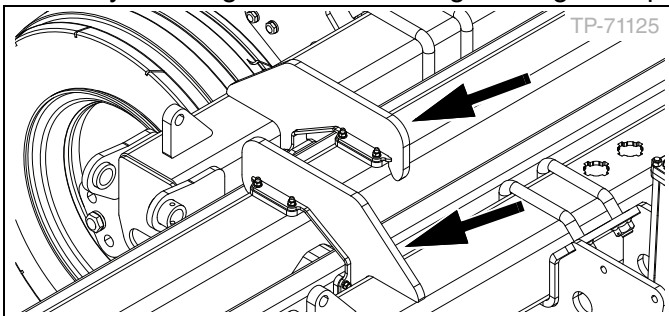

25. Secure the wings to the tongue with a properly rated shipping chain or strap.

### ■ Shipping Check Valve Kit Installation

Installation of the shipping check valve kit will prevent the planter from becoming unbalanced during loading, unloading, and trailer transport.

The shipping check valve kit will need to be installed on the outer left-and-right side hydraulic lift cylinders located on the center frame.

A new kit may be ordered from any Great Plains dealer.

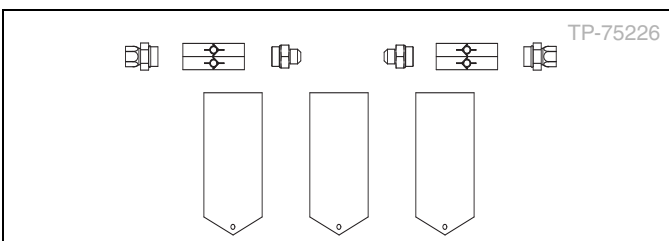

The planter should already be folded for transport and have the provisioned shipping chain or strap installed.

### With IntelliAg ISO6



#### Frame Damage Risk

*Do not raise/lower the wing gauge wheels at any time once the shipping chain has been installed. Do not attempt to unfold the planter while the shipping chain is installed. While the shipping chain is installed the planter lift hydraulic system should only be operated as “Center” or “Center Lift” or planter frame damage can occur.*

#### To install a check valve:

1. If installed, remove cylinder locks and stow in storage position.

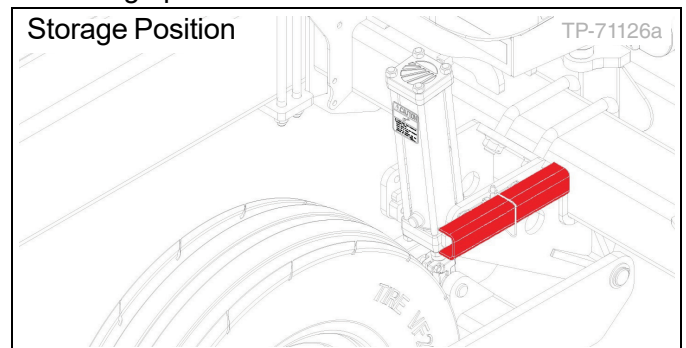

2. With your in-cab console, tap the Fold Sequence softkey from the Home screen.

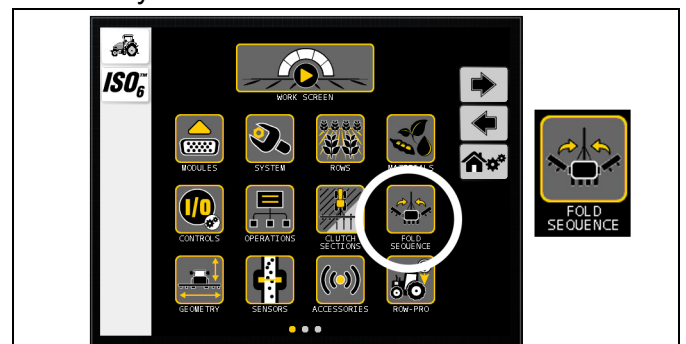

3. Tap the Center Lift softkey to set the center Lift hydraulic system to active. This is indicated by

the Wing Lift softkey changing to a blue Active Wing Lift softkey.

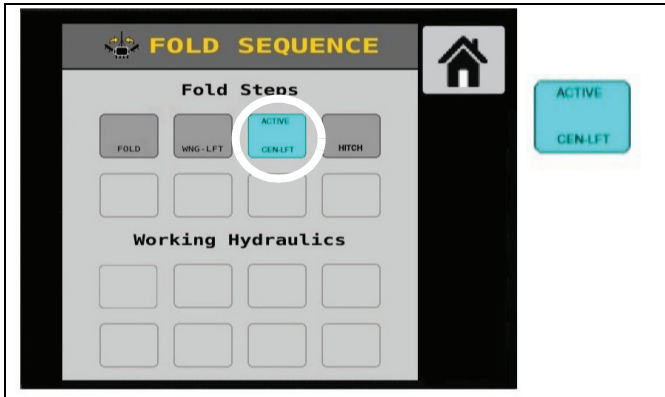

4. Use the tractor lift circuit lever to lower the center frame of the planter.
5. When the center frame of the planter is fully lowered, tap the Active Center Lift softkey so center lift hydraulic system is no longer active.

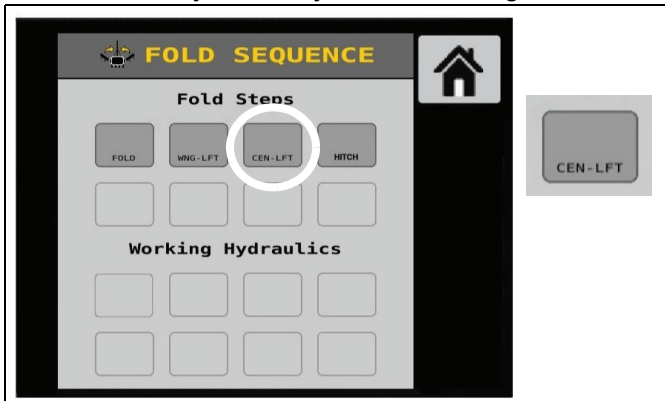

6. Set tractor lift circuit lever to "Neutral".
7. Relieve hydraulic pressure.
8. Set parking brake, set tractor gear in "Park", turn off tractor, and remove key.
9. Locate the left-side hydraulic lift cylinder.

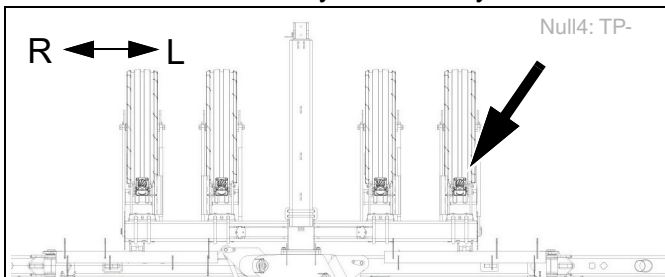

10. Disconnect the hydraulic hose (1) attached to an elbow fitting (2) on the hydraulic lift cylinder rod-

end (A). Use a small collection container to capture any fluid.

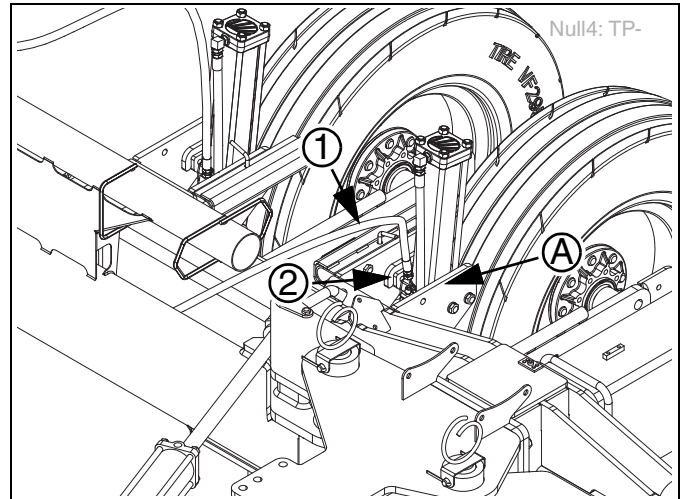

**Planter Damage Risk**

When installing the check valve note the orientation (B) as indicated the following illustration. Failure to install the check valve in the correct orientation will result in significant planter damage from an unbalanced planter at risk for toppling and falling.

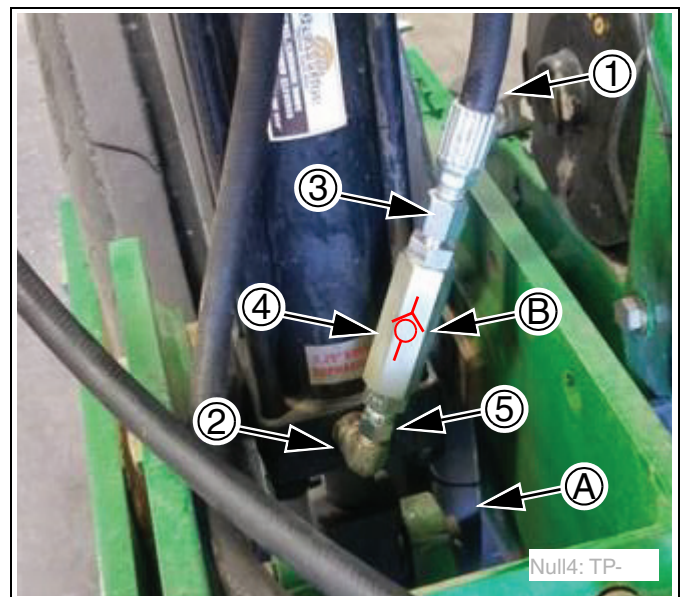

11. On the hydraulic hose (1), attach the adapter (3), check valve (4) in the correct orientation (B), and adapter (5). Then, attach adapter (5) to the elbow fitting (2) on the rod-end (A) on the hydraulic cylinder.

12. Wipe down any hydraulic fluid on the planter.

13. Attach a shipping caution tag (6) on the hydraulic cylinder.

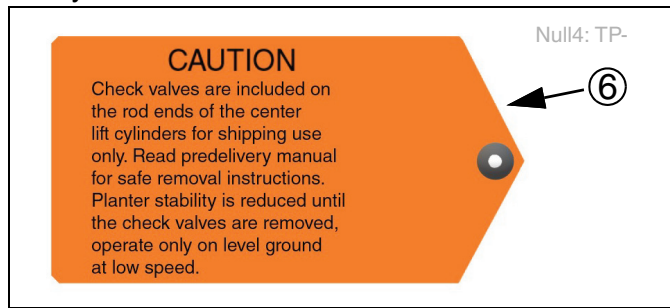

14. Repeat steps 10 through 13 on the outer right-side hydraulic lift cylinder.

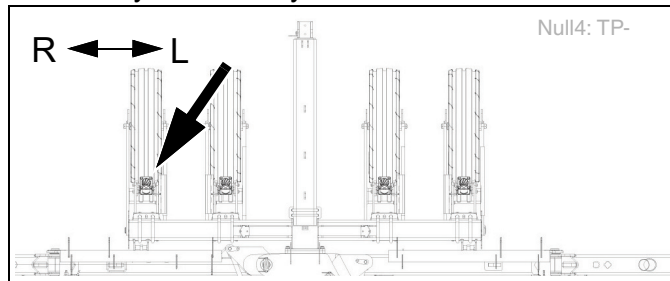

**With Switch Box**



**Frame Damage Risk**

Do not raise/lower the wing gauge wheels at any time once the shipping chain has been installed. While the shipping chain is installed the planter lift hydraulic system should only be operated as "Center" or "Center Lift" or planter frame damage can occur.

To install a check valve:

1. If installed, remove cylinder locks and stow in storage position.

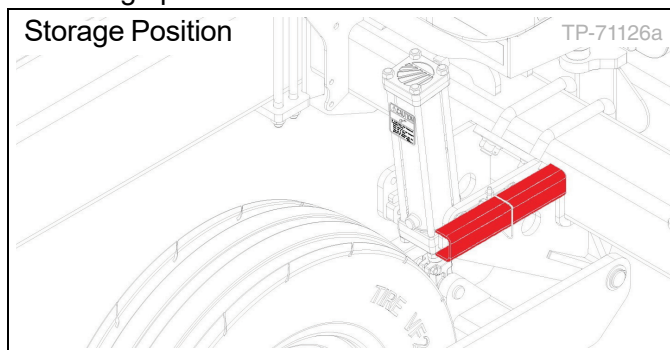

2. On the switch box, toggle the on/off power switch to ON.

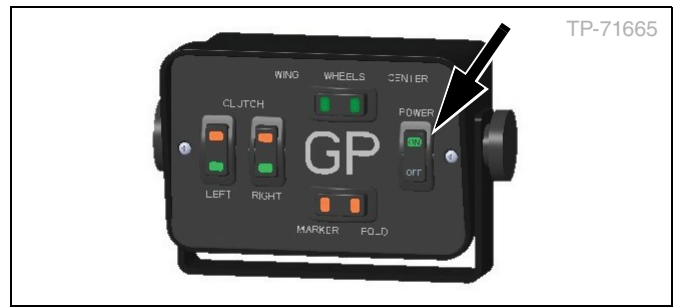

3. On the switch box, toggle the marker/fold switch to MARKER.



4. On the switch box, toggle the lift switch to the position CENTER.



5. Use the tractor lift circuit lever to lower the center frame of the planter.

6. Set tractor lift circuit lever to "Neutral".

7. Relieve hydraulic pressure.

8. Set tractor gear in "Park", set park brake, turn off tractor, and remove key.

9. Locate the left-side hydraulic lift cylinder.

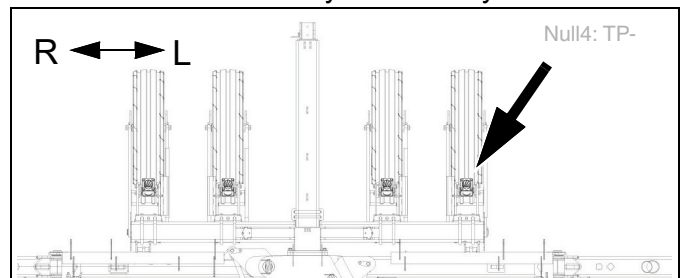

10. Disconnect the hydraulic hose (1) attached to an elbow fitting (2) on the hydraulic lift cylinder rod-end (A). Use a small collection container to capture any fluid.

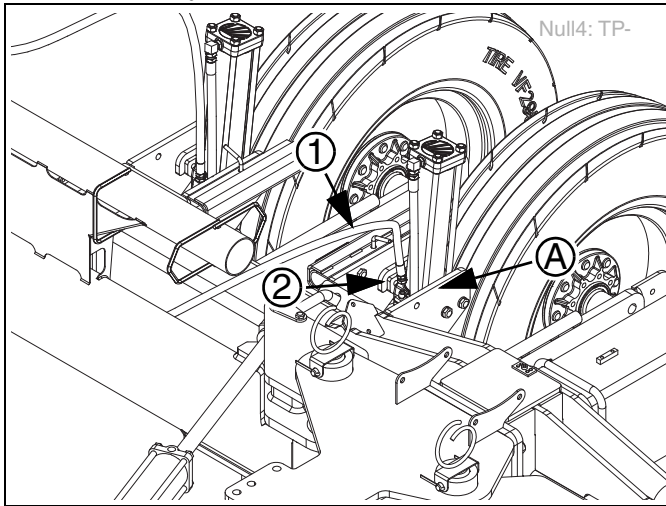

**Planter Damage Risk**

When installing the check valve note the orientation (B) as indicated the following illustration. Failure to install the check valve in the correct orientation will result in significant planter damage from an unbalanced planter at risk for toppling and falling.

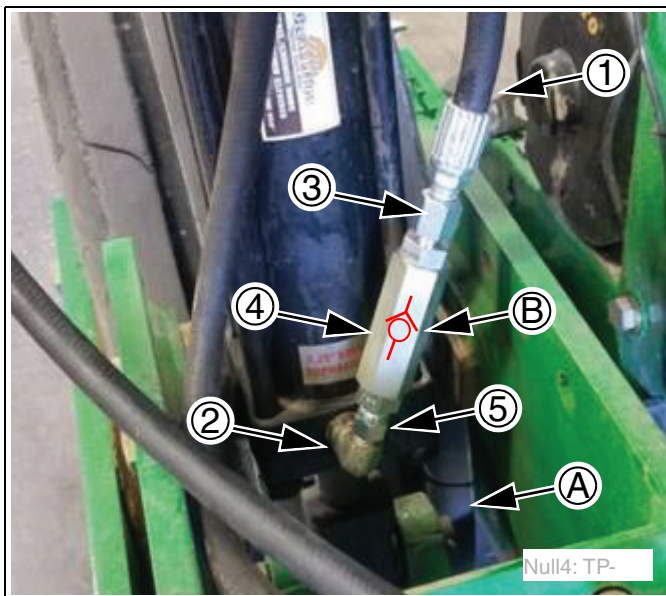

11. On the hydraulic hose (1), attach the adapter (3), check valve (4) in the correct orientation (B), and adapter (5). Then, attach adapter (5) to the elbow fitting (2) on the rod-end (A) on the hydraulic cylinder.

12. Wipe down any hydraulic fluid on the planter.

13. Attach a shipping caution tag (6) on the hydraulic cylinder.

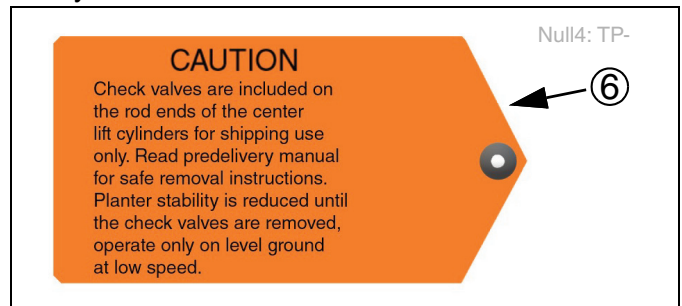

14. Repeat steps 10 through 13 on the outer right-side hydraulic lift cylinder.

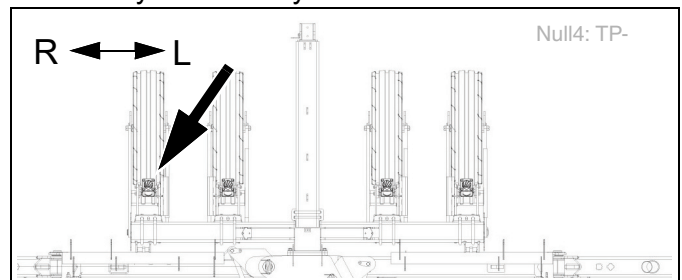

**Close-Out**

Once the shipping check valve kit has been installed, the planter should only be operated for the purpose of trailer loading. Your hydraulic pressure should be at the lowest pressure. Hydraulic movements should be slow and careful to produce smooth, even hydraulic movements.

Before operating the planter:

- Remove all tools, parts, materials, and debris from the work area.
- Wipe down any hydraulic fluid and clean-up any spills.

**■ Loading Planter on Trailer**



**Crushing Hazard**

Failure to follow these trailer loading and unloading procedures can result in the planter becoming unbalanced. A falling planter can cause severe injury or death.



**Frame Damage Risk**

Do not raise/lower the wing gauge wheels at any time once the shipping chain has been installed. While the shipping chain is installed the planter lift hydraulic system should only be operated as "Center" or "Center Lift" or planter frame damage can occur.

With IntelliAg ISO6

1. With your in-cab console, tap the Fold Sequence softkey from the Home screen.

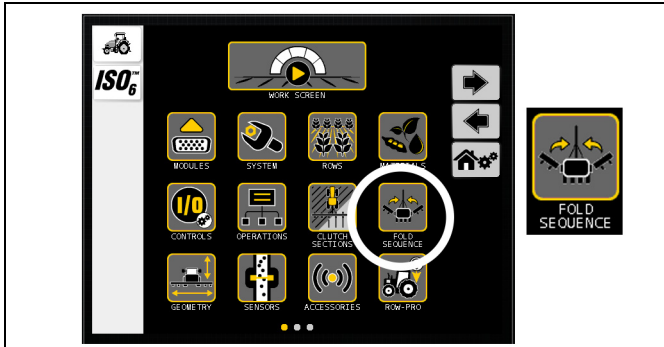

2. Tap the Center Lift softkey to set the center lift hydraulic system to active. This is indicated by the Center Lift softkey changing to a blue Active Center Lift softkey.

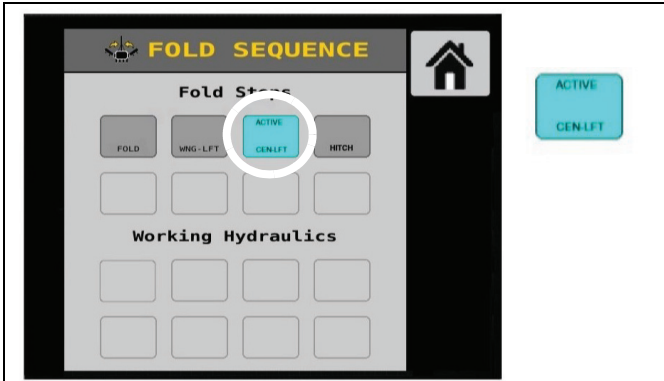

3. Use tractor lift circuit lever to raise the center of the planter.
4. Set tractor lift circuit lever to "Neutral".
5. Using caution and care, pull the planter slowly onto the trailer bed.
6. Use the tractor circuit lift lever to slowly lower the planter on to the trailer bed.
7. Tap the Active Center Lift softkey so the center lift hydraulic system is no longer active.

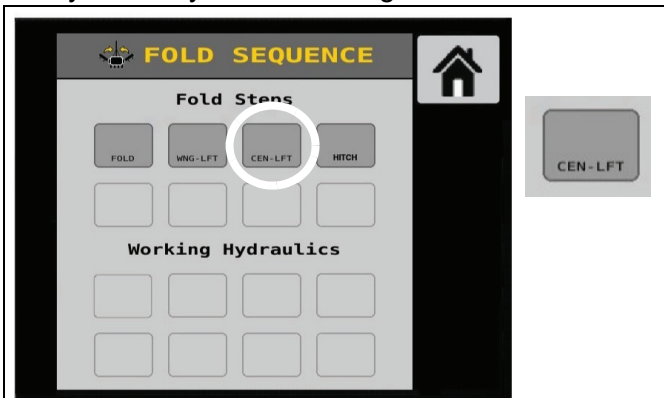

8. Relieve hydraulic pressure.
9. Set the parking brake, turn off the tractor, and remove the key.
10. Set the parking stands.
11. Disconnect hydraulics, electrical harnesses and consoles, and unhitch the planter.
12. Slowly move tractor from shipping area.
13. Secure the planter to trailer.
14. Comply with local, regional, and national transport standards and requirements.

**With Switch Box**

1. One the switch box, toggle the on/off power switch to ON.



2. On the switch box, toggle the marker/fold switch to **MARKER**.



3. On the switch box, toggle the lift switch to the position **CENTER**.



4. Use the tractor lift circuit lever to lower the center frame of the planter.
5. Set tractor lift circuit lever to "Neutral".
6. Using caution and care, pull the planter slowly onto the trailer bed.

7. Use the tractor circuit lift lever to slowly lower the planter on the trailer bed.
8. Relieve hydraulic pressure.
9. Set tractor gear in “Park”, set park brake, turn off tractor, and remove key.
10. Set the parking stands.
11. Disconnect hydraulics, electrical harnesses and consoles, and unhitch the planter.
12. Slowly move tractor from shipping area.
13. Secure the planter to trailer.
14. Comply with local, regional, and national transport standards and requirements.

**■ Unloading from Trailer**



**Secure Machine**

*It is necessary for the shipping chain or strap securing the wings to the tongue remains in place until the planter has been unloaded from the trailer. The shipping chain or strap should not secure any part of the planter to the trailer. Failure to keep shipping chain or strap secured during unloading can result in the planter becoming unbalanced. A falling planter can cause severe injury or death.*



**High Pressure Fluid Hazard**

*Escaping fluid under pressure can have sufficient pressure to penetrate the skin. Check all hydraulic lines and fittings before applying pressure. Use paper or cardboard, not body parts, and wear heavy gloves to check for suspected leaks. If injured, seek immediate medical attention from a physician familiar with this type of injury.*



**Frame Damage Risk**

*Do not raise/lower the wing gauge wheels at any time with shipping chain or strap installed on tongue. Do not attempt to unfold the planter while the shipping chain is installed. While the shipping chain is installed the planter lift hydraulic system should only be operated as “Center” or “Center Lift” or planter frame damage can occur.*

**With IntelliAg ISO6**

1. Ensure all chain and tie-down straps have been released and stowed. Do not remove the tongue shipping chain or strap securing the wings to the tongue.
2. Move the tractor close to the planter hitch.
3. Adjust the tractor 3-point arms and sway blocks to minimize side-to-side sway when transporting. See your tractor’s operator manual for information.

4. Raise the hitch height high enough to clear the drawbar.
5. Back the tractor to align the drawbar and hitch.
6. Connect the tractor to the planter. If using a quick hitch, ensure the planter locks into the hitch securely.
7. Raise the hitch high enough to take pressure off the parking stands.
8. Remove each pin (1) and slide up the parking stand.

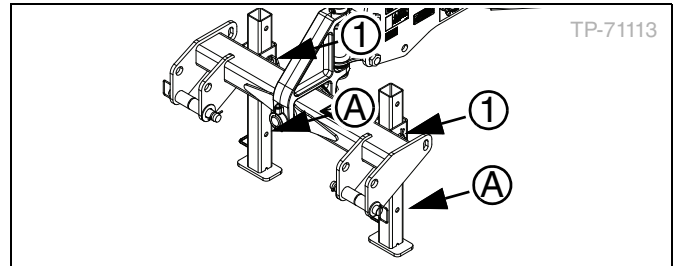

9. Install the pins (1) in the bottom hole (A) of the parking stands.
10. Make lift hydraulic connections from tractor circuit to planter.
11. Make all electrical connections from planter to tractor.
12. With your in-cab console, tap the Fold Sequence softkey from the Home screen.



13. Tap the Center Lift softkey to set the center lift hydraulic system to active. This is indicated by

the Center Lift softkey changing to a blue Active Center Lift softkey.

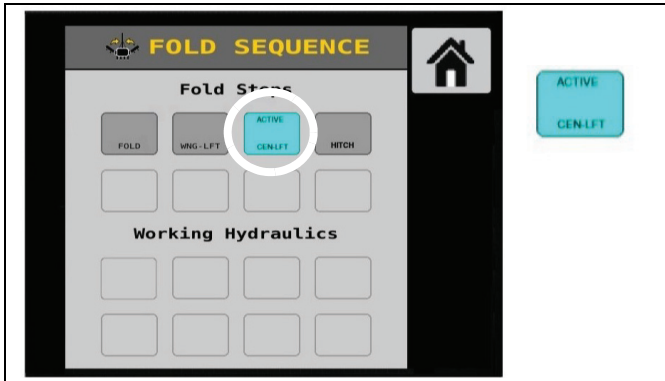

14. Use tractor lift circuit lever to raise the center of the planter.
15. Set tractor lift circuit lever to "Neutral".
16. Install cylinder locks.



17. Using caution and care, pull the planter slowly off the trailer bed.
18. Set tractor lift circuit lever to "Neutral".
19. Remove cylinder locks and stow in storage position.

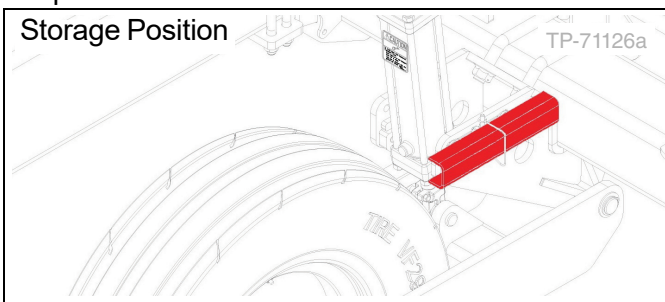

20. Use the tractor circuit lift lever to slowly lower the planter to the ground.
21. Set tractor lift circuit lever to "Neutral".

22. Tap the Active Center Lift softkey so the center lift hydraulic system is no longer active.

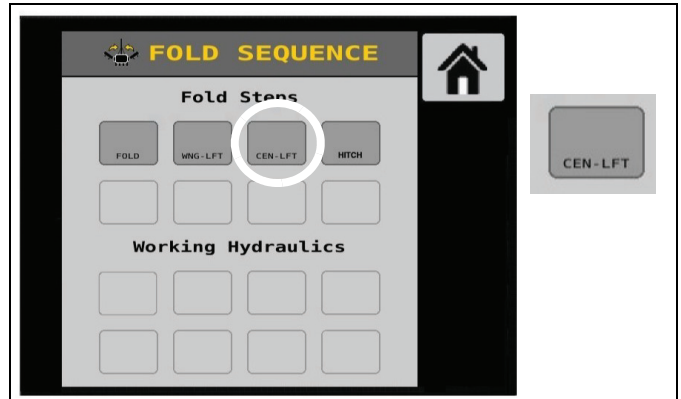

**With Switch Box**

1. Ensure all chain and tie-down straps have been released and stowed. Do not remove the tongue shipping chain or strap securing the wings to the tongue.
2. Move the tractor close to the planter hitch.
3. Adjust the tractor 3-point arms and sway blocks to minimize side-to-side sway when transporting. See your tractor's operator manual for information.
4. Raise the hitch height high enough to clear the drawbar.
5. Back the tractor to align the drawbar and hitch.
6. Connect the tractor to the planter. If using a quick hitch, ensure the planter locks into the hitch securely.
7. Raise the hitch high enough to take pressure off the parking stands.
8. Remove each pin (1) and slide up the parking stand.

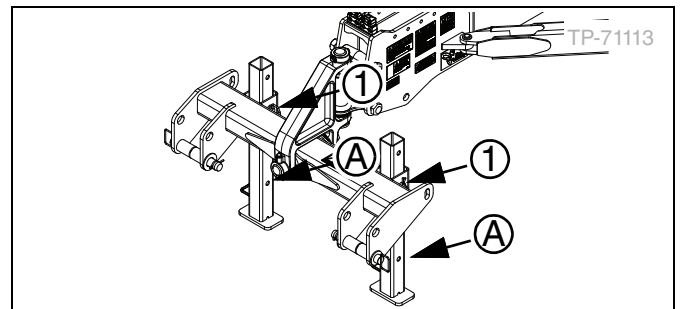

9. Install the pins (1) in the bottom hole (A) of the parking stands.
10. Make lift hydraulic connections from tractor circuit to planter.
11. Make all electrical connections from planter to tractor.

12. On the switch box, toggle the on/off power switch to ON.



13. On the switch box, toggle the marker/fold switch to MARKER.



14. On the switch box, toggle the lift switch to the position CENTER.



15. Use the tractor lift circuit lever to raise the center frame of the planter.  
 16. Set tractor lift circuit lever to "Neutral".  
 17. Install cylinder locks.



18. Using caution and care, pull the planter slowly off the trailer bed.

19. Set tractor lift circuit lever to "Neutral".  
 20. Remove cylinder locks and stow in storage position.

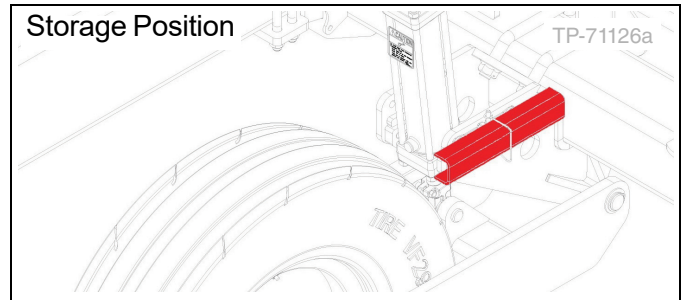

21. Use the tractor circuit lift lever to slowly lower the planter to the ground.  
 22. Set tractor lift circuit lever to "Neutral".

**Shipping Check Valve Removal**



**High Pressure Fluid Hazard**

Do not attempt to make hydraulic system repairs. Great Plains strongly recommends that all hydraulic system repairs to be completed by a trained professional who is knowledgeable about how to safely complete hydraulic system work. You should only maintain or adjust your hydraulic system as described within this manual. Compromising a closed hydraulic system can cause serious injury or death.



**High Pressure Hazard**

The hydraulic system pressure must be relieved before disconnecting any hydraulic components or serious injury or death may occur.



**Frame Damage Risk**

Do not raise/lower the wing gauge wheels at any time with shipping chain or strap installed on tongue. Do not attempt to unfold the planter while the shipping chain is installed. While the shipping chain is installed the planter lift hydraulic system should only be operated as "Center" or "Center Lift" or planter frame damage can occur.

**With IntelliAg ISO6**

**To remove check valve:**

1. With your in-cab console, tap the Fold Sequence softkey from the Home screen.

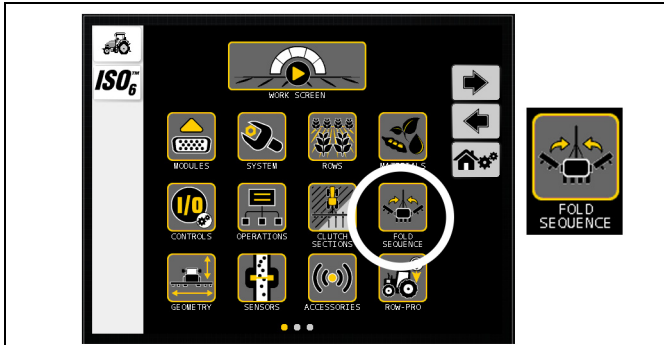

2. Tap the Center Lift softkey to set the center lift hydraulic system to active. This is indicated by the Center Lift softkey changing to a blue Active Center Lift softkey.

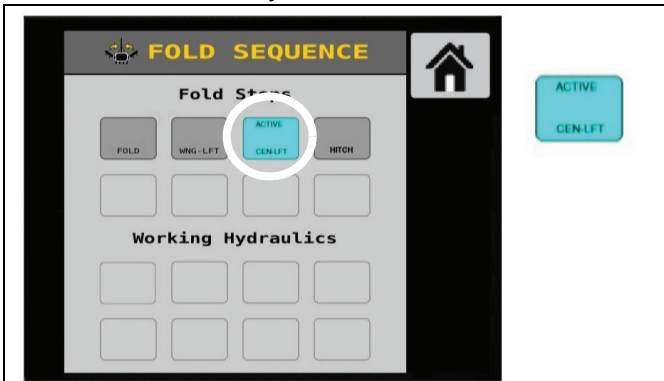

3. Use tractor lift circuit lever to lower the center of the planter.
4. Set tractor lift circuit lever to "Neutral".
5. Tap the Active Center Lift softkey so the center lift hydraulic system is no longer active.

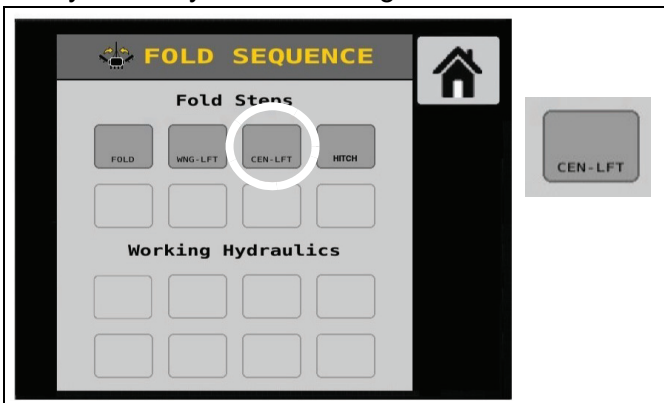

6. Relieve hydraulic pressure.

7. Set parking brake, turn off tractor, and remove key.
8. On the outer left-side hydraulic lift cylinder, locate the check valve and adapters connected the lift cylinder rod-end.

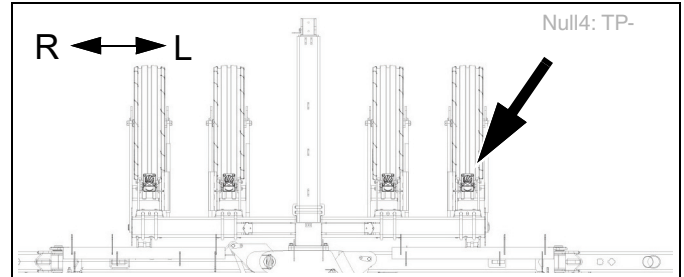

9. Disconnect the hydraulic hose attached to the check valve (1) and the two adapters (2) on the rod-end (A) of the lift hydraulic cylinder. Use a small container to capture any fluid. Be sure to protect the hose end to prevent system contamination from dirt and debris.

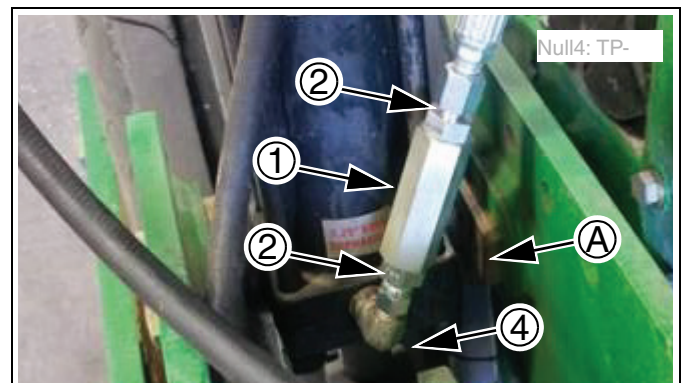

It is not necessary to remove the elbow fitting (4) located on the rod-end of the lift hydraulic cylinder.

10. Disconnect the check valve (1) and the two adapters (2) from the elbow fitting on the rod-end (A) of the lift hydraulic cylinder. Set aside parts for future use.
11. Connect the hydraulic hose (3) to the elbow fitting (4) on the rod-end of the lift hydraulic cylinder (5).

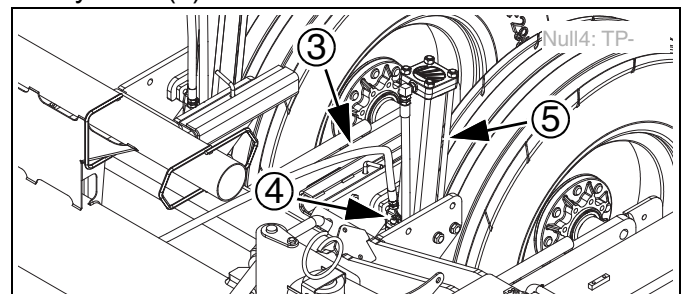

- Wipe away any excess hydraulic fluid from the planter.
- Repeat steps 9 through 12 on the outer right-side hydraulic lift cylinder.

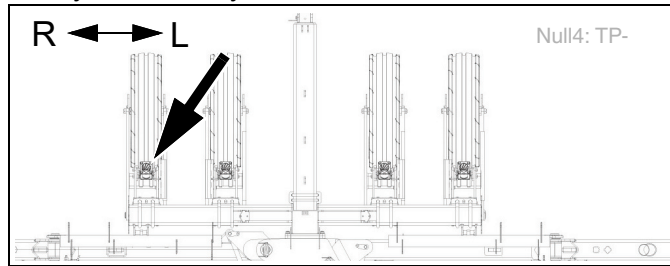

- Once you have removed the two check valves, and four adapters, on both the left-and-right sides, slowly cycle the lift hydraulic system multiple times to rephase the cylinders. This will purge small amounts of air out of the system until smooth, even hydraulic movements are achieved. See **“Rephasing Hydraulics”** on page 14.

**With Switch Box**

To remove check valve:

- On the switch box, toggle the on/off power switch to **ON**.



- On the switch box, toggle the marker/fold switch to **MARKER**.



- On the switch box, toggle the lift switch to the position **CENTER**.



- Use the tractor lift circuit lever to lower the center frame of the planter.
- Set tractor lift circuit lever to “Neutral”.
- Relieve hydraulic pressure.
- Set parking brake, turn off tractor, and remove key.
- On the outer left-side hydraulic lift cylinder, locate the check valve and adapters connected the lift cylinder rod-end.

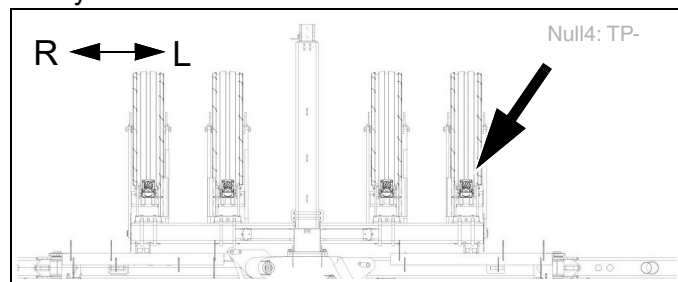

- Disconnect the hydraulic hose attached to the check valve (1) and the two adapters (2) on the rod-end (A) of the lift hydraulic cylinder. Use a small container to capture any fluid. Be sure to protect the hose end to prevent system contamination from dirt and debris.

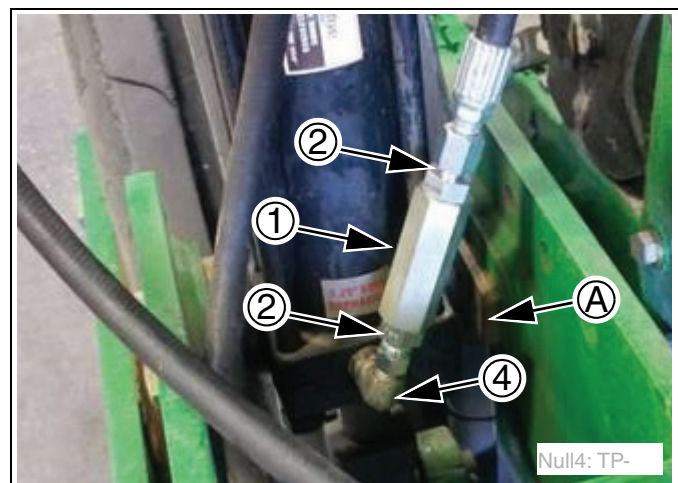



It is not necessary to remove the elbow fitting (4) located on the rod-end of the lift hydraulic cylinder.

10. Disconnect the check valve (1) and the two adapters (2) from the elbow fitting on the rod-end (A) of the lift hydraulic cylinder. Set aside parts for future use.
11. Connect the hydraulic hose (3) to the elbow fitting (4) on the rod-end of the lift hydraulic cylinder (5).

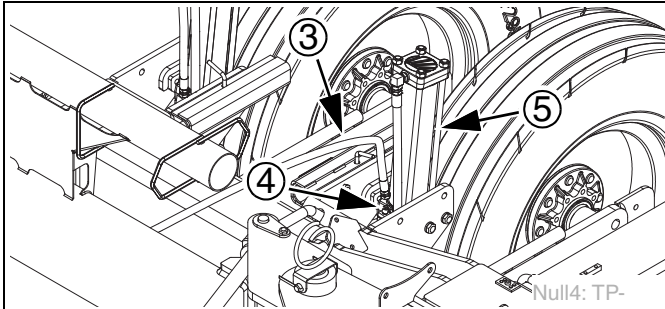

12. Wipe away any excess hydraulic fluid from the planter.
13. Repeat steps 9 through 12 on the outer right-side hydraulic lift cylinder.

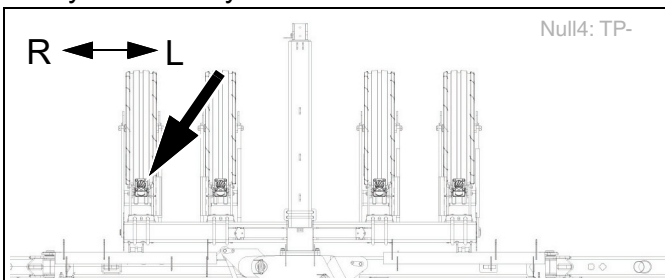

14. Once you have removed the two check valves, and four adapters, on both the left-and-right sides, slowly cycle the lift hydraulic system multiple times to rephase the cylinders. This will purge small amounts of air out of the system until smooth, even hydraulic movements are achieved. See “Rephasing Hydraulics” on page 14.

## ■ Shipping Chain Removal



### **High Pressure Fluid Hazard**

Escaping fluid under pressure can have sufficient pressure to penetrate the skin. Use care to not cut, pinch, or otherwise damage hydraulic lines and fittings while completing tasks in this area. If injured, seek immediate medical attention from a physician familiar with this type of injury.



### **Secure Machine**

It is necessary for the shipping chain or strap securing the wings to the tongue to remain in place until the planter has been unloaded from the trailer. Do not attempt to unfold the planter when the shipping chain is installed. The shipping chain or strap should not secure any part of the planter to the trailer. Failure to keep shipping chain or strap secured during unloading can result in the planter becoming unbalanced. A falling planter can cause severe injury or death.

1. Carefully remove the shipping or strap binding the left-and-right wings to the tongue.

## ■ Close-Out

- Ensure all moving parts are moving freely, bolts are tighten to torque, and cotter pins are spread.
- Check for proper tension and alignment on all drive chains.
- Inflate tires to recommended pressure as listed on “**Tire Information**” on page 118.
- Tighten wheel bolts to torque as specified on “**Torque Value Chart**” on page 118.



## WARRANTY

Great Plains (a division of Great Plains Manufacturing, Inc.) warrants to the original purchaser that this Great Plains machine will be free from defects in material and workmanship for a period of one year (Parts & Labor) from the first use date when used as intended for personal use; ninety days for custom/commercial or rental use.

Second year limited warranty covers Parts ONLY (personal usage only, excluding labor and wear items). This warranty is limited to the replacement of any defective part by Great Plains. Great Plains reserves the right to inspect any equipment or part which are claimed to have been defective in material or workmanship.

The following items and/or conditions are **NOT COVERED UNDER WARRANTY:** Failures resulting from the abuse or misuse of the equipment, failures occurring as a result of accidental damage or Force Majeure, failures resulting from alterations or modifications, failures caused by lack of normal maintenance as outlined in the operator's manual, repairs made by non-authorized personnel, items replaced or repaired due to normal wear (such as wear items and ground-engaging components including, but not limited to, disc blades, chisel points, tires, bushings, and scrapers), repeat repair due to improper diagnosis or improper repair by the dealer, temporary repairs, service call and /or mileage to and from customer location, overtime premium, or unit hauling expenses. The warranty may be voided if the unit is towed at speeds in excess of 20 miles per hour (32 kilometers per hour), or failures occurring from soils with rocks, stumps, or other obstructions.

Great Plains reserves the right to make changes in materials or design of the product at any time without notice. The warranty shall not be interpreted to render Great Plains liable for damages of any kind, direct or consequential or contingent to property. Furthermore, Great Plains shall not be liable for damages resulting from any cause beyond its control. This warranty does not extend to crop loss, losses caused by planting or harvest delays or any expense or loss of labor, supplies, rental machinery, or for any other reason.

**No other warranty of any kind whatsoever expressed or implied, is made with respect to this sale; and all implied warranties of merchantability and fitness for a particular purpose which exceed the obligations set forth in this written warranty are hereby disclaimed and excluded from this sale.**

This warranty is not valid unless registered by a certified Great Plains dealer.

Effective July 15, 2020

©Great Plains Manufacturing Inc., 2004-GPSV

## [Table of Contents](#)

# Index

<b>A</b>			
AccuShot fertilizer system .....	58		
air box .....	30, 83		
clean-out .....	63		
residue .....	63		
air pressure .....	81, 82		
air system			
bulk hopper .....	30		
clean-out .....	63		
row hoppers .....	33		
auxiliary hydraulics .....	17		
<b>B</b>			
back-flow .....	75		
baffles .....	31, 37, 78, 80		
bolt torque values .....	118		
bridging .....	75, 77		
brushes			
drop .....	31, 33, 82		
holder .....	67		
knockout .....	68		
strip .....	31, 33, 66		
tufted .....	31, 33, 80		
bulk hopper .....	108		
bulk hopper level sensor .....	17		
bulk seed tank			
loading .....	39		
scale .....	88		
bushes			
strip .....	82		
<b>C</b>			
case drain hose .....	14, 32, 34		
chain lubrication .....	68		
chain slack .....	68		
check valve .....	35		
check valve installation .....	129		
chemicals .....	3		
contact wheel .....	44, 118		
down pressure spring .....	45		
travel distance .....	44		
contact wheel pressure .....	118		
coulter blades .....	91		
cylinder lock .....	19		
<b>D</b>			
dealer content .....	119		
center lift hydraulics .....	119		
check valve .....	122		
check valve removal .....	122		
close-out .....	125		
cylinder locks			
storage position .....	121		
IntelliAg .....	120, 122		
not for customer use .....	119		
rephasing hydraulics .....	125		
shipping chain			
center lift only .....	119		
wing gauge wheels .....	119		
shipping check valve kit			
removal .....	122		
switch box .....	121, 124		
tools required .....	119		
trailer shipping .....	122		
unloading planter .....	119		
wing gauge wheels .....	119		
diagrams			
dual fans .....	108		
fold .....	107		
lift .....	105, 106		
markers .....	110		
single fan .....	109		
weight transfer .....	111		
Dickey-john .....	87		
disk scraper .....	91		
disk scrapers .....	69		
disk separator .....	47, 69		
disks .....	49, 83		
disk-to-wheel angle .....	49		
disk-to-wheel clearance .....	49		
doubles .....	36		
drop brush .....	31, 33, 66, 67, 82		
dual fans .....	108		
<b>E</b>			
earmuff .....	2		
earplugs .....	2		
electrical connections .....	13		
employer responsibility .....	1		
Ezee Glide Plus .....	80, 83		
<b>F</b>			
fan adjustment .....	35		
fan hydraulics			
bulk hoppers .....	32		
row hoppers .....	34		
fan pressure hose .....	33, 34		
fan speed .....	81, 83		
fertilizer .....	55, 70, 85		
capacity .....	94–97		
dribblers .....	89		
ground drive .....	58, 89, 90		
hydraulic drive .....	57, 90		
pump .....	85, 86		
rate .....	57		
relief valve .....	56		
strainer .....	56, 70, 85		
system .....	89		
tank .....	89		
folding .....	25		
fuse boxes .....	115–117		
IntelliAg .....	115, 116		
IRC .....	116		
switch box .....	115		
Topcon .....	117		
<b>G</b>			
grease fittings .....	71		
<b>H</b>			
height switch .....	46		
hitching .....	12		
hopper .....	33		
loading .....	39		
hydraulic			
hose colors .....	12		
hose connections .....	12		
oil .....	15		
hydraulic diagrams .....	105–111		
dual fans .....	108		
lift .....	105, 106		
markers .....	110		
single fan .....	109		
weight transfer .....	111		
hydraulic drive .....	43, 45		
hydraulic fluid .....	3		
hydraulic oil reservoir .....	15		
hydraulic system maintenance .....	61		
hydraulic system repair .....	61		
hydraulic system repairs .....	136		
hydraulics			
fold .....	14		
rear auxiliary .....	17, 87		
hydraulics diagrams			
fold .....	107		
<b>I</b>			
initial use instructions .....	12		
IntelliAg .....	115		
IRC .....	45		
<b>K</b>			
Keeton® seed firmer .....	47, 54, 88		
knockout brush .....	67		
<b>L</b>			
leveling .....	15		
liquid fertilizer			
pump .....	17		
locks .....	19		
cylinder locks .....	19		
tongue hook latch .....	20		
wing hooks .....	19		
lubrication .....	71		
<b>M</b>			
maintenance safety .....	4		
markers .....	55, 79, 84, 88		
auxiliary hydraulics .....	28		
selector valve .....	28		
chain length .....	17		
control lift sequence .....	29		
disk .....	17, 84		
disk hub .....	62		
extension .....	16		
table lengths .....	16		

operation .....	28	gate .....	31, 33, 41, 81, 82	<b>U</b>	
shear bolt .....	61	seed lubricant .....	40, 80, 82, 89	UMC-RC .....	52
warning .....	28	seed meter .....	46	UMRC .....	52
motor return hose .....	33, 34	adjustment .....	40	unit mount coultter .....	46, 53
<b>N</b>		air flow .....	31	<b>V</b>	
not for customer use .....	119, 126	brushes .....	65	VeriFlow nozzle .....	90
<b>O</b>		clean-out .....	64	VisaGage II .....	90
opener disk .....	46, 49	clean-out container .....	92	<b>W</b>	
angle .....	49	disk .....	40, 68, 92	waste disposal .....	3
stagger .....	49	drive chain .....	62, 69	weight transfer .....	88, 111
orifice plate .....	85, 86, 89	operation .....	42	wheel bearings .....	71
<b>P</b>		rain cover .....	40	wing .....	27
parking .....	58	seed pool .....	31, 33, 74	wing hooks .....	27, 127, 129
planter		slope .....	42		
electrical connections .....	13	troubleshooting .....	74		
ground speed .....	15	seed population .....	78		
hydraulic connections .....	12	seed rate .....	80		
leveling .....	15	seed tube .....	31, 33, 46, 79, 80, 81		
planter leveling .....	15	brush .....	92		
planting		clean-out .....	65		
depth .....	49	sensor .....	31, 33, 78		
rate .....	43	serial number .....	1		
press wheel .....	46, 84, 91	shipping chain .....	139		
adjustment .....	51	center lift only .....	139		
centering .....	51	do not unfold .....	139		
down pressure .....	51	removal .....	139		
stagger .....	51	shutdown .....	4		
pressure gauge .....	32, 34	shut-off gate .....	63, 64		
pressure sensor chamber .....	32, 34	side depth wheel .....	46, 49, 69		
pressure sensor port .....	32, 34	adjustment .....	50		
pressurization air inlet .....	46	scraper .....	51, 92		
pressurization tubes .....	31, 33	skips .....	36		
<b>R</b>		specifications .....	94–118		
range sprockets .....	43, 44	speed calibration .....	15, 79, 82		
rear auxiliary hydraulics .....	39	speed sensor .....	15, 78, 81, 82		
rear hitch .....	88	storage .....	4, 72		
relief valve .....	85	strip brush .....	31, 33, 66, 82		
rephase hydraulic system .....	23	Swath Command™ .....	55, 87		
rephasing hydraulics .....	14	<b>T</b>			
reverse fan .....	35	T-handle .....	46, 49		
row cleaner .....	46, 52, 91	tires .....	118		
row hopper .....	109	pressure .....	118		
row unit .....	46	warranty .....	118		
down pressure .....	47	wheel bolt torque .....	118		
<b>S</b>		tongue hook latch .....	20		
safety .....	2	Topcon .....	117		
safety decals .....	5–10	fuse box diagram .....	117		
scraper .....	46, 69, 91, 92	XD .....	117		
section control .....	29	XD-Plus .....	117		
seed		Trailer Transport .....	59		
capacity .....	94–97	training .....	1		
seed cells .....	31, 33	transmission sprockets .....	43, 44		
seed delivery fan .....	30	transport .....	57		
seed disk .....	40, 68, 92	dimensions .....	98–104		
seed firmmer .....	47, 54, 80	transport speed .....	4		
seed flap .....	47, 70	tufted brush .....	31, 33, 66, 80		
seed inlet .....	31, 46	two-point hitch .....	13		

## [Table of Contents](#)



**“Harvest Starts Here.”**



**MADE IN USA**  
WITH U.S. & GLOBAL COMPONENTS

**Great Plains Mfg.**  
1525 E. North St.  
P.O. Box 5060  
Salina, KS 67402