

Operator's Manual

PT1230

Pull-Type Folding Planter

Model

Serial No.

PT1230

AA1061 and Earlier

Great Plains

Manufacturing, Inc.

P.O. Box 5060 • Salina, Kansas 67402-5060



Read the operator's manual entirely. When you see this symbol, the subsequent instructions and warnings are serious - follow without exception. Your life and the lives of others depend on it!

Great Plains

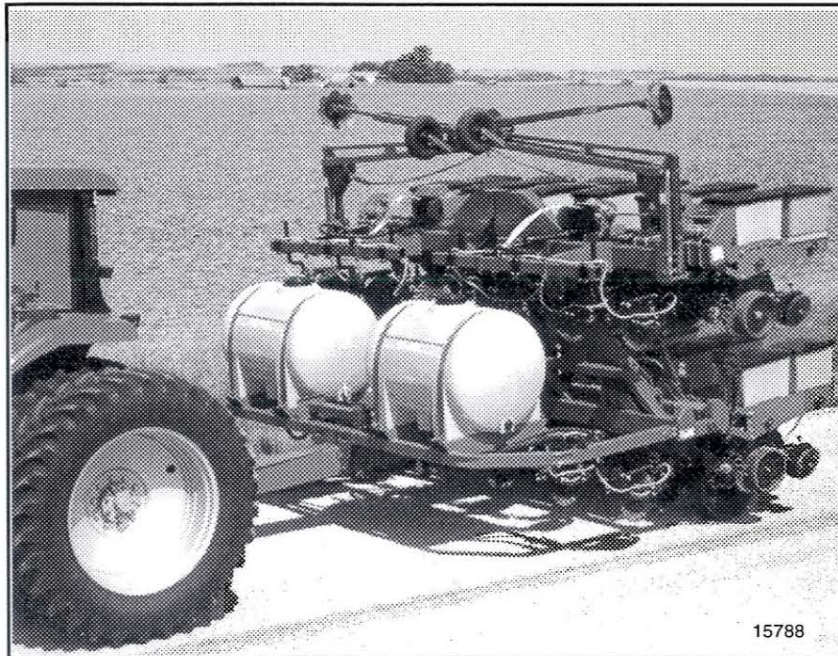

Cover illustration may show optional equipment not supplied with standard unit.

Table of Contents

Important Safety Information	1	Tire Scraper (Optional)	32
Introduction	9	Seed Lok® (Optional)	32
Description of Unit	9	Section 5 Planting Rate Adjustments	33
Intended Usage	9	Planting Rates	33
Using This Manual	9	Drive Wheel Slippage	34
Owner Assistance	9	Adjusting Granular Chemical Rates	34
Section 1 Planter Preparation and Setup	11	Liquid Fertilizer Attachment	35
Initial Preparation of the Planter	11	Planting Rates for Corn Meters	36
Tractor Requirements	11	Planting Rates for Brush Meters	37
Safety Lights	11	Liquid Fertilizer Rates	39
Tractor Hydraulic Hookup	11	Insecticide/Herbicide Application Rates	40
Tractor Drawbar Hookup	11	Section 6 Troubleshooting	46
Tire Pressure	12	Section 7 Maintenance and Lubrication	50
Section 2 Planter Operation	13	Installing Transport Locks	50
Folding	13	Fasteners	50
Unfolding	14	Replacing Drill Shaft Cotter Pins and	
Transporting	17	Countershaft Shear Pins	51
Leveling the Planter	17	Finger Pickup Meter	51
Wing/Mainframe Lowering Adjustment	18	Brush-Type Seed Meter	53
Parking	18	Scraper Weldment	53
Rephasing the Hydraulic System	18	Disk	53
Marker Hydraulics	18	Gauge Wheels	54
Marker Transporting	20	Outside Scrapers	54
Liquid Fertilizer Attachment	20	Chain Tension	55
Section 3 Row Unit Operation	22	Cleaning Insecticide and/or Herbicide Hoppers	56
Finger Pickup Meter	22	Cleaning Liquid Fertilizer Tanks	56
Brush Meter	22	Squeeze Pumps	56
Meter Clutches	23	Marker Breakaway Protection	56
Point Row Clutch	23	Storage	56
Seed Hopper	24	Lubrication	58
Chemical Hopper	24	Section 8 Options	67
Recalibrating Insecticide/Herbicide Meter	26	16" Wheel Cover	67
Section 4 Adjustments	27	Spring Package	67
Marker Disk Adjustments	27	Seed Lok®	67
Contact Drive Wheel Spring	28	Unit Mount Coultter Option	68
Seed and Chemical Meter Drive Adjustments	28	Vantage I Option	68
Depth Adjustment	29	Vantage II Option	68
Down Force Row	29	Terra Tine Option	69
Row Unit Mounted Coultter Adjustment	30	DICKY-john® Monitor Option	69
1 x 12 Closing Wheel Adjustments	30	Insecticide & Herbicide Option	70
Closing Disk Adjustments	31	Section 9 Specifications and Capacities	71
Ridge Planting	31	Section 10 Appendix	73
Liquid Fertilizer Adjustments	32	Tire Inflation Chart	73
		Torque Values Chart for Common Bolt Sizes	73

© Copyright 1996 All rights Reserved

Great Plains Manufacturing, Inc. provides this publication "as is" without warranty of any kind, either expressed or implied. While every precaution has been taken in the preparation of this manual, Great Plains Manufacturing, Inc. assumes no responsibility for errors or omissions. Neither is any liability assumed for damages resulting from the use of the information contained herein. Great Plains Manufacturing, Inc. reserves the right to revise and improve its products as it sees fit. This publication describes the state of this product at the time of its publication, and may not reflect the product in the future.

Great Plains Manufacturing, Incorporated Trademarks

The following are trademarks of Great Plains Mfg., Inc.: Application Systems, Ausherman, Land Pride, Great Plains

All other brands and product names are trademarks or registered trademarks of their respective holders.

Printed in the United States of America.

Important Safety Information

Be Aware of Signal Words

The word that designates a degree or level of hazard seriousness. The signal words are:

⚠ DANGER!

Indicates an imminently hazardous situation which, if not avoided, will result in death or serious injury. This signal word is limited to the most extreme situations, typically for machine components that, for functional purposes, cannot be guarded.

⚠ WARNING!

Indicates a potentially hazardous situation which, if not avoided, could result in death or serious injury, and includes hazards that are exposed when guards are removed. It may also be used to alert against unsafe practices.

⚠ CAUTION!

Indicates a potentially hazardous situation which, if not avoided, may result in minor or moderate injury. It may also be used to alert against unsafe practices.



Keep Riders Off Machinery

- ▲ Riders obstruct the operator's view they could be struck by foreign objects or thrown from the machine.
- ▲ Never allow children to operate equipment.

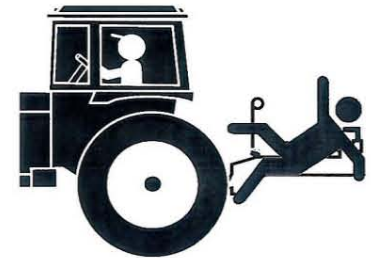

For Your Protection

- ▲ Thoroughly read and understand the "Safety Label" section, read all instructions noted on them.

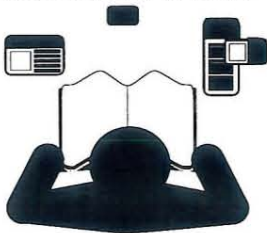

Handle Chemicals Properly

- ▲ Protective clothing should be worn.
- ▲ Handle all chemicals with care.
- ▲ Follow instructions on container label.
- ▲ Agricultural chemicals can be dangerous. Improper use can seriously injure persons, animals, plants, soil, and property.
- ▲ Inhaling smoke from any type of chemical fire is a serious health hazard.
- ▲ Store or dispose of unused chemicals as specified by the chemical manufacturer.
- ▲ Chemical hopper may tip backwards when unlatched.



Shutdown and Storage

- ▲ Lower machine to ground, put tractor in park, turn off engine, and remove the key.
- ▲ Detach and store implements in a area where children normally do not play. Secure implement by using blocks and supports.

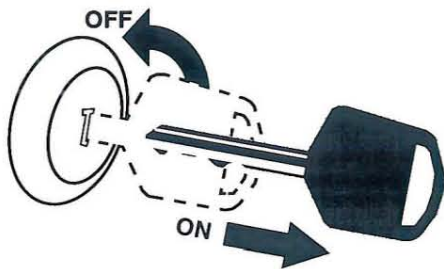

Important Safety Information

Use Safety Lights and Devices

- ▲ Slow moving tractors, self-propelled equipment, and towed implements can create a hazard when driven on public roads. They are difficult to see, especially at night.
- ▲ Flashing warning lights and turn signals are recommended whenever driving on public roads. Use lights and devices provided with implement.

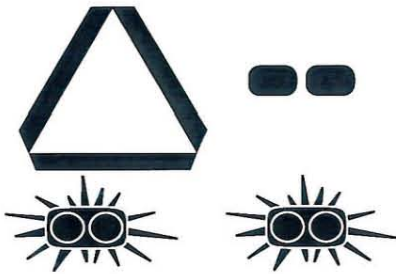

Transport Machinery Safely

- ▲ Comply with state and local laws.
- ▲ Maximum transport speed for implement is 20 mph. DO NOT EXCEED. Never travel at a speed which does not allow adequate control of steering and stopping. Some rough terrains require a slower speed.
- ▲ Folded planter will have a high center of gravity. Use caution when traveling on an uneven surface.
- ▲ Transport with transport lock in place.



- ▲ Sudden breaking can cause a towed load to swerve and upset. Reduce speed if towed load is not equipped with brakes.
- ▲ Use the following maximum speed - tow load weight ratios as a guideline:
 - 20 mph** when weight is less than or equal to the weight of tractor.
 - 10 mph** when weight is double the weight of tractor.

IMPORTANT: Do not tow a load that is more than double the weight of tractor.

Use A Safety Chain

- ▲ A safety chain will help control drawn machinery should it separate from the tractor drawbar.
- ▲ Use a chain with the strength rating equal to or greater than the gross weight of the towed machinery.
- ▲ Attach the chain to the tractor drawbar support or other specified anchor location. Allow only enough slack in the chain to permit turning.
- ▲ Do not use safety chain for towing.

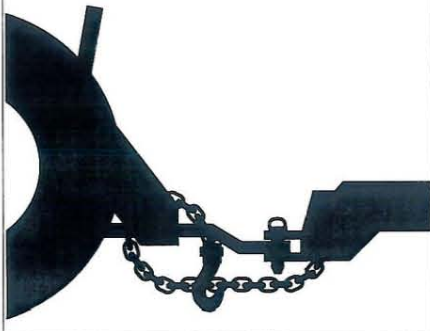

Practice Safe Maintenance

- ▲ Understand procedure before doing work. Use proper tools and equipment, refer to Operator's Manual for additional information.
- ▲ Work in a clean dry area.
- ▲ Lower the implement to the ground, put tractor in park, turn off engine, and remove key before performing maintenance.
- ▲ Allow implement to cool completely.
- ▲ Install all transport locks on raised planter before working around or underneath.
- ▲ Do not grease or oil implement while it is in operation.

- ▲ Disk edges and coulter blades are sharp. Be careful when working in this area.
- ▲ Disconnect battery ground cable (-) before servicing or adjusting electrical systems or before welding on implement.
- ▲ Inspect all parts. Make sure parts are in good condition & installed properly.
- ▲ Remove buildup of grease, oil or debris.
- ▲ Remove all tools and unused parts from implement before operation.



Important Safety Information

Prepare for Emergencies

- ▲ Be prepared if a fire starts.
- ▲ Keep a first aid kit and fire extinguisher handy.
- ▲ Keep emergency numbers for doctor, ambulance, hospital and fire department near phone.



Wear Protective Equipment

- ▲ Protective clothing and equipment should be worn.
- ▲ Wear clothing and equipment appropriate for the job. Avoid loose fitting clothing.
- ▲ Prolonged exposure to loud noise can cause hearing impairment or hearing loss. Wear suitable hearing protection such as earmuffs or earplugs.
- ▲ Operating equipment safely requires the full attention of the operator. Avoid wearing radio headphones while operating machinery.



Avoid High Pressure Fluids Hazard

- ▲ Escaping fluid under pressure can penetrate the skin causing serious injury.
- ▲ Avoid the hazard by relieving pressure before disconnecting hydraulic lines.
- ▲ Use a piece of paper or cardboard, NOT BODY PARTS, to check for suspected leaks.
- ▲ Wear protective gloves and safety glasses or goggles when working with hydraulic systems.
- ▲ If an accident occurs, see a doctor immediately. Any fluid injected into the skin must be surgically removed within a few hours or gangrene may result.



Safety at All Times

Thoroughly read and understand the instructions given in this manual before operation. Refer to the "Safety Label" section, read all instructions noted on them.

- ▲ Operator should be familiar with all functions of the unit.
- ▲ Operate implement from the driver's seat only.
- ▲ Do not leave tractor or implement unattended with engine running.
- ▲ Dismounting from a moving tractor could cause serious injury or death.
- ▲ Do not stand between the tractor and implement during hitching.
- ▲ Keep all guards and shields in place.
- ▲ Keep hands, feet, and clothing away from power-driven parts.
- ▲ Wear snug fitting clothing to avoid entanglement with moving parts.
- ▲ Watch out for wires, trees, etc., when folding and raising implement.

- ▲ Make sure all persons are clear of working area when folding or unfolding planter or markers.
- ▲ Turning tractor too tight may cause implement to ride up on wheels. This could result in injury or equipment damage.
- ▲ Use caution when lifting filled hoppers which can weigh up to 120 lbs.
- ▲ Adjust spring pressure with row unit in transport position only.
- ▲ Gap between depth gauge wheel and disk blade may pinch fingers. Be careful when checking.
- ▲ Filled chemical hoppers may tip backward when unlatched.



Tire Safety

- ▲ Tire changing can be dangerous and should be performed by trained personnel using the correct tools and equipment.
- ▲ When inflating tires, use a clip-on chuck and extension hose long enough to allow you to stand to one side and NOT in front of or over the tire assembly. Use a safety cage if available.
- ▲ When removing and installing wheels, use wheel handling equipment adequate for the weight involved.



Important Safety Information

Safety Labels

Your implement comes equipped with all safety labels in place. They were designed to help you safely operate your implement.

1. Read and follow label directions.
2. Keep all safety labels clean and legible.
3. Replace all damaged or missing labels.
4. Some new equipment installed during repair require safety labels to be affixed to the replaced component as specified by the manufacturer. When ordering new components make

sure the correct safety labels are included in the request. To order new labels go to your Great Plains dealer.

5. Refer to this section for proper label placement.

To install new labels:

- a. Clean the area the label is to be placed.
- b. Peel backing from label. Press firmly on surface being careful not to cause air bubbles under label.

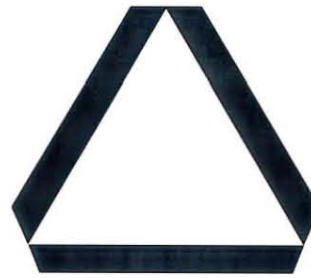
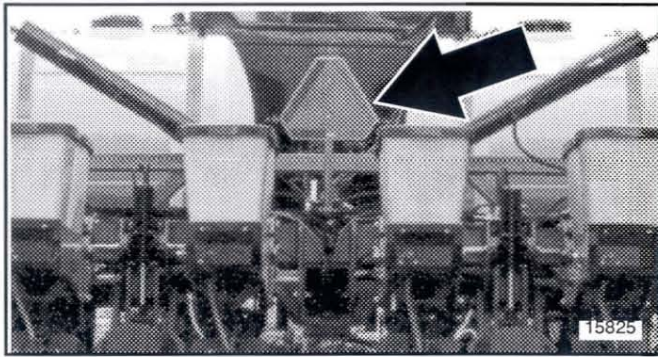

818-003C

Slow Moving Vehicle Label

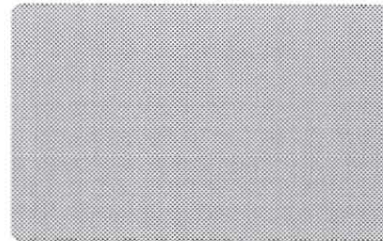
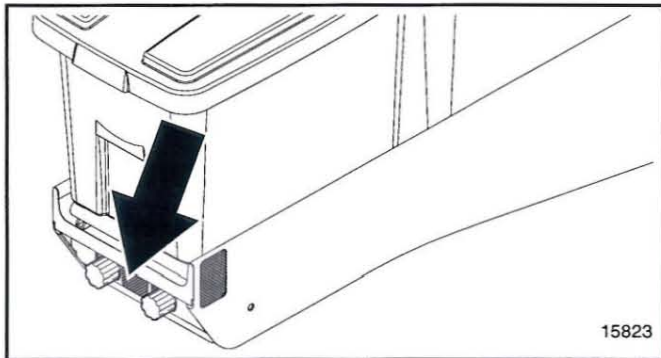

818-230C

Red Reflector

One on each outside mainframe row unit

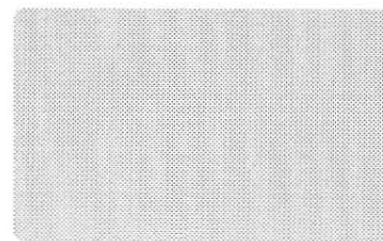
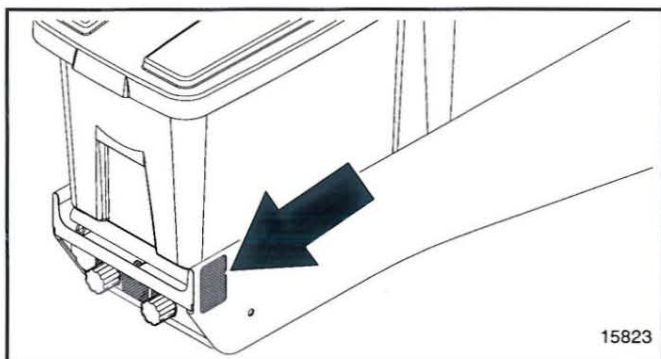

818-229C

Amber Reflector

One on each outside mainframe row unit

Important Safety Information

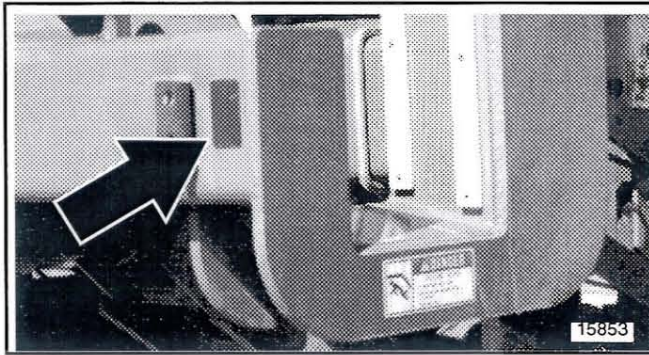

818-229C
Amber Reflector

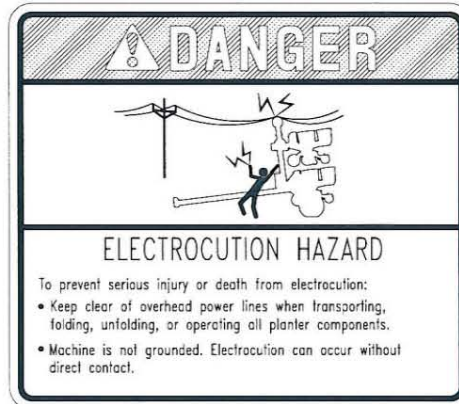
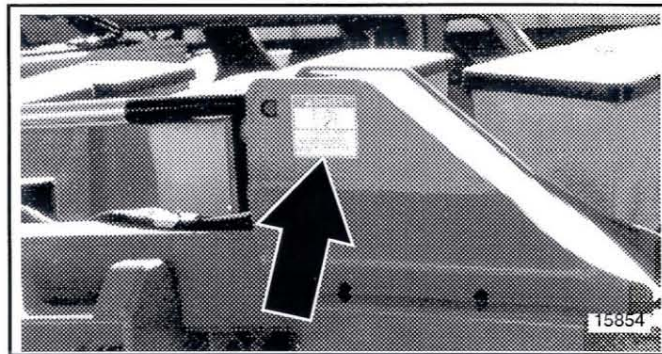
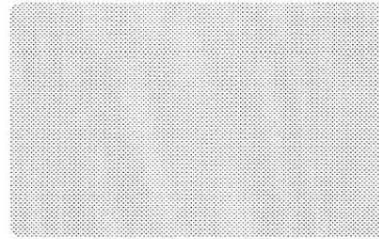

818-765C
Electrocution

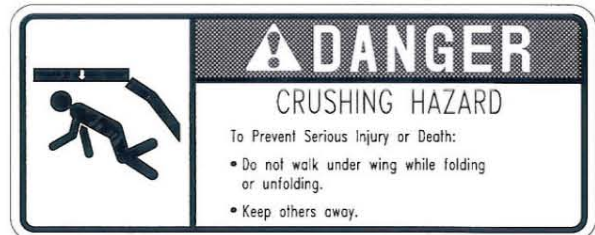
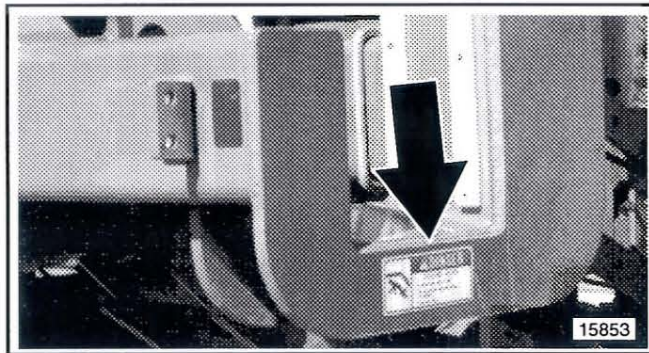

818-766C
Crushing

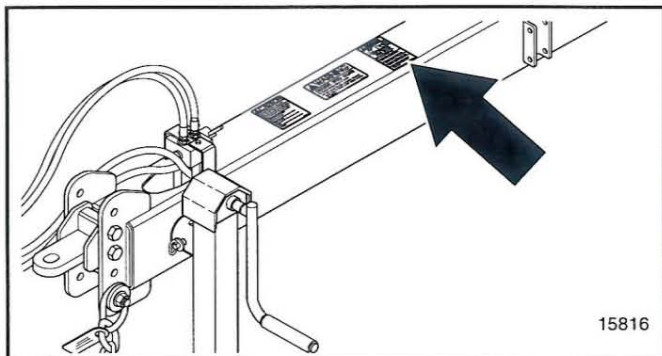

818-339C
High Pressure Fluid

Important Safety Information

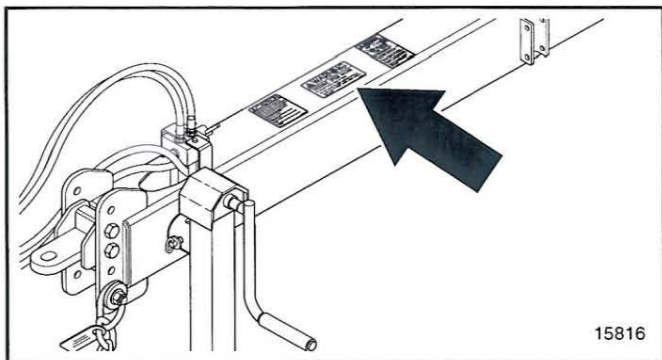

! WARNING

EXCESSIVE SPEED HAZARD

To Prevent Serious Injury or Death:

- Do Not exceed 20 mph maximum transport speed. Loss of vehicle control and/or machine can result.

818-188C No. 1

818-188C
Excessive Speed

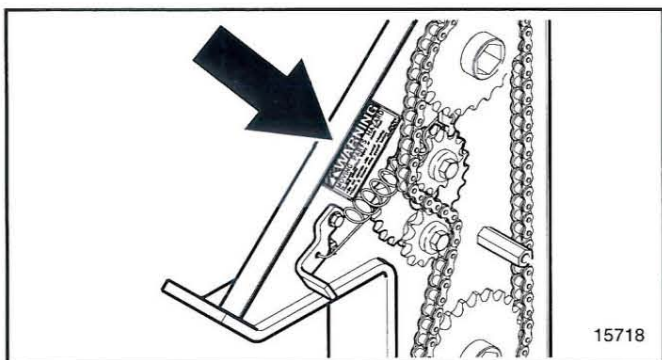

! WARNING

MOVING PARTS HAZARD

To prevent serious injury or death from moving parts:

- Do not operate with guard missing
- Close & secure drive guard before starting

818-205C Rev. B

818-205C
Moving Parts

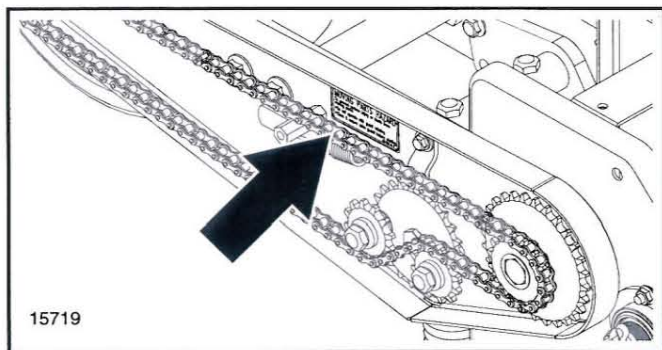

! WARNING

MOVING PARTS HAZARD

To prevent serious injury or death from moving parts:

- Do not operate with guard missing
- Close & secure drive guard before starting

818-205C Rev. B

818-205C
Moving Parts



! WARNING

MOVING PARTS HAZARD

To prevent serious injury or death from moving parts:

- Do not operate with guard missing
- Close & secure drive guard before starting

818-205C Rev. B

818-205C
Moving Parts

Important Safety Information

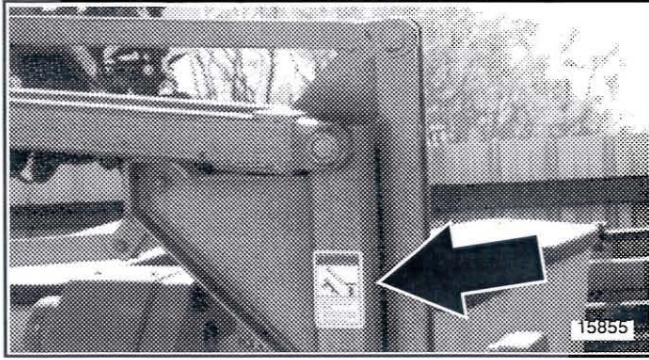

818-682C
Marker Crushing

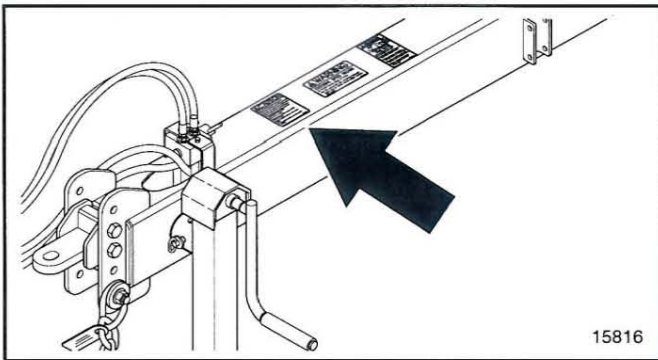

818-587C
General Safety

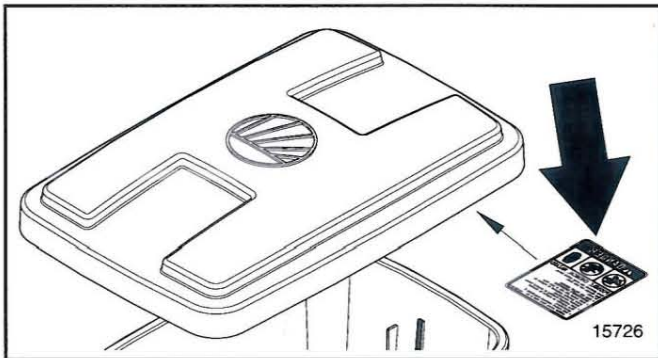

818-323C
Chemical

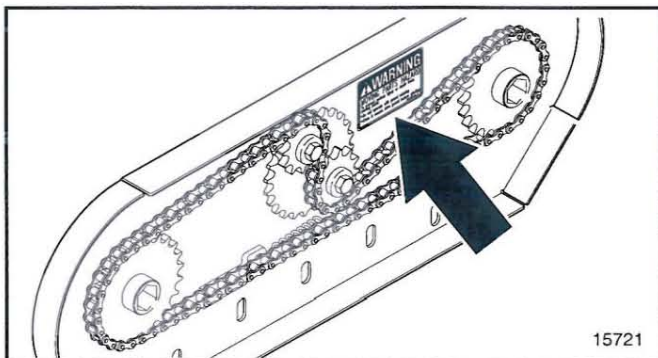

818-205C
Moving Parts
Liquid Fertilizer Drive

Important Safety Information

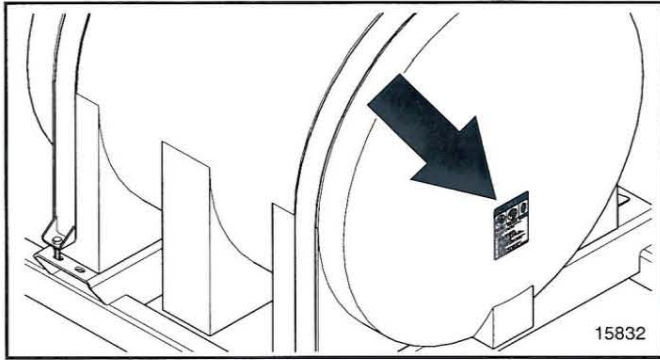

818-323C
Chemical

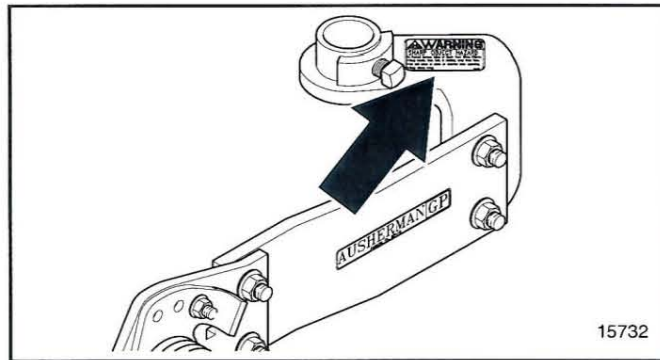

818-525C
Sharp Object
Terra Tine Option

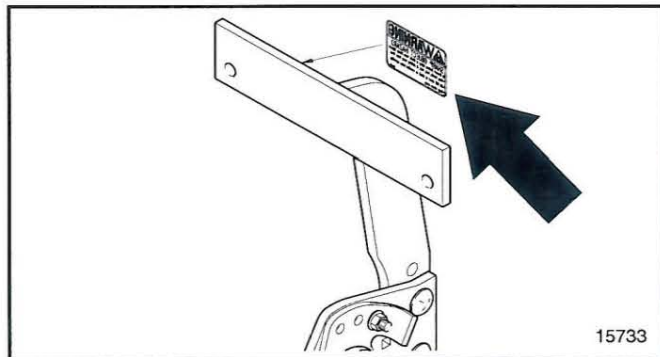

818-525C
Sharp Object
Terra Tine Option

Introduction

Great Plains welcomes you to the growing family of new product owners.

This implement has been designed with care and built by skilled workers using quality materials. Proper assembly, maintenance, and safe operating practices will help you get years of satisfactory use from the machine.

Description of Unit

The 12-row, 30 inch row spacing pull-type planter has six rigid center rows and 3 rows on each end which float independently in field operation. The outer 3 rows on each end lift and fold above the center rows for transporting. Field turns can be completed in a relatively small radius due to the lift wheels and short tongue.

The PL1230, liquid fertilizer attachment, allows application of liquid fertilizer and coulter mounting. This complete system allows you to band liquid fertilizer on 12 rows with two 230 gallon liquid tanks and an optional squeeze pump.

Features include:

- Constant tongue weight in both field and transport positions.
- A transmission located on each end of the toolbar, each engaging six rows.
- 2 bushel, narrow profile seed hoppers.
- Electric clutch to allow shut off of right or left side row units.
- Safety lights which couple with the tractor's lighting system.

Intended Usage

This machine is intended for planting row crops in conventional as well as no-till conditions.

Using This Manual

This Operator's Section is designed to help familiarize you with safety, assembly, operation, adjustments, troubleshooting, and maintenance. Read this manual and follow the recommendations to help ensure safe and efficient operation.

The warranty sheet should be filled out by the owner and dealer at the time of purchase. After completion give the dealer the white copy and send the pink copy to Great Plains. Keep your copy in the manual for use when corresponding with the dealer.

To order a new Operator or Parts Manual contact your authorized dealer or write to the address listed below in the *Owner Assistance* paragraph. Include the model and serial numbers of your unit.

The information contained within this manual was current at the time of printing. Some parts may change slightly to assure you of the best performance.

Terminology:

"Right " or "Left" as used in this manual is determined by facing the direction the machine will travel while in use unless otherwise stated.

Definitions:

NOTE: A special point of information related to it's preceding topic. The author's intention is that you read and note this information before continuing.

IMPORTANT: A special point of information that the author feels you must be aware of before continuing with the instructions that follow.

Owner Assistance

If customer service or repair parts are required contact your local Great Plains dealer. He has trained personnel, repair parts, and the equipment needed to service your implement.

These parts have been specially designed and should only be replaced with genuine Great Plains parts.

Serial Number Plate

Refer to the Figure 1 for the location of your serial number plate.

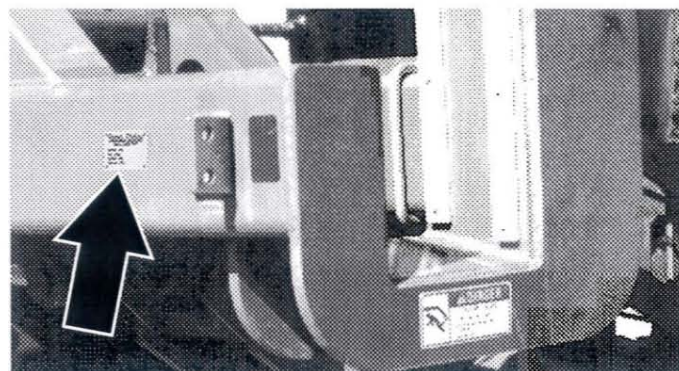

Serial Number Plate Location
Figure 1

15856

For prompt service always use the serial number and model number when ordering parts from your Great Plains dealer. Be sure to include your serial and model numbers in correspondence also.

Your dealer wants you to be satisfied with your new machine. If for any reason you do not understand any part of this manual or are not satisfied with the service received, the following actions are suggested:

1. Discuss the matter with your dealership service manager make sure he is aware of any problems you may

Introduction

have and that he has had the opportunity to assist you.

2. If you are still not satisfied, seek out the owner or general manager of the dealership, explain the problem and request assistance.
3. For further assistance write to:

Product Support

Great Plains Mfg. Inc., Service Department

P.O. Box 245

Assaria, Ks. 67416

Section 1 Planter Preparation and Setup

Initial Preparation of the Planter

- Lubricate the planter as indicated in the *Lubrication* portion of “Section 7 Maintenance and Lubrication” on page 50.
- Check the chains for proper tension and alignment as shown in “Section 7 Maintenance and Lubrication” on page 50.
- Perform all beginning of season and daily planter service as discussed in “Section 7 Maintenance and Lubrication” on page 50.
- Check over the planter and replace worn or damaged parts before going to the field.
- All nuts, bolts and screws should be checked. Refer to the *Torque Values Chart for Common Bolt Sizes* in “Section 10 Appendix” on page 73.

Tractor Requirements

The minimum required draw bar horsepower for field work with the 12-row planter is 160 HP. Consult your dealer for information on horsepower requirements and tractor compatibility. Requirements will vary with planter options, tillage and terrain. Two dual remote hydraulic outlets (SCV) are required.

Safety Lights

The light package that your planter is equipped with, requires that your tractor have the correct electrical connections. Your tractor should be wired for a standard 7-pin electrical connector which works with the tractor's flashers and turn signals. All that should be necessary to hook up the lights is to plug them into the tractor's 7-pin connector.

If your tractor is not equipped with a 7-pin connector, please contact your local dealer for installation to your tractor manufacturers specifications.

Tractor Hydraulic Hookup

Plug in implement hydraulic remote couplers by observing hydraulic cylinder raise and lower symbols on hose clamp, see Figure 1-1. Plug extend symbol on planter in extend symbol on tractor.

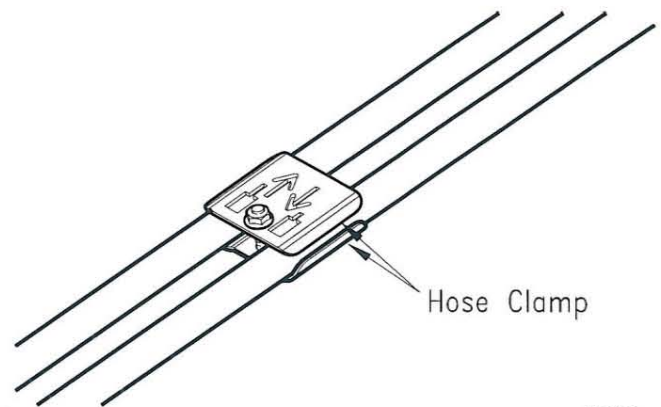

15831

Hose Clamp
Figure 1-1

If tractor couplers are not marked, connect couplers so moving the tractor valve control lever forward lowers planter, and moving tractor back raises planter.

Tractor Drawbar Hookup

Proper tongue adjustment improves seed placement by allowing the row units to operate parallel to the ground. (See also *Leveling the Planter* on page 17.)

The mounting holes in the hitch have been offset so the hitch can be turned over and bolted on in four positions, giving eight hitching positions. Use the screw jack to raise the front of the planter tongue. Adjust the planter hitch to match your tractor drawbar. The planter hitch can accommodate tractor drawbars ranging from 12 1/8" to 22 5/8" high. See Figure 1-2.

NOTE: When hitching the planter to a different tractor, check for a difference in drawbar heights. If the heights are different, the hitch height must be readjusted accordingly.

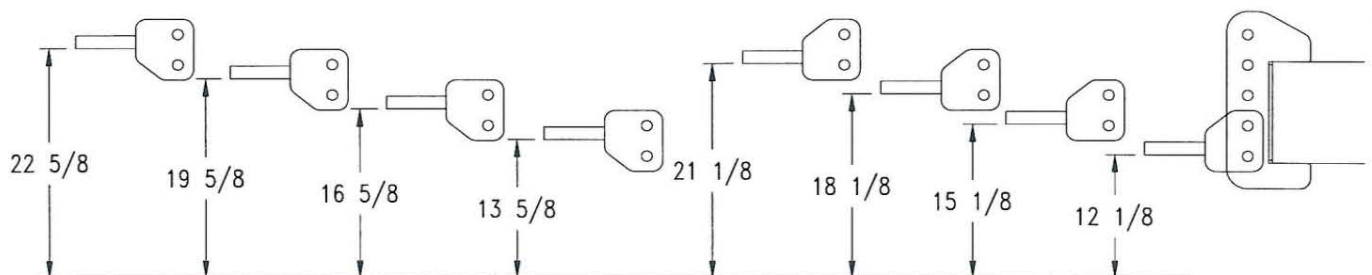

Hitch Positions
Figure 1-2

15819

Section 1 Planter Preparation and Setup

Use the jack to raise and lower the front of the planter when hitching to the tractor, and store it in the storage tube on the top of the tongue as shown in Figure 1-3.

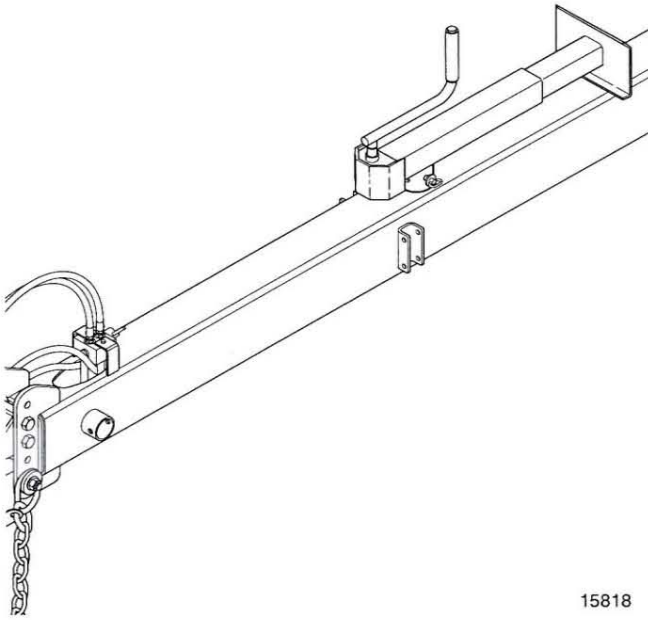

15818

Jack in Storage Position
Figure 1-3

Your planter is equipped with a hitch safety chain. The safety chain should be securely attached to the planter hitch and the tractor whenever towing or planting.

Tire Pressure

Tire pressure should be checked regularly and maintained as follows. Correct tire inflation pressures improve tire life and seed population. Do not inflate tires above recommended pressure.

Wing Ground Drive 9.5L X 15-12 ply	60 psi
Transport 9.5L X 15-12 ply	60 psi
Contact Drive 13-6.50 X 6	40 psi



DANGER!

Tire changing can be dangerous and should be performed by trained personnel using the correct tools and equipment. When removing and installing wheels, use wheel handling equipment adequate for the weight involved.

Section 2 Planter Operation

Folding

DANGER!

Keep others away during folding operations. Do not walk under wings when folding planter. See Figure 2-9 on page 16 before attempting to unfold planter.

Folding is best achieved on level ground with the tractor transmission in neutral. Be aware of the clearance required to fold the planter.

DANGER!

Keep clear of overhead power lines when folding planter and/or markers.

NOTE: Before folding or unfolding it is recommended to rephase the hydraulic system by holding the tractor remote lever in the opposite position. For example, if folding hold the lever to unfold for the time needed to have both master and slave cylinder in phase. The hydraulic system will rephase in either planting or raised position.

1. Lift planter.
2. Switch hydraulic selector valve from "Field" to "Road". See Figure 2-1.

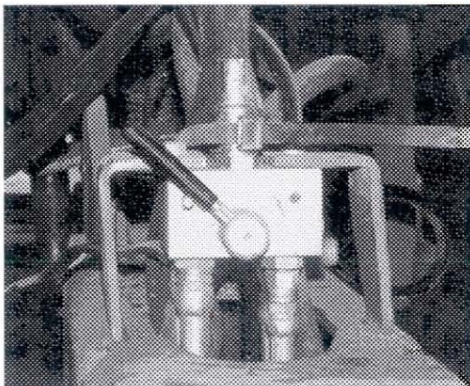

15857

Hydraulic Selector Valve in "Road" Position
Figure 2-1

3. Lock the four transport locks in place by pulling up on the transport lock handle. Snap handle into keeper for storage. See Figure 2-2.

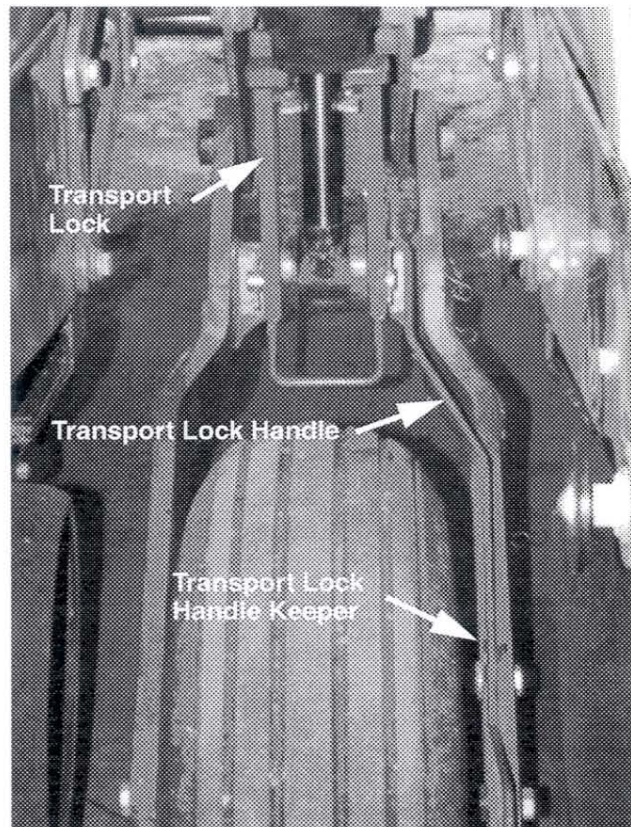

15858

Locking Transport Locks
Figure 2-2

4. Pull out wing lock pins. See Figure 2-3.

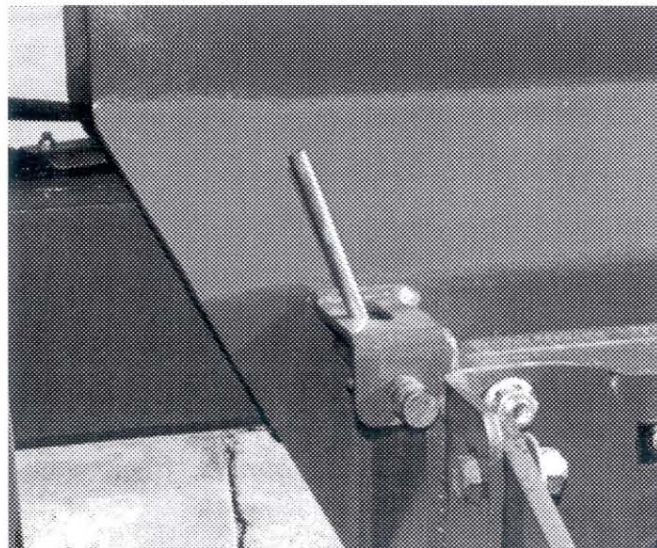

15859

Arm Wing Lock Pin in Unlocked Position
Figure 2-3

Section 2 Planter Operation

Planters with Liquid Fertilizer Attachment

For planters with the Liquid Fertilizer Attachment be sure to disconnect the coupler shown in Figure 2-4 before folding.

Set stops on coulters to prevent damage to tanks.

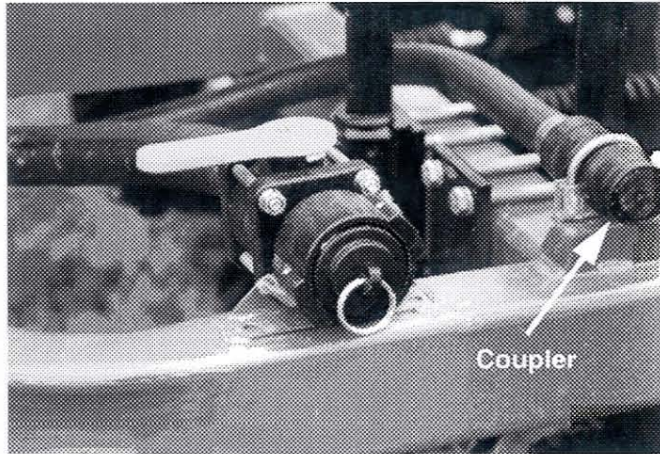

Liquid Fertilizer coupler
Figure 2-4

15880

5. Start folding. The drive shaft will automatically disconnect as planter is folding.
6. After wings are off the ground, lower planter. This will retract the wing gauge wheels. The transport locks will keep planter from lowering to the ground.

NOTE: It is important that the wing gauge wheels are retracted before continuing to fold the planter. Failure to retract wheels will lead to hopper damage.

7. Continue folding until wings are positioned above the planter main frame.
8. Completely retract hydraulic cylinders to rephase the system.

Unfolding

DANGER!

Keep others away during unfolding operations. Do not walk under wings when unfolding planter. See Figure 2-9 on page 16 before attempting to unfold planter.

Unfolding is best achieved on level ground with the tractor transmission in neutral. Be aware of the clearance required to unfold the planter.

DANGER!

Keep clear of overhead power lines when unfolding planter and/or markers.

IMPORTANT: If unfolding planter with hoppers fully loaded, you will need a tractor with at least 2150 psi hydraulic pressure.

1. Make sure hydraulic selector valve is in the "Road" position. See Figure 2-1 on page 13.

NOTE: If the planter has set in the folded position for awhile, be sure the wing gauge wheels are fully retracted before beginning to unfold planter. If wheels are not retracted hopper damage will occur when unfolding planter. Retract wheels by lowering planter on transport locks.

2. Begin to unfold planter.
3. When wings are over-center, raise planter. This will lower the wing gauge wheels.
4. Continue unfolding planter until hydraulic cylinders are fully extended.
5. When wing gauge wheels contact the ground, pull planter ahead a few feet while continuing to lower. This will level wings.
6. Unlock the four transport locks by pulling down on transport lock handle. Snap handle into keeper for storage. See Figure 2-5.

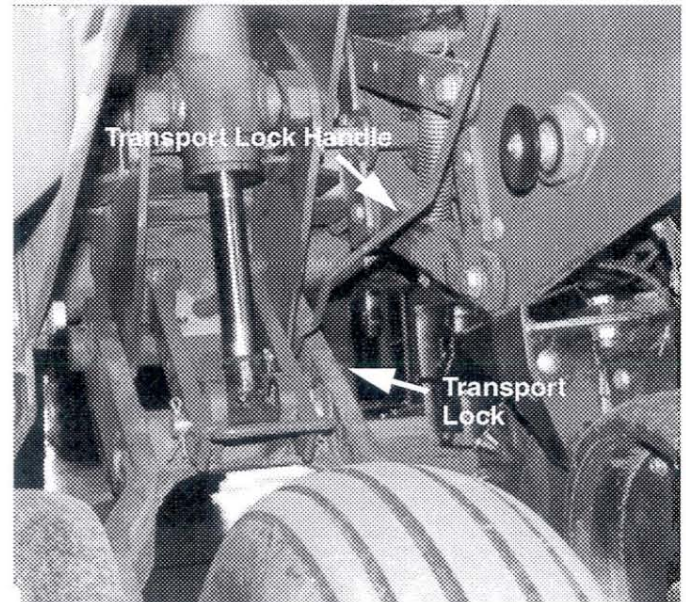

Unlocking Transport Locks
Figure 2-5

15860

7. Position arm wing lock pins as shown, see Figure 2-6. If wings are not level, it may be necessary to pull forward a few feet to lock wing lock pins.

Section 2 Planter Operation

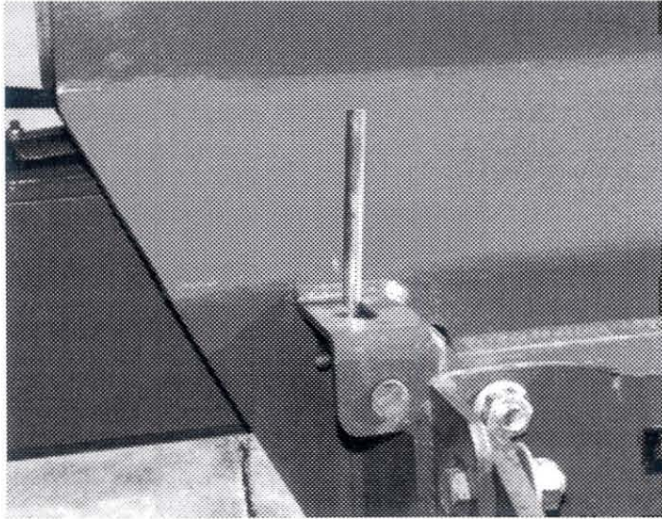

Arm Wing Lock Pin in Locked Position
Figure 2-6

15861

Planters with Liquid Fertilizer Attachment

For planters with the Liquid Fertilizer Attachment, connect the coupler shown in Figure 2-8 after unfolding.

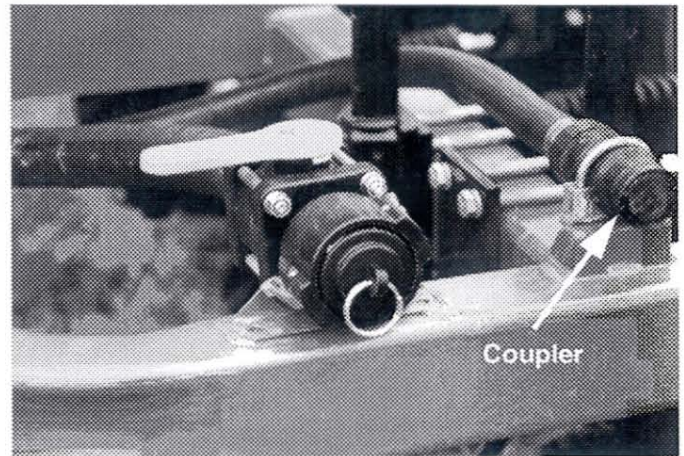

Liquid Fertilizer coupler
Figure 2-8

15880

8. Connect drive shaft by removing keeper pin on one end of the drive shaft. Slide drive shaft together and reinstall keeper pin.
9. Before operating planter be sure to place hydraulic selector valve in "Field" position. See Figure 2-7.

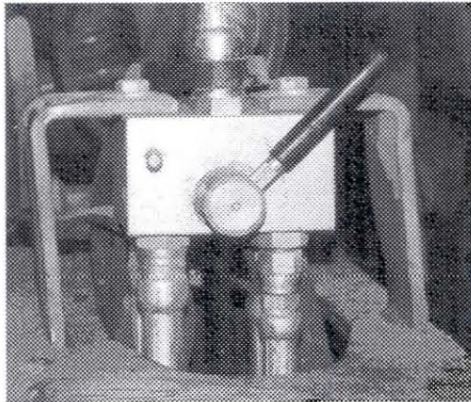

Hydraulic Selector Valve in "Field" Position
Figure 2-7

15862

Section 2 Planter Operation

! DANGER!

Shaded areas in Figure 2-9 indicate approximate danger zones. Keep away and keep others away from these areas when unfolding or folding planter and/or markers.

! DANGER!

Keep clear of overhead power lines when folding or unfolding planter and/or markers.

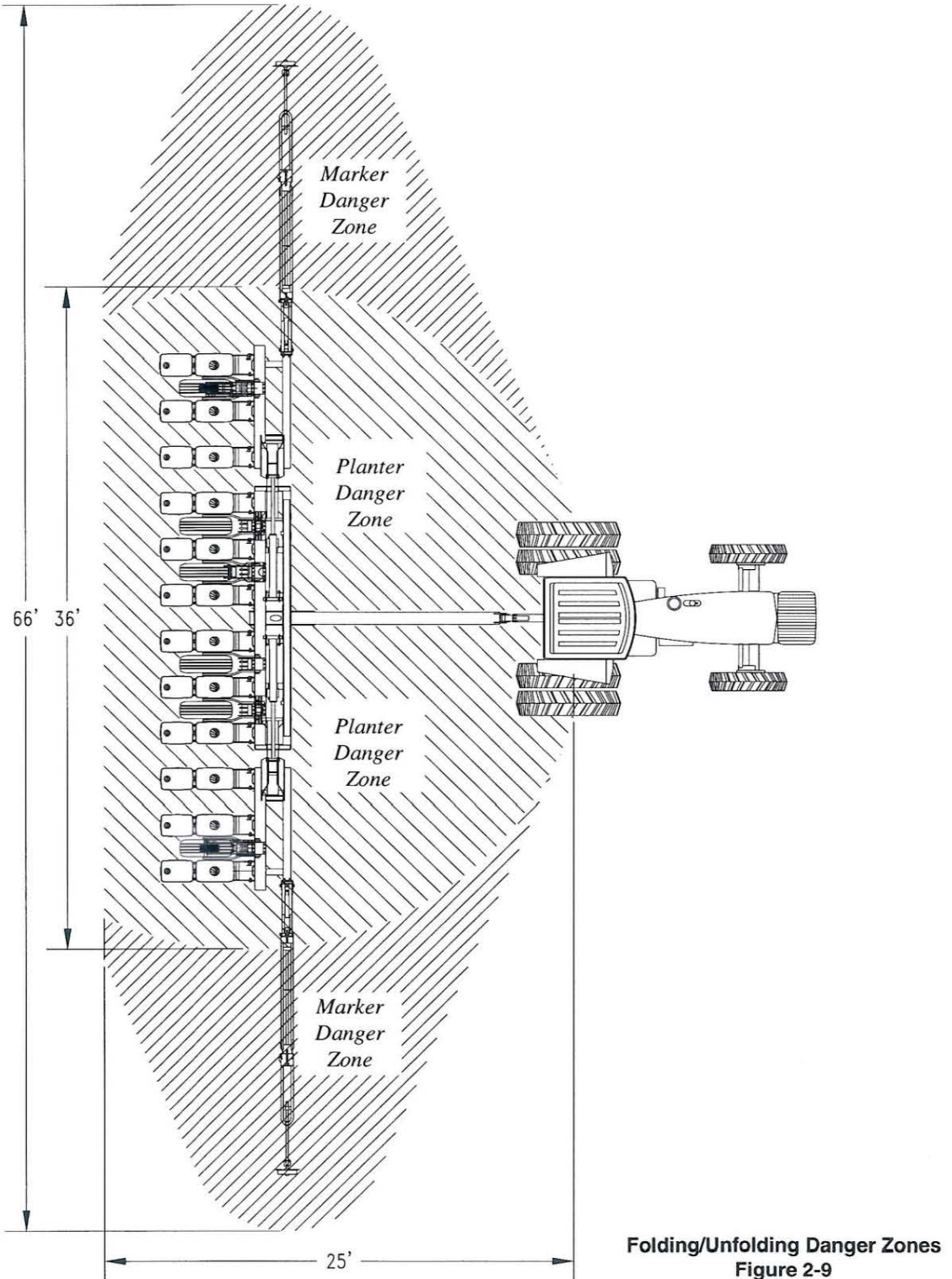

Transporting



CAUTION!

Do not exceed 20 mph maximum transport speed.

Before transporting the planter check the following items.

1. Transport only with a tractor of proper size. See *Tractor Requirements* in “**Section 1 Planter Preparation and Setup**” on page 11.
2. Hitch planter securely to tractor. Always use a locking style drawbar pin sized to match the holes in the hitch and drawbar (minimum of 1" diameter heat treated pin).
3. Attach safety chain securely to the planter hitch and the tractor with enough slack in the chain to permit turning.
4. Plug in Safety Lights with tractor lights using the standard 7-pin terminal.
5. It is recommended that the planter not be transported with full hoppers.
6. Make sure the planter is properly folded. Refer to *Folding* on page 13.
7. Any time you transport planter, be sure transport locks are in place.
8. Check to see that the tires on the planter have the proper inflation, see the *Tire Inflation Chart* in “**Section 10 Appendix**” on page 73.
9. Remember, the planter is wider than the tractor and extreme care must be taken to allow for safe clearance.

10. Transport slowly over uneven or rough terrain.



CAUTION!

Folded planter will have a high center of gravity. Use caution when traveling on an uneven surface.

11. Comply with all Federal, State and Local Safety Laws when traveling on public roads.

Leveling the Planter

For proper planter operation, it is important that the planter frame be fully lowered into the correct planting position. Achieving this position can be difficult with some attachment combinations, especially when planting in hard to penetrate soil conditions. If this situation is encountered, the following action may be warranted.

Reduce attachment down force levels. Avoid using more attachment down force than is required.

Periodically check the planter to be sure the planting units are running level.

Lower planter to planting position with the bottom of main frame tube approximately 20 to 22 in. above level ground. Refer to Figure 2-10.

When planting, the top of the hopper support panel should be parallel to the ground.

Position tractor drawbar and adjust hitch tang as required to obtain the proper planter hitch height. See *Tractor Drawbar Hookup* in “**Section 1 Planter Preparation and Setup**” on page 11.

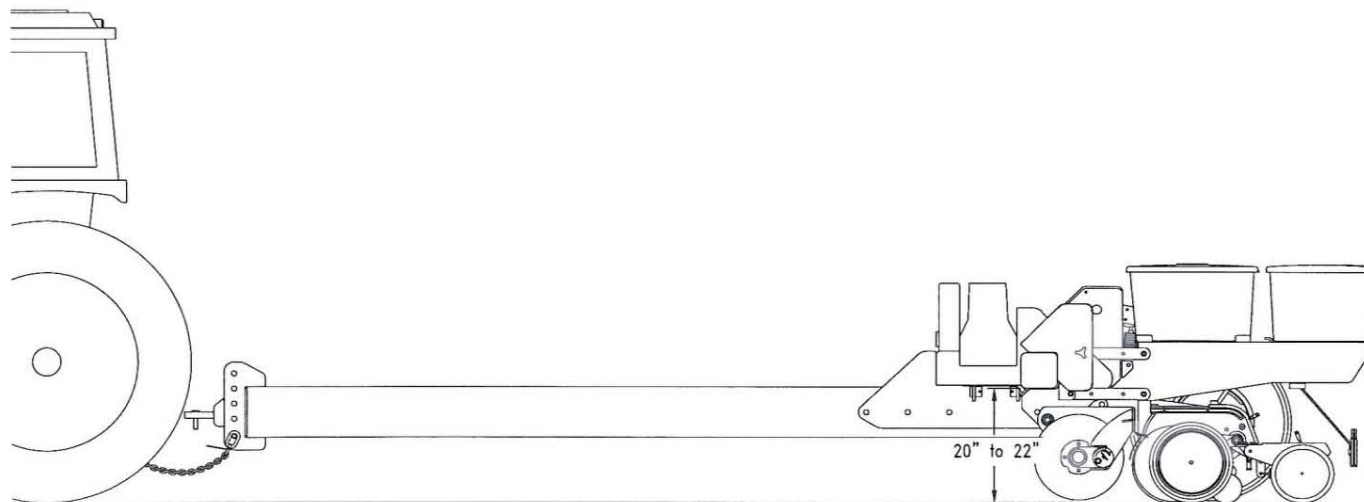

Leveling the Planter
Figure 2-10

15850

Section 2 Planter Operation

Wing/Mainframe Lowering Adjustment

If center frame and wings do not lower evenly with planter filled, adjust flow control valve located in hydraulic line near outer wing lift cylinder. Turn flow control valve clockwise to slow wing lowering. See Figure 2-11.

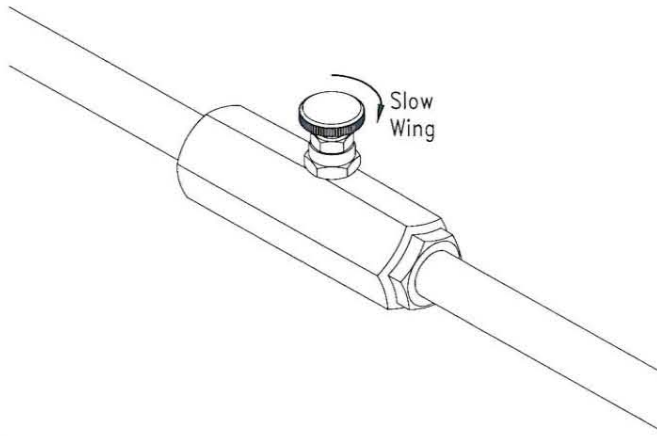

Flow Control Lowering
Figure 2-11

15895

Parking

Unhitching with the planter unfolded.

1. Remove the jack from its storage location on top of the tongue and pin it in the post located on the left side of the tongue, refer to Figure 2-12. Extend the jack until weight of the tongue is on the jack.

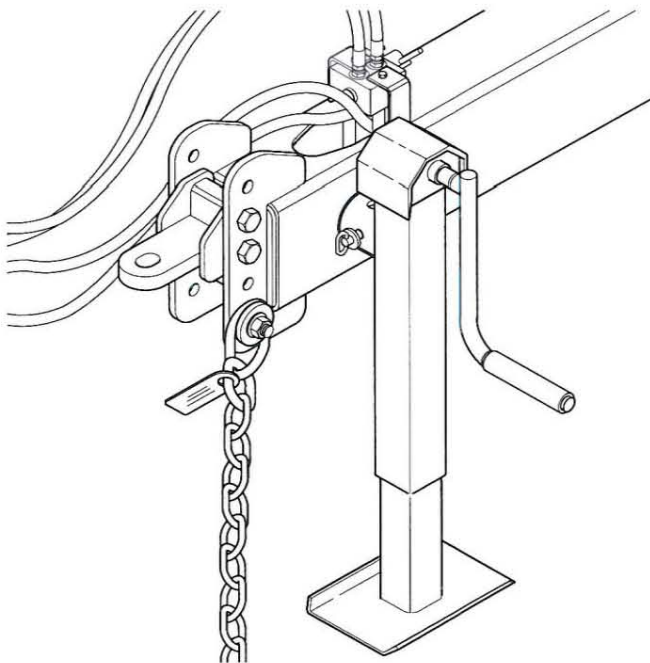

Jack in Parking Position
Figure 2-12

15817

2. Make certain that all hydraulic hoses have pressure relieved before disconnecting. Unplug the planters' hydraulic lines and electrical lines from the tractor.
3. Remove the hitch pin and safety chain from the tractor drawbar.

Unhitching with the planter folded.

1. Fold, raise, and lock the planter in the transport position.
2. Park the planter on a level, solid area.
3. Remove the jack from its storage location on top of the tongue and pin it in the post located on the left side of the tongue, refer back to Figure 2-12. Extend the jack until weight of the tongue is on the jack. If the ground is soft, place a board or plate under the jack to widen the ground contact area.
4. Make certain that all hydraulic hoses have pressure relieved before disconnecting. Unplug the planters' hydraulic lines and electrical lines from the tractor.
5. Remove the hitch pin and safety chain from the tractor drawbar.

Rephasing the Hydraulic System

! WARNING!

Escaping fluid under pressure can penetrate the skin causing serious injury. Avoid the hazard by relieving pressure before disconnecting hydraulic lines. Use a piece of paper or cardboard, NOT BODY PARTS, to check for suspected leaks. Wear protective gloves and safety glasses or goggles when working with hydraulic systems. If an accident occurs, see a doctor immediately. Any fluid injected into the skin must be surgically removed within a few hours or gangrene may result.

Refer to Figure 2-13:

The lift system on your Great Plains Pull-Type Planter is a master/slave system. All cylinders in the system are 2/way cylinders. Rephasing the system is accomplished each time the planter is lowered to the planting position. If unlevel lifting occurs, lower the planter to the ground and hold the remote lever momentarily. This time will allow oil to go from the tractor to the master; bypass to the slave, then return to the tractor.

Marker Hydraulics

! DANGER!

Never allow anyone near the planter when cycling the markers. Excessive travel speed of the markers can be dangerous and/or damage the marker assembly. The flow controls should be properly adjusted before the marker assembly is first put into use.

Refer to Figure 2-14:

The marker hydraulic system is equipped with needle valves to control how fast each marker operates. The needle valves are built into the sequence valve body. There are two hex adjustment heads, one for controlling marker

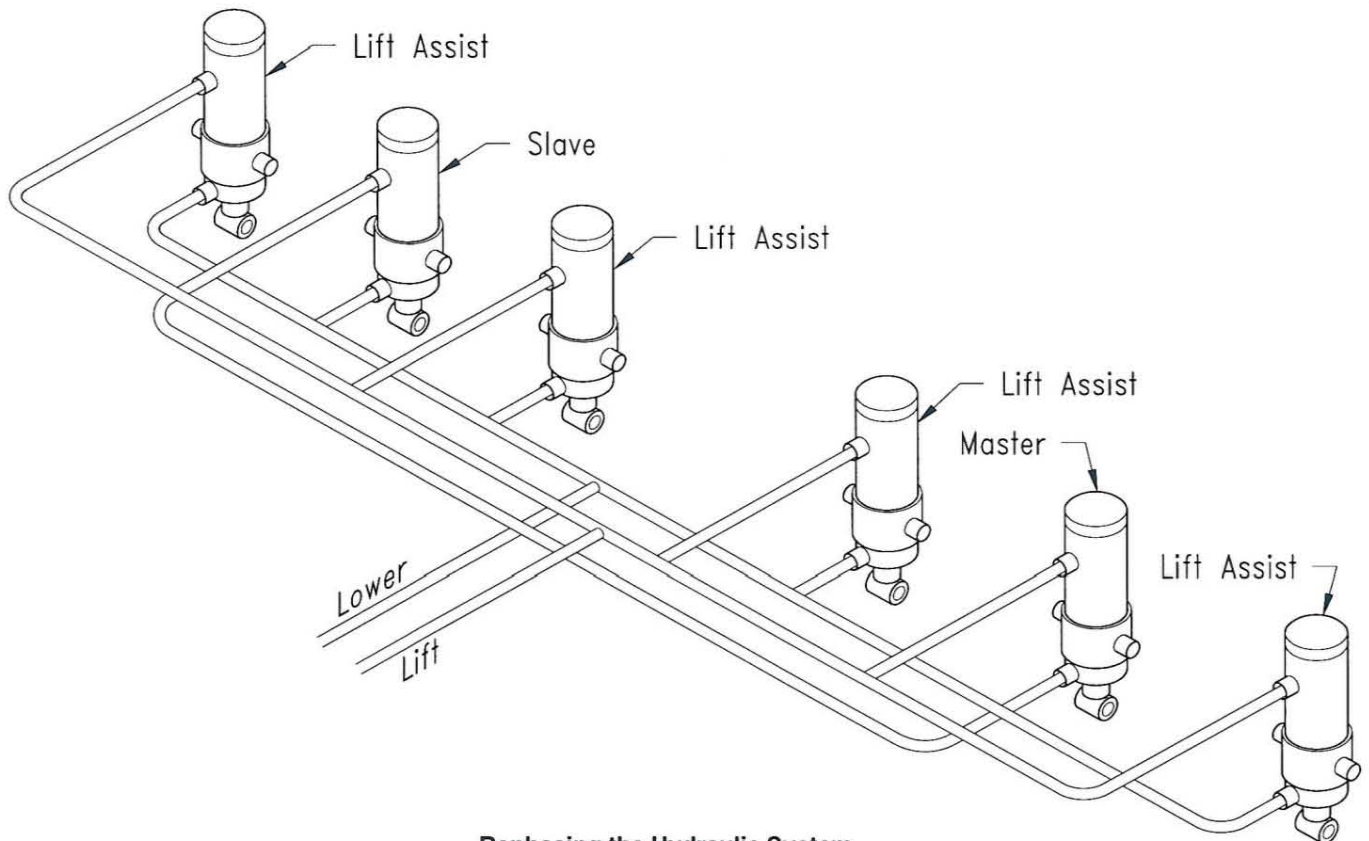

Rephasing the Hydraulic System
Figure 2-13

15806

speed up and one for controlling marker speed down. To adjust the speed of each marker, loosen jam nut, screw the needle valve clockwise to adjust the marker speed to a low setting. Fold the marker up and down a few times and recheck for pinching and kinking of hoses. With the tractor engine at an operating rpm, adjust the needle valve to limit the marker to a safe operating speed. Excessive folding speeds can cause marker damage.

WARNING!

Escaping fluid under pressure can penetrate the skin causing serious injury. Avoid the hazard by relieving pressure before disconnecting hydraulic lines. Use a piece of paper or cardboard, NOT BODY PARTS, to check for suspected leaks. Wear protective gloves and safety glasses or goggles when working with hydraulic systems. If an accident occurs, see a doctor immediately. Any fluid injected into the skin must be surgically removed within a few hours or gangrene may result.

NOTE: JIC fittings do not require high torque. JIC and O-Ring fittings do not require sealant. To avoid possible danger of cracking hydraulic fittings from over tightening, **DO NOT** use plastic sealant tape.

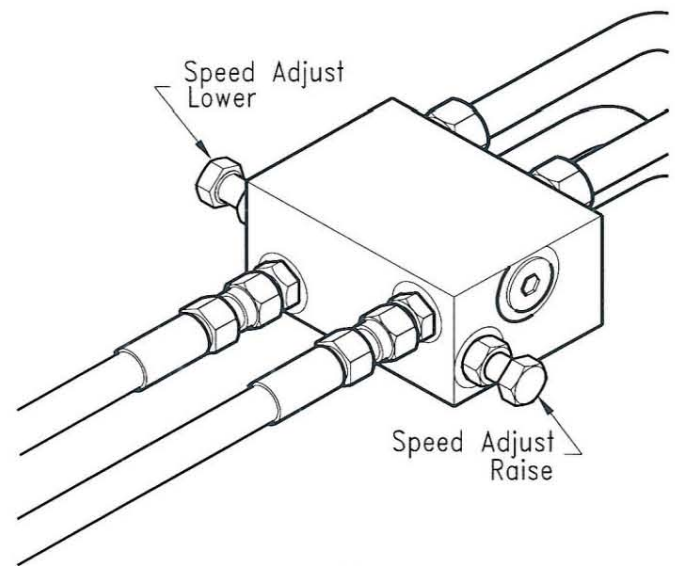

Flow Control Raise/Lower
Figure 2-14

15029

Section 2 Planter Operation

General Notes

- If both markers are required down at the same time run one marker down, momentarily start to raise it, reverse the hydraulic lever and lower the opposite marker. Holding the lever down then will force both markers down. If the markers are down they can both be raised simultaneously but they can only be lowered one at a time alternating from one side to the other.
- When oil is cold, hydraulics operate slowly. Make sure all adjustments are made with warm oil.
- On a tractor where the oil flow cannot be controlled, the rate of flow of oil from the tractor may be greater than the rate at which the marker cylinder can accept it. The tractor hydraulic control lever will have to be held until the cylinder reaches the end of its stroke. This occurs most often on tractors with an open center hydraulic system. On tractors with a closed center hydraulic system, the tractor's hydraulic flow control can be set so the tractor's detent will function properly.

Marker Transporting



DANGER!

Keep clear of overhead power lines when folding or unfolding markers. See also Figure 2-9 on page 16.

Always transport markers folded in the flat fold position.

Liquid Fertilizer Attachment



DANGER!

Agricultural chemicals can be dangerous if not selected and handled with care. Always read and follow directions supplied by the chemical manufacturer.

Squeeze Pump

Specifications:

Maximum output per hose @ 125 rpm

5/16 Diameter hose-.58 GPM
1/2 Diameter hose-1.4 GPM

Maximum speed - 125 RPM

Maximum pressure - 5 PSI

Horsepower required per hose

5/16 Diameter hose - .03 HP
1/2 Diameter hose - .05 HP

Pump Mounting and Hose Arrangement

The pump should always be mounted even with or lower than the fertilizer tank and for accurate metering, the speed should not exceed 125 RPM.

An important consideration for efficient operation of the pump is the hose arrangement. If fewer than the standard number of hoses are to be used, that is, using 4 or 5 hoses on a 6 hose pump or 10 hoses on a 12 hose pump, the reduction in the number of hoses may be made by:

1. Removing the hoses from near the center of the intake manifold and capping the intake ports.
2. Running the unneeded hoses back into the solution tank or tanks with the hoses still connected to the pump.



CAUTION!

Avoid pressure when using the quick fill attachment, see Figure 2-15. The rubber plugs installed in the manifold may be forced out under pressure.

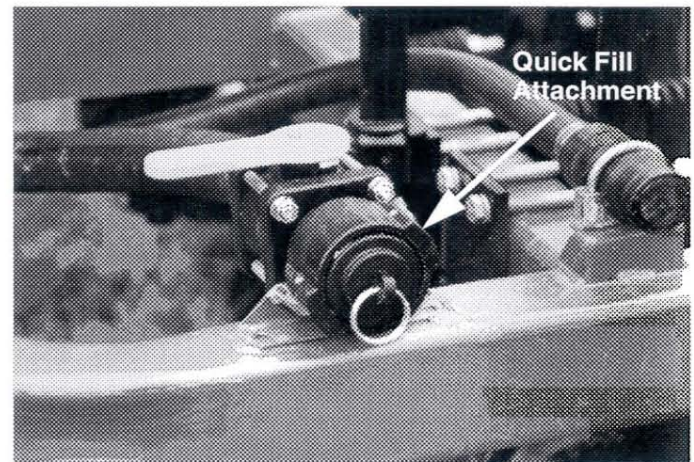

Quick Fill Attachment
Figure 2-15

15880

The discharge manifold must be in the forward position when the pump is in operation. Squeeze Pumps are shipped with the discharge manifold in the rearward or non-operating position. To reposition the manifold, loosen the wing nuts and slide the manifold forward and sideways or rearward as required and retighten nuts. See Figure 2-16.

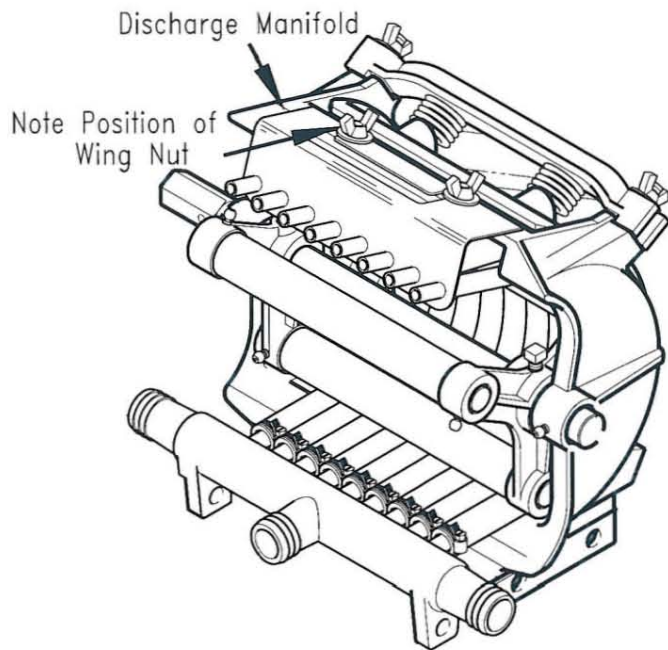

Discharge Manifold Forward Position
Figure 2-16

14949

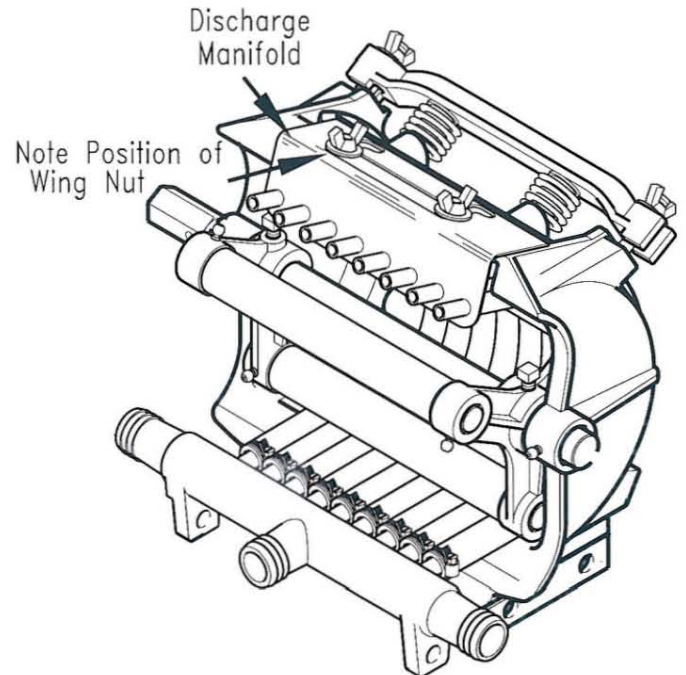

Discharge Manifold Rearward Position
Figure 2-17

14950

Shut-off valves provided at various locations should be closed to shut off flow when the planter sets overnight or for extended periods of time. It is also important to close the tank valves whenever service on the pump or hoses is being performed. To prolong the life of the hoses in the squeeze pump, the discharge manifold must be repositioned to the rearward position when not in use to prevent hose distortion. See Figure 2-17.

Section 3 Row Unit Operation

Section 3 Row Unit Operation

This planter may be equipped with either a 12 finger mechanical corn meter, see Figure 3-1, or a brush-type seed meter, see Figure 3-2.

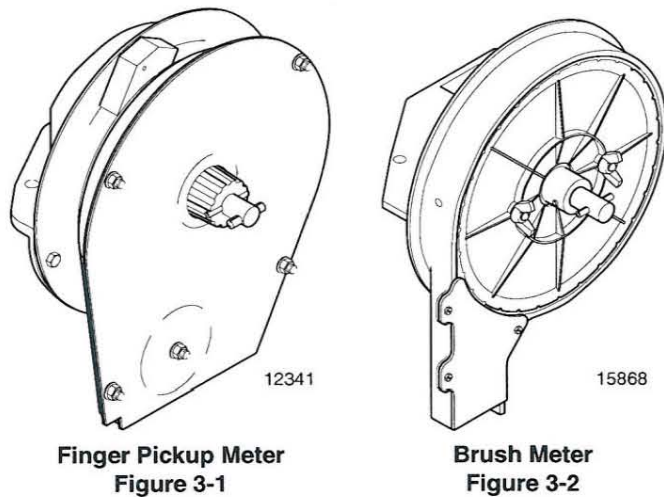

Finger Pickup Meter
Figure 3-1

Brush Meter
Figure 3-2

IMPORTANT: To extend the life and maximize efficiency of the finger pickup meter and the brush-type seed meter, sprinkle 1 teaspoon of powdered graphite on top of the seeds in the hopper, see Figure 3-3. The graphite will work its way down to lubricate the meter mechanism.

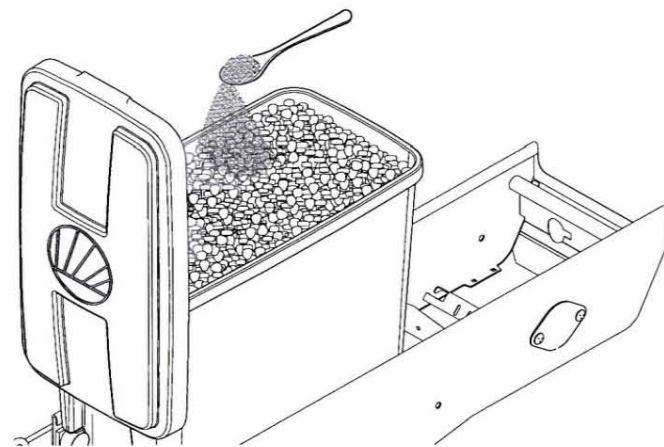

Graphite Applied to Top of Seeds
Figure 3-3

Finger Pickup Meter

Refer to the *Planting Rates for Finger Pickup Corn Meters* in “**Section 5 Planting Rate Adjustments**” on page 33 for adjusting the planting rates and sprocket combinations.

For more information on the meter, see “**Section 6 Troubleshooting**” on page 46 & “**Section 7 Maintenance and Lubrication**” on page 50.

Brush Meter

The seed discs available for use with the brush meter are as follows:

- Soybean (black color-coded): 60 cells to meter seed sizes from 2200 to 4000 seeds per pound.
- Specialty soybean (dark blue color-coded): 48 cells to meter seed sizes from 1400 to 2200 seeds per pound.
- Small milo/grain sorghum (red color-coded): 30 cells to meter seed sizes from 14,000 to 20,000 seeds per pound.
- Large milo/grain sorghum (light blue color-coded): 30 cells to meter seed sizes from 10,000 to 16,000 seeds per pound.
- High rate small milo/grain sorghum (red color-coded): 60 cells to meter seed sizes from 12,000 to 18,000 seeds per pound.
- High rate large milo/grain sorghum (yellow color-coded): 60 cells to meter seed sizes from 10,000 to 14,000 seeds per pound.
- Cotton, acid-delinted (white color-coded): 30 cells to meter seed sizes from 4200 to 5200 seeds per pound.
- Large cotton, acid-delinted (tan color-coded): 36 cells to meter seed sizes from 3800 to 4400 seeds per pound.
- High rate cotton, acid-delinted (light green color-coded): 48 cells to meter seed sizes from 4200 to 5200 seeds per pound.
- Hill-drop cotton, acid-delinted (brown color-coded): 12 cells, 3 to 6 seeds/cell, to meter seed sizes from 4000 to 5200 seeds per pound.

To install the seed disc onto the meter hub, turn the disc counterclockwise while tightening the two wing nuts that retain the disc. After the wing nuts are tight make sure the seed disc has only slight resistance when it is rotated counterclockwise.

Clean seed should be used to assure accurate seed metering. Brush meter seed discs should be removed and checked daily for buildup of foreign material in the seed meter or brushes. Foreign material, such as hulls, stems, etc., may affect seed delivery.

Refer to the *Planting Rates for Brush Meters* in “**Section 5 Planting Rate Adjustments**” on page 33 for adjusting the planting rates and sprocket combinations.

Read and follow the seed manufacturers’ recommendations when using seed treatment.

For more information on the meter, see “**Section 6 Troubleshooting**” on page 46 & “**Section 7 Maintenance and Lubrication**” on page 50.

Meter Clutches

To disengage either the seed hopper clutch or the chemical hopper clutch pull the knob and rotate 30 degrees clockwise or counter-clockwise until the points on the hex shaft align with the indentations in the end of the drive hub then release knob. See Figure 3-4.

To engage the clutches, pull and rotate the knob until the shaft aligns with the drive hub then release.

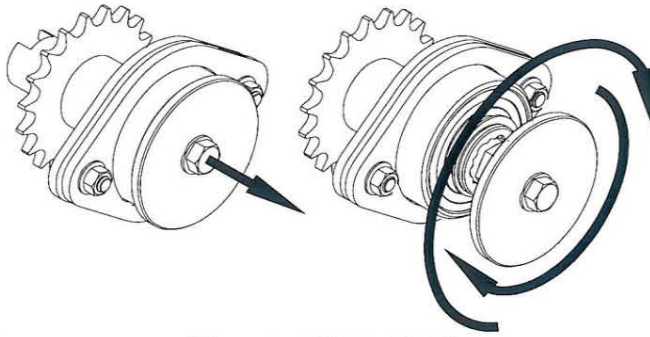

Disengage Meter Clutch
Figure 3-4 12467

Point Row Clutch

Mount the Point Row Clutch control box, Figure 3-5, at a convenient location in the tractor cab.

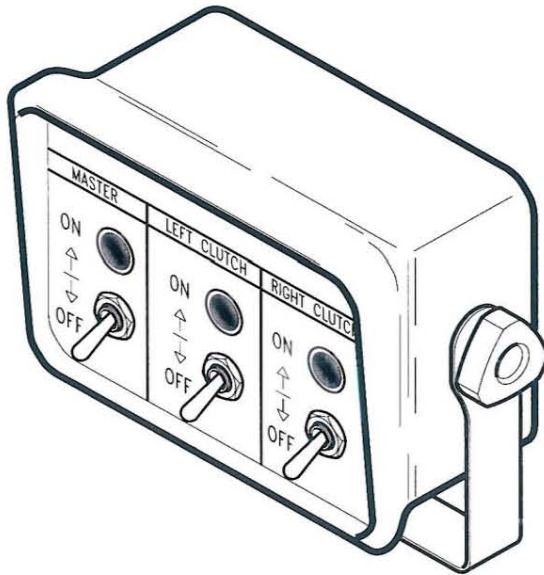

Point Row Clutch Control Box
Figure 3-5 15875

Attach all wiring connections as shown in Figure 3-6.

Refer to Figure 3-7:

The power cord must be connected directly to the battery on the tractor. The red wire is a fused connection so make sure it is connected to the positive post on the battery.

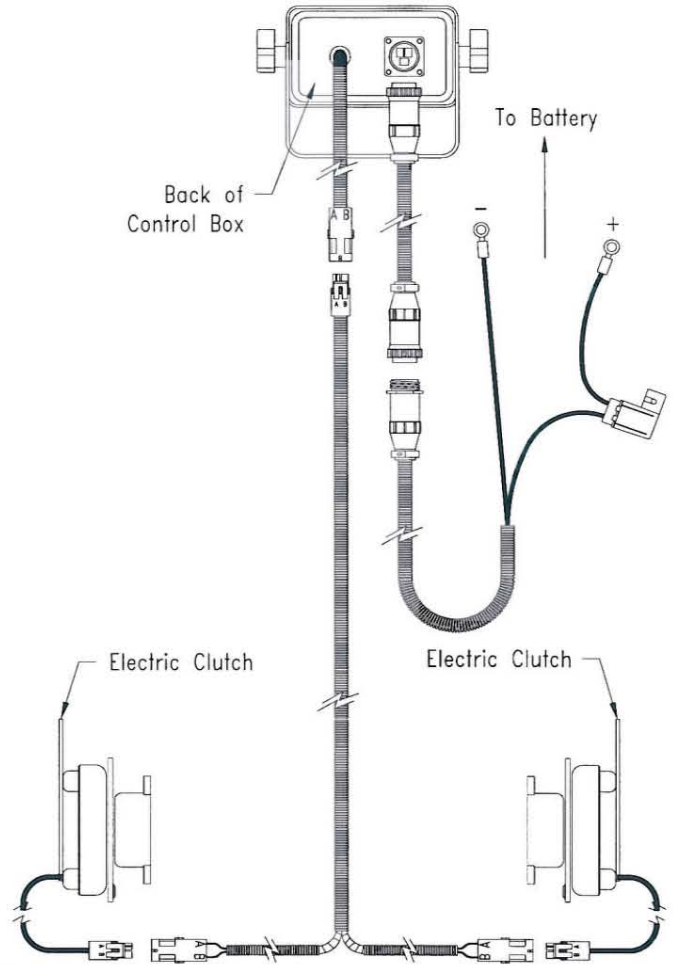

Control Box Wiring Hookup
Figure 3-6 15878

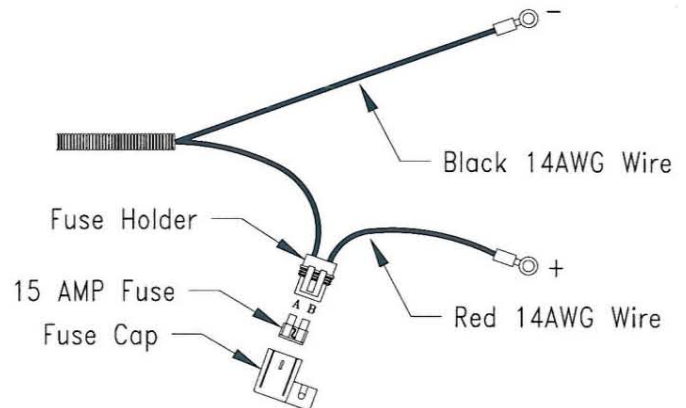

Battery Lead Connection
Figure 3-7 15876

Section 3 Row Unit Operation

Seed Hopper

The row unit is equipped with one 2-bushel translucent seed hopper.

Before filling the seed hopper, clear it of foreign objects. After filling the hopper with clean seeds always replace the hopper lid. Operating with the lids attached prevents objects from entering the hopper and also aids in keeping out moisture.

Empty the contents of the hopper periodically to avoid the collection of dirt and other materials. To remove the hopper, disengage the meter drive clutch and the hopper latch, see Figure 3-8.

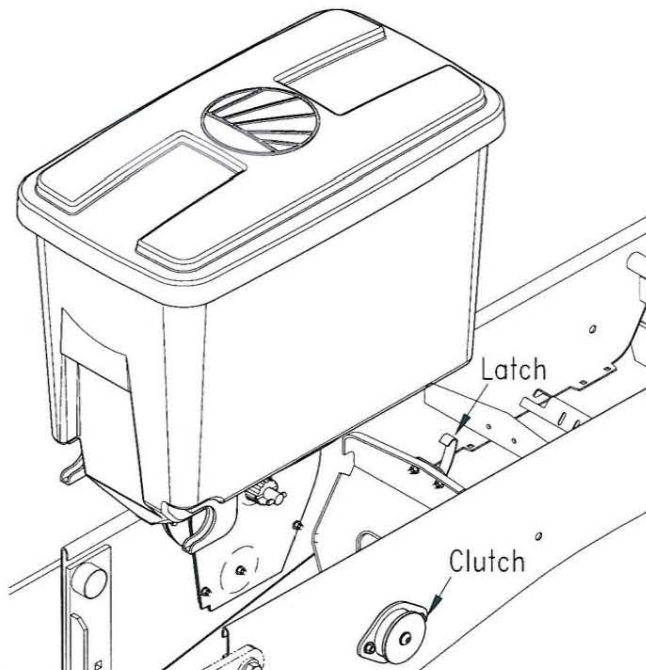

Meter Clutch & Seed Hopper Latch 15784
Figure 3-8

Chemical Hopper

The optional chemical hopper, see Figure 3-9, comes in 2 versions:

- 1 chemical meter and an approximately 70 lb. capacity translucent hopper.
- 2 chemical meters and 1 divider that separates the 70 lb. hopper into 2 compartments - approximately 35 lbs. each.

Before filling each chemical hopper clear it of foreign objects. After filling each hopper replace the hopper lid. Operating with the lid attached prevents objects from entering the hopper and also aids in keeping out moisture.

NOTE: To install Lock 'n Load[®], cut out around the Great Plains logo on top of lid. Drill through marked holes on inside of lid.

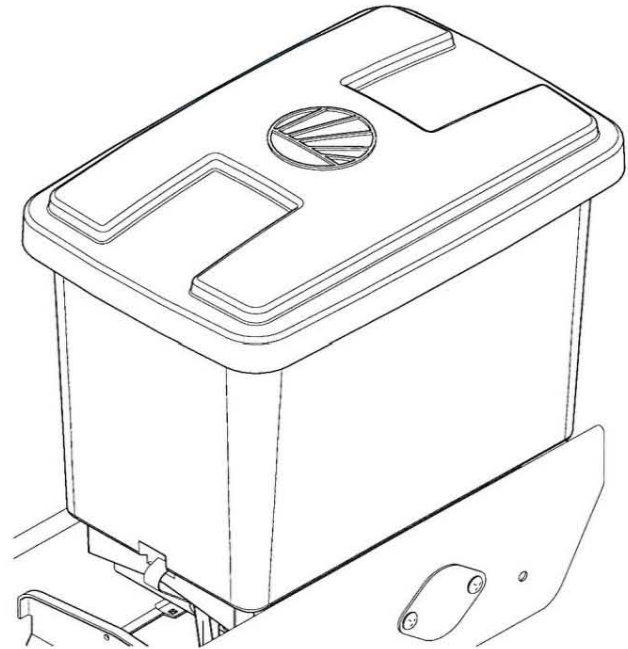

Chemical Hopper
Figure 3-9

15807

The application rate is determined by:

1. The size of the opening on the meter housing assembly.
2. The travel speed.

The size of the opening is adjustable by turning the knobs on the rear of the granular hoppers. There are 99 increments which indicate the relative application rate. The delivery rate will increase from 1 through 99. Setting 00 closes the opening completely. A fluted roller delivers the granular chemical to the adjustable opening.

The granular chemical flows through a given opening size at a nearly uniform rate regardless of rotor rpm. Therefore, SPEED has the greatest impact on application rate and resulting chemical concentration in the row.

For example, if planting speed is reduced from 6 to 3 mph, chemical concentration will nearly double since the delivery rate through the orifice remains nearly the same while the distance traveled in a given period of time has been cut in half. Therefore, twice as much chemical is placed on the ground due to the decrease in ground speed.

Section 3 Row Unit Operation

Rotor rpm will minimally change the chemical meter delivery rate unless the seed population is changed significantly (i.e. ± 25 percent or more from the original setting).

The rate charts in “**Section 5 Planting Rate Adjustments**” on page 33 are approximate, and are based on a planting speed of 5 mph. They are to be used only as a guide to determine a starting point for the meter dial setting.

Always check your rate of application as outlined in this section to be sure you are getting the desired rate.

Use the application rate and meter setting recommended by the chemical manufacturer as a starting point for the meter dial setting.

If the meter setting is not available from the chemical manufacturer, use the charts in “**Section 5 Planting Rate Adjustments**” on page 33 as a starting point for the meter dial setting.

IMPORTANT: Because the available chemical materials vary widely in consistency and composition, their “flowability” is affected by temperature and humidity conditions. It is important to calibrate each individual meter to the particular chemical being used.

To determine the application rate and starting meter setting, proceed as follows:

The chemical manufacturer may recommend the rate of application for granular chemicals in the following ways:

1. Ounces per 1000 linear row feet.
2. Pounds per acre for a given band width and row spacing.
3. Pounds per acre for complete (broadcast) coverage.

When the chemical manufacturer recommends ounces per 1000 linear row feet or pounds per acre for a given band width and row spacing, proceed to the chemical manufacturer’s recommended meter setting or to the meter setting recommended in the rate charts.

When the chemical manufacturer recommends pounds per acre for complete (broadcast) coverage only, it is necessary to reduce the pounds per acre to apply for your band width and row spacing. This will give you the same chemical concentration in the band area as the chemical manufacturer recommends for complete (broadcast) coverage.

Use the following formula to find the pounds per acre for your band width and row spacing.

NOTE: We recommend you actually measure the band width applied in your conditions and use this width in your application rate calculations.

$A \times B/C =$ Delivery rate per acre for a given band width and row spacing.

A - Chemical manufacturers recommended rate in pounds per acre for complete (broadcast) coverage.

B - Band width in inches.

C - Row spacing in inches.

Example: The chemical manufacturer recommends 20 lb/acre for complete broadcast coverage. The band width is 14 inches. The row spacing is 30 inches.

$20 \times 14/30 = 9.3$ lb. per acre.

The required delivery rate for 14 inch bands and 30 inch row spacing would be 9.3 lb/acre. Set meter setting recommended for 9.3 lb/acre broadcast coverage.

Delivery of 9.3 lb/acre of chemical in a 14 inch band will provide the same chemical concentration on the soil surface as delivery of 20 lb/acre broadcast coverage.

Proceed to chemical manufacturer’s recommended meter setting or to the meter setting recommended in the rate charts in this section which will deliver 9.3 lb/acre.

To check the exact number of lb/acre of chemical that will be delivered, attach a plastic bag to each chemical diffuser, lower the planter, and proceed as follows:

Drive 500 feet at planting speed. Weigh the chemical in oz. that was caught in one bag. Multiply that amount by the factor shown to determine lb. per acre.

Check the chemical caught in each bag in the same manner.

Lb. Per Acre Factor for Given Row Width

Row Width	Factor
38 inch	1.7
36 inch	1.8
30 inch	2.2

Example: Assume you are planting 38 inch rows and you caught 5.6 ounces in one bag (one row).

5.6 ounces times 1.7 (factor for 38 inch rows) equals 9.5 lb. per acre.

If the desired amount is not obtained for each unit with the first setting, turn the metering knob and repeat the check until desired amount is delivered.

NOTE: If a significant difference in rate is observed between rows, the meter dial mechanism may require recalibration.

Empty the contents of each hopper periodically to avoid the collection of dirt and other materials. To remove the hopper, disengage the meter drive clutch and unlatch front of hopper.

Section 3 Row Unit Operation

Recalibrating Insecticide/Herbicide Meter

Refer to Figure 3-10:

If it should ever become necessary to recalibrate the granular meter on the insecticide/herbicide hopper, proceed as follows:

1. Remove and empty hopper and turn hopper upside down.
2. Turn hopper knob to "10".
3. Loosen screws (#1) in metering gate.
4. Insert calibration tool (#2).
5. Readjust dial to "04".
6. Slide gate (#3) to tool.
7. Retighten screws.
8. Reinstall hoppers, refill and check per previous instructions.

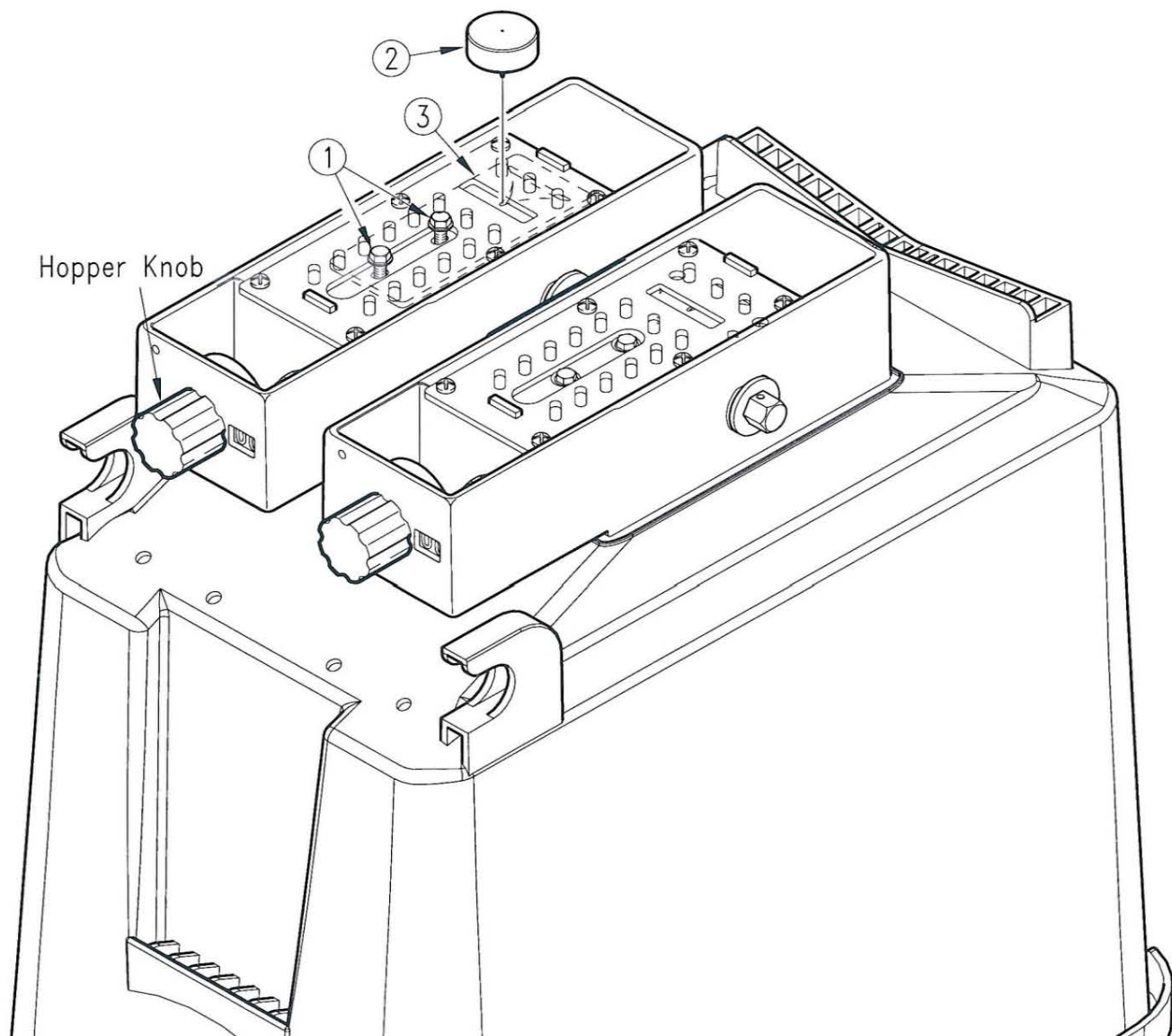

Recalibrating Chemical Meter
Figure 3-10

15785

Section 4 Adjustments

Marker Disk Adjustments

The aggressiveness and the mark left by the disk may be changed by two methods:

Refer to Figure 4-1:

1. Disk Angle

To change the angle of cut, loosen the two bolts (1), rotate the disk assembly and retighten.

2. Direction of Cut

The disk may be mounted to throw dirt either in or out which will give different marks in different soil conditions. To change the direction of cut:

- Reverse the blade and depth band by remounting the four lug bolts on the disk hub.
- Reverse the angle of the assemble by removing the adjustment bolts and turning the spindle assembly one half turn. Reinstall and tighten all bolts.

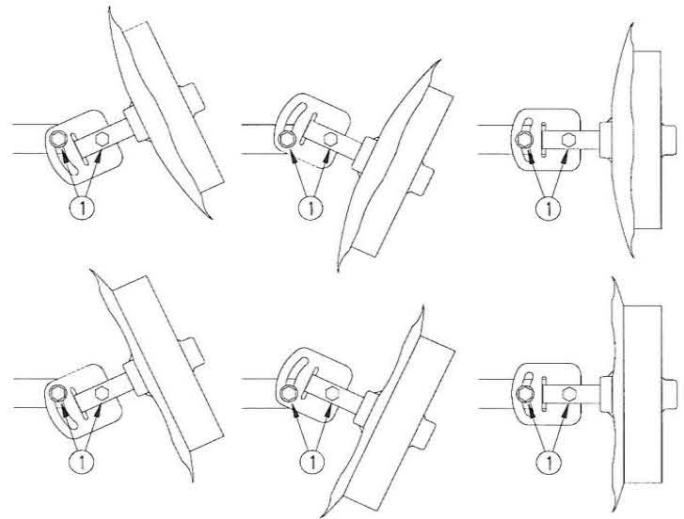

Disk Angle and Direction of Cut
Figure 4-1

15834

Refer to Figure 4-2:

Marker width adjustment is made by loosening the marker tube u-bolt (#1) and sliding marker tube in or out to the desired width.

Dimension (A) is measured from the center line of the planting unit to the marker disk.

The approximate dimension (A) is 360" and should be checked in the field.

After adjusting marker, tighten u-bolt.

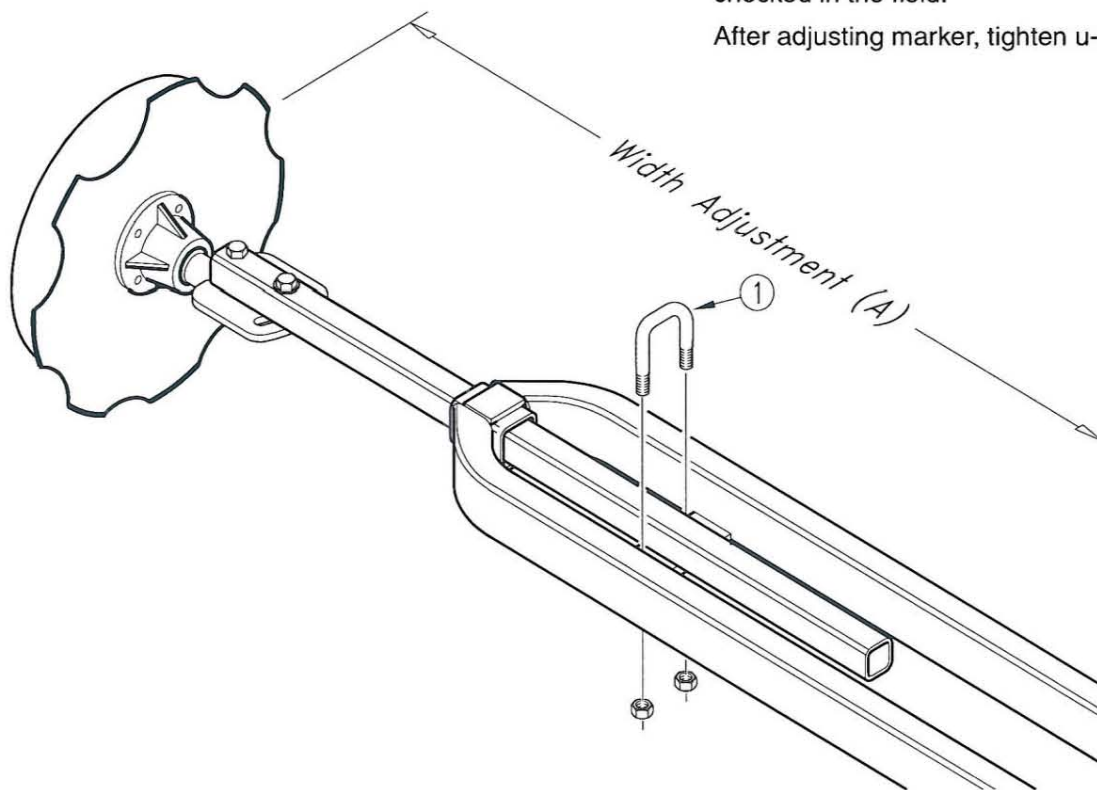

Marker Disk Adjustment
Figure 4-2

15835

Section 4 Adjustments

Contact Drive Wheel Spring

There are two down pressure springs, see Figure 4-3, on each contact drive wheel. The down pressure is factory preset and should need no further adjustment.

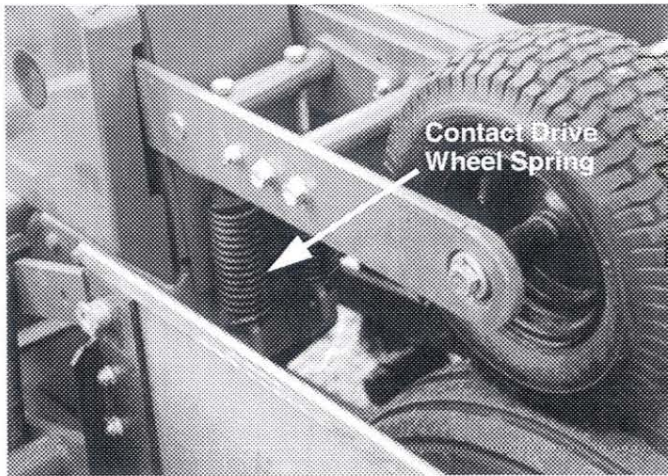

Contact Drive Wheel Spring
Figure 4-3 15882

Seed and Chemical Meter Drive Adjustments

The alignment between the meter clutch and the input shaft is important. If there is misalignment the meter will not function properly. Excessive wear and damage can also occur to the meter housings. When replacing the meter the vertical and horizontal alignment should be checked.

Check for Vertical Alignment

Refer to Figure 4-4:

1. Latch the appropriate hopper into place on the support.
2. The roll pin in the end of meter input shaft should be centered (equal distances of the roll pin should protrude from both sides of the shaft).
3. Rotate the input shaft so that the roll pin is vertical.
4. Rotate the drive coupler so that the slots are vertical.
5. Release the clutch to engage the drive coupler with the input shaft.

If the alignment is correct the coupler will engage with the shaft freely and the roll pin will extend equally on each side of the coupler. Disengage the clutch and check the horizontal alignment.

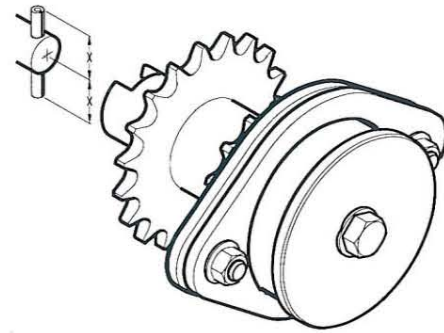

12417

Vertical Alignment
Figure 4-4

Check for Horizontal Alignment

Refer to Figure 4-5:

1. Latch the appropriate hopper into place on the hopper support.
2. The roll pin in the end of meter input shaft should be centered (equal distances of the roll pin should protrude from both sides of the shaft).
3. Rotate the input shaft so that the roll pin is horizontal.
4. Rotate the drive coupler so that the slots are horizontal.
5. Release the clutch to engage the drive coupler with the input shaft.

To adjust alignment:

- With the hopper in place loosen the two 5/16" nuts.
- Engage the clutch to the meter input shaft.
- Align clutch with shaft and tighten 5/16" nuts to torque values in the *Torque Values Chart for Common Bolt Sizes* in "Section 10 Appendix" on page 73.

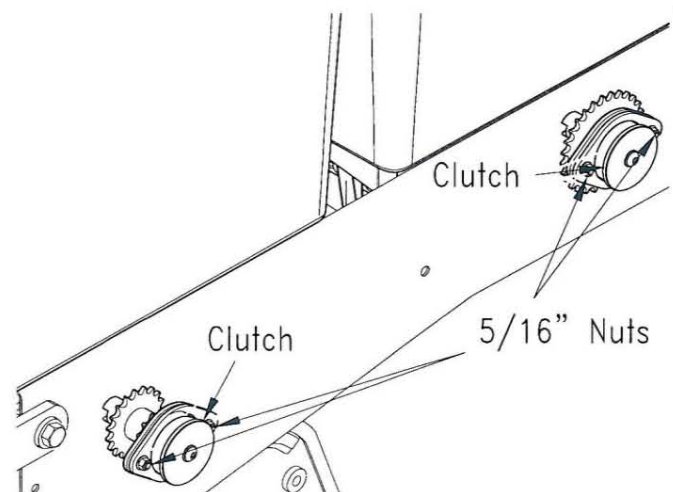

Horizontal Alignment
Figure 4-5

15897

Section 4 Adjustments

Depth Adjustment

The planting depth of the row unit is controlled by 2 walking gauge tires located next to the disks.

Adjust the planting depth as follows:

1. Raise the planter to remove weight from the gauge tires.

Raise the T-handle and move it forward to decrease the planting depth, see Figure 4-6. Moving the handle rearward increases the planting depth. Small increments of depth adjustment can be made by walking the T-handle from side to side.

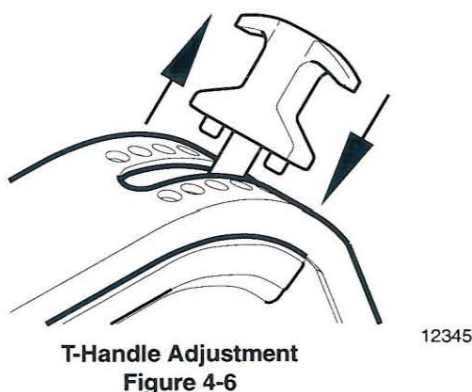

After one row is set to the desired depth, move the T-handle on the other rows to the same location.

Down Force Row

Standard Spring Package

The standard down force spring package, consists of 2 adjustable springs applying approximately 100-200 lbs. of down force.



CAUTION!

Adjust spring pressure only with planter in raised position.

Optional Heavy Duty Spring Package

The heavy duty spring packages consist of 2 additional springs. The heavy duty package can be adjusted from approximately 200 to 400 lbs. of down force.

Spring Adjustments

- All spring adjustments must be made with the planter in the fully raised position.

NOTE: The maximum down force stated before is reached when the parallel arms are all the way up.

- The spring package is adjustable from 90 lbs. to 325 lbs. of down force when the parallel arms are horizontal.

Consult the *Down Force Pressure Chart* to obtain the desired down force.

NOTE: To adjust the spring tension, lift the plunger by pulling up on the roll pin handle and sliding the handle adjustment assembly into the appropriate hole, see Figure 4-7.

- Two springs can be purchased at your Great Plains Dealer to make the standard package into a heavy duty package or two springs can be removed from the heavy duty package to make a standard package. Add or subtract springs by removing the cotter key at the end of the spring pivot rod. Slide the rod inward to add or remove a spring from each side. Then attach or remove the other spring end on the hex bar support. Reinstall the spring rod and snap ring on each side.

Down Force Pressure Chart

Refer to Figure 4-7:

To Obtain This * Down Force	Use This # of Springs	In This Hole
90 lbs.	2	A
105 lbs.	2	B
125 lbs.	2	C
140 lbs.	2	D
160 lbs.	2	E
185 lbs.	4	A
215 lbs.	4	B
245 lbs.	4	C
285 lbs.	4	D
325 lbs.	4	E

* Force when arms are parallel.

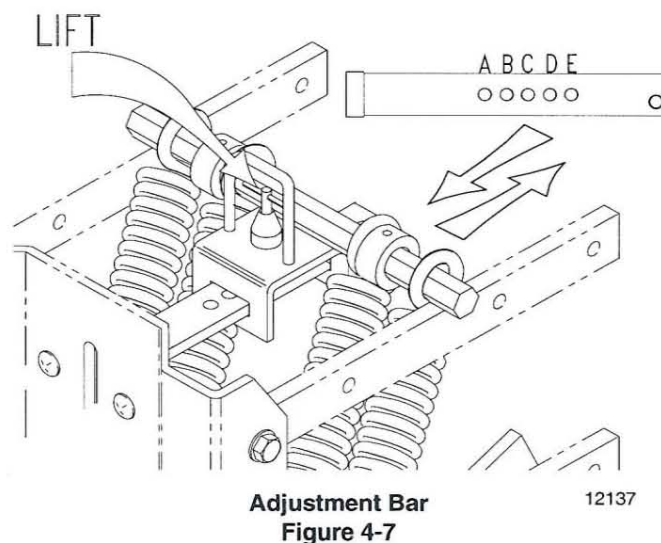

Section 4 Adjustments

Row Unit Mounted Coulter Adjustment

The optional coulter allows the planter to penetrate tough ground conditions. It is recommended that either the standard or heavy duty spring package be used in conjunction with this coulter.

Coulter Adjustments

Refer to Figure 4-8:

1. To adjust the coulter vertically, loosen the 3/4" jam nut (#1) and the 3/4" x 3" long hex bolt (#2).
2. By turning the cam hex (#3), rotate the cam casting to set the desired height. For wavy coulter blades, it is recommended that the coulter blade should be run even to 1" below the disks on the row unit.
3. Tighten the bolt and jam nut. Refer to *Torque Values Chart for Common Bolt Sizes* in "Section 10 Appendix" on page 73.

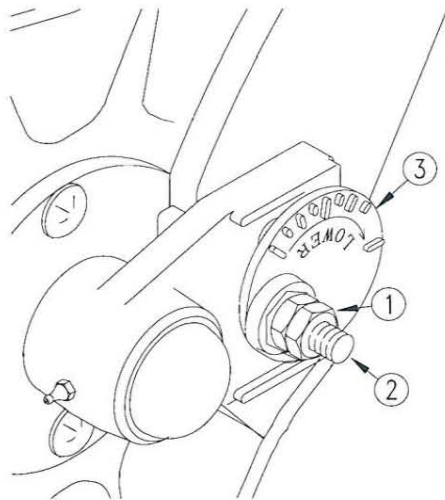

Coulter Adjustment
Figure 4-8

15053

1 x 12 Closing Wheel Adjustments

The 1 X 12 closing wheel option can be adjusted for down force, alignment, and offset.

Closing Wheel Down Force Adjustment

Adjust the closing wheel down force to permit proper closing of the seed trench. It is recommended to start with the T-handle in the first of 4 notches, see Figure 4-9.

If the seed trench is not closing move the handle to the next notch back and try again. Keep moving the handle back until the seed trench is closing, by doing this eliminates unnecessary down force and compaction. In some field conditions, the T-handle can be left in the forward slot to minimize down force.

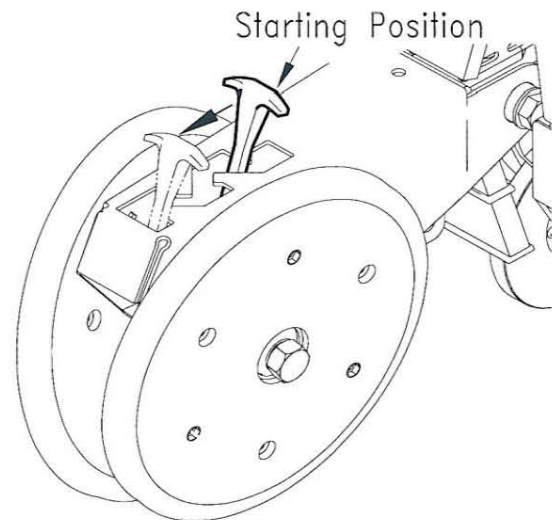

Closing Wheel Adjuster
Figure 4-9

12346

Closing Wheel Alignment

Refer to Figure 4-10:

If one closing wheel is running in the seed trench or the wheels are not centered over the seed trench, adjust the closing wheels as follows:

1. Raise the planter slightly to remove weight from the closing wheels.
2. Loosen the two 1/2" bolts.
3. Turn the press wheel adjuster left or right to center the wheels over the seed trench.

Tighten the 1/2" bolts to the correct torque values in the *Torque Values Chart for Common Bolt Sizes* in "Section 10 Appendix" on page 73.

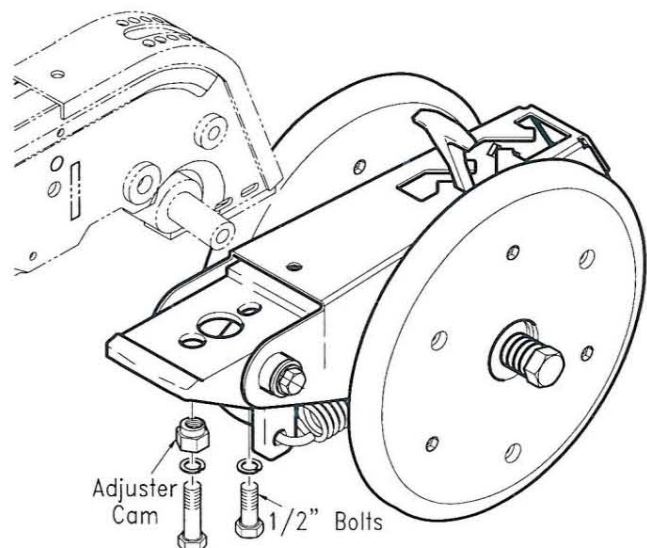

Closing Wheel Alignment
Figure 4-10

12418

Section 4 Adjustments

Closing Wheel Offset

The 1x12 wheels can be offset to help prevent trash from plugging the closing wheels. If the closing wheels are not offset, the wheels should be located in the front holes of the press wheel arm.

To offset the wheels, do as follows:

1. Raise planter slightly to remove weight on the closing wheels.
2. Remove the 3/4" bolt holding the wheel, see Figure 4-11.
3. Move the wheel to the rear hole and attach with the 3/4" bolt. Tighten the bolt to the correct torque value listed in the *Torque Values Chart for Common Bolt Sizes* in "Section 10 Appendix" on page 73.

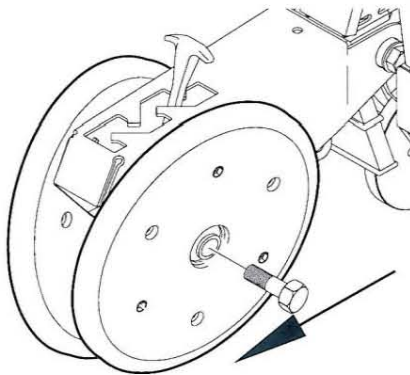

Closing Wheel & Offset
Figure 4-11

12347

Closing Disk Adjustments

The closing disk options consists of two disks and a 6 1/2 x 12 press wheel. The disk down pressure can be adjusted to provide closing of the seed trench.

To select one of four down pressure settings, ratchet the spring cam to the next cam height by turning the head of the support bolt clockwise. Refer to Figure 4-12.

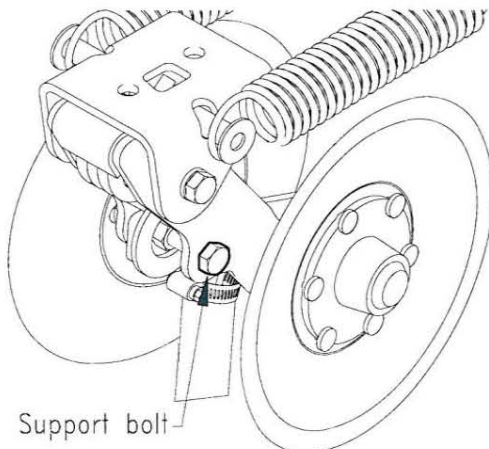

Closing disk & Tube Holes
Figure 4-12

15830

Closing Disk Tube Shield

Refer to Figure 4-13:

To prevent clogging in insecticide hoses:

1. Clamp closing disk tube shield to closing disk with hose clamp provided.
2. Insert insecticide hose (#1) inside the closing disk tube shield (#2) as shown. When unit is picked up, the insecticide hose should be about 1/4" above the bottom of the shield.

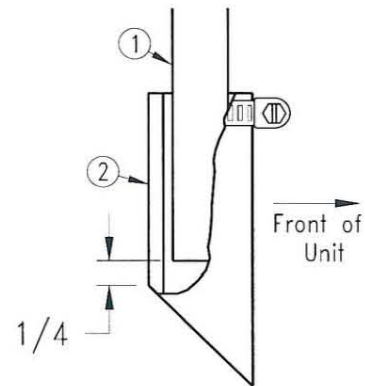

Closing Disk Tube Shield
Figure 4-13

15717

Ridge Planting

Refer to Figure 4-14:

Lowering the wheel for ridge planting is accomplished by inverting the cylinder mounting blocks.

To invert, first block under the frame to remove weight from tires, remove the four 5/8" cap screws. Invert mounting blocks and install cap screws. Torque per specifications, see *Torque Values Chart for Common Bolt Sizes* in "Section 10 Appendix" on page 73.

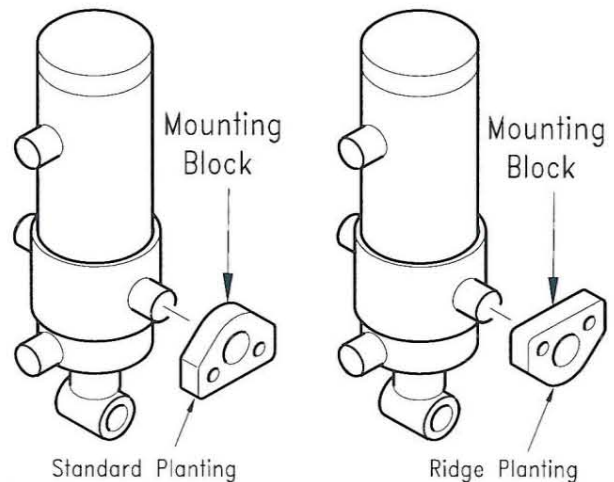

Ridge Planting Adjustment
Figure 4-14

14958

Section 4 Adjustments

Liquid Fertilizer Adjustments

Squeeze Pump Hose Alignment

Refer to Figure 4-15:

If 'A' or 'B' hose (end hoses) should run off the back, re-align hoses as follows:

1. 'A' Hose - Loosen hose clamp on intake manifold and twist hose 1/4 turn in a counter-clockwise direction.
2. 'B' Hose - Loosen hose clamp on intake manifold and twist hose 1/4 turn in a clockwise direction.
3. Retighten hose clamp.

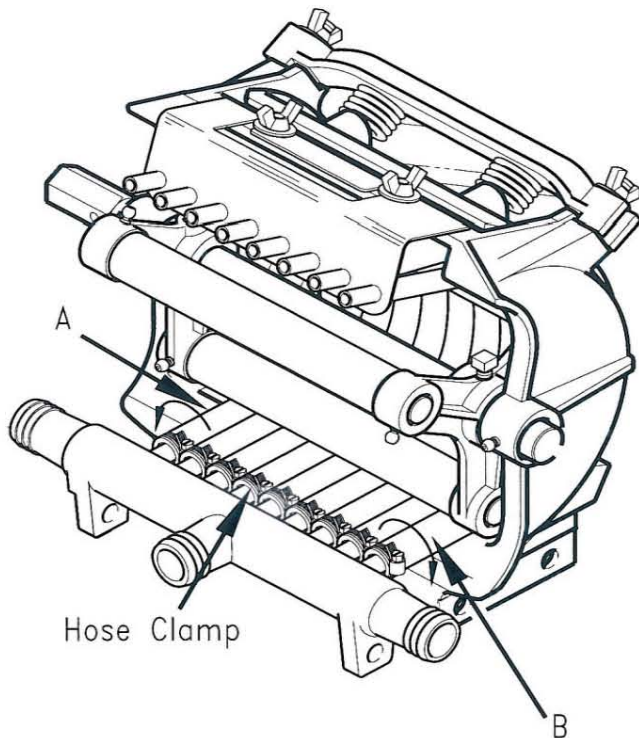

Hose Alignment
Figure 4-15

12402

Tire Scraper (Optional)

Some soil types may require the use of the optional tire scraper. The scraper prevents an excess of mud from building up on lift tire that may hamper the contact drive tire. Adjust the scraper so it does not contact the tire. See Figure 4-16.

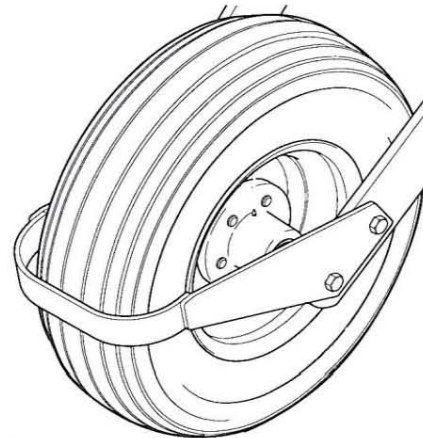

Tire Scraper
Figure 4-16

15027

Seed Lok[®] (Optional)

The Seed Lok[®] option provides additional seed to soil contact. The Seed Lok[®] is spring loaded and does not require adjusting. In some wet and sticky conditions the wheel may accumulate soil and may require removal of the Seed Lok[®] until conditions improve.

The Seed Lok[®] is attached to the shank with a 1/2" clevis pin, see Figure 4-17. To remove the Seed Lok[®], remove the clevis pin and pull down on the Seed Lok[®] mount.

Reattach in the reverse order.

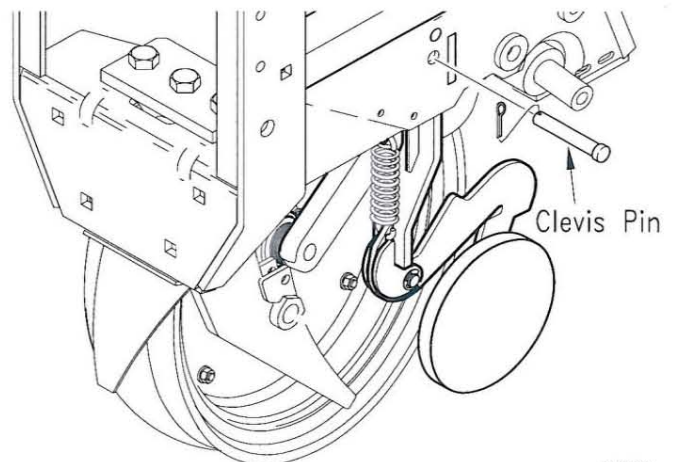

Seed Lok Assembly
Figure 4-17

15883

Section 5 Planting Rate Adjustments

This section discusses the adjustments and settings for seeding and chemical rates.

Planting Rates

Please read the following sections. Complete understanding of this process will help to prevent problems.

Transmission Adjustment

Planting population changes are accomplished by setting the sprocket transmission. By changing the combination of sprockets the desired planting populations can be achieved.

2 to 1 Drive Reduction

The 15/28 tooth drive sprocket located on the inner side of the contact drive wheel assembly will give you a 2 to 1 drive reduction, and will reduce the planter transmission speed to reduce planting rates by approximately 1/2. See Figure 5-1.

IMPORTANT: After each sprocket combination adjustment, make a field check to be sure you are planting at the desired rate.

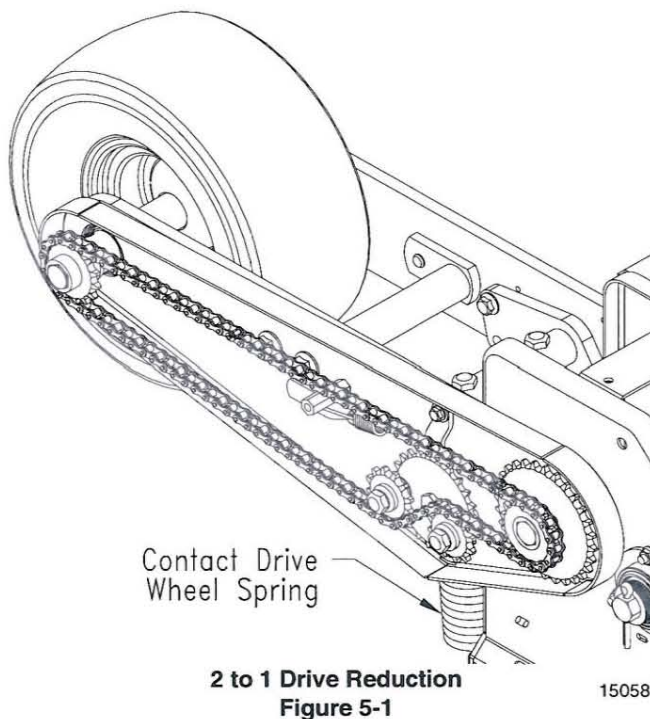

2 to 1 Drive Reduction
Figure 5-1

To change the sprocket combination refer to *Planting Rates for Finger Pickup Corn Meters* on page 36 and *Planting Rates for Brush Meters* on page 37:

1. Select the sprocket combination for your planting population.
2. Remove the cover from the transmission by loosening

the knob on the cover.

3. Release the spring tensioner on the idler, see Figure 5-2.

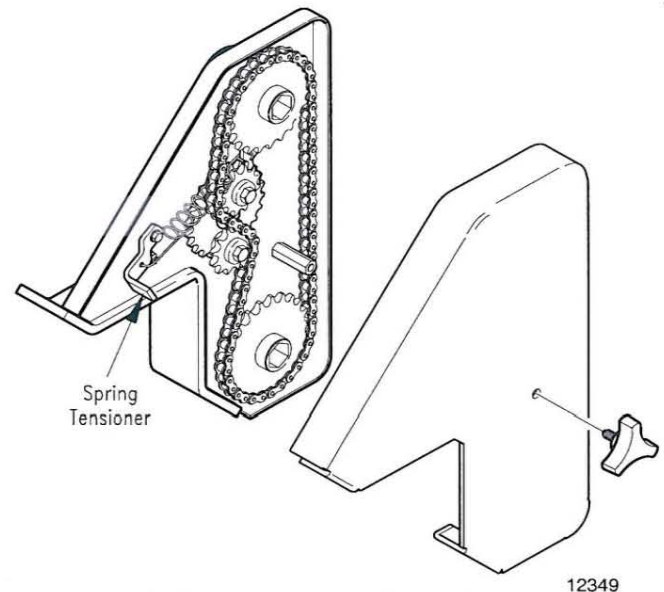

Spring Tensioner on Transmission
Figure 5-2

4. Remove the chain and sprockets.
5. Exchange the sprockets with the desired sprockets, selected in step 1, on the storage bracket.

Note: When not in use, keep all extra sprockets on the storage bracket.

6. Place the sprockets on the drive/driven shafts.
7. Loop the chain over the sprockets and between the 2 idlers.
8. Turn the idler plate counter-clockwise (ccw) to take up the slack. Hook the spring onto the idler plate. Rotate the tensioner over center. If the chain is too loose, hook the spring onto the next notch in the plate.
9. Replace the transmission cover and hand tighten the knob.

Checking Planting Population

After setting the transmission, ALWAYS check the planting population in the field.

Follow these steps to check the planting population:

1. Tie up 1 or more closing discs and wheels with a chain or heavy wire to the hopper support. Releasing the spring pressure on the discs and wheels will make this easier. Adjust the planting depth to a shallow setting. It may be necessary to tie up the Seed Lok® wheels so that the seeds are easier to find.

Section 5 Planting Rate Adjustments

2. Plant at a normal speed for a short distance.
3. Measure 1/1000 of an acre. For 30" row planter 1/1000 of an acre is 17' 6".
4. Multiply the number of seeds counted by 1000. This gives you total population.

Example: (for one row)

- 30" row spacing
- 17' 6" of seed trench measured off
- 24 seeds counted in measured distance

24 Seeds Counted X 1000 =
24,000 Plant Population Per Acre

If the planting population is significantly different than the desired planting population, make the following checks:

- Check the sprocket combination in the transmission, refer to the *Planting Rates for Finger Pickup Corn Meters* on page 36 and *Planting Rates for Brush Meters* on page 37.
- Check the tire pressure in the gauge tires and drive tires in "**Section 10 Appendix**" on page 73.
- Check for meter malfunction, see "**Section 6 Troubleshooting**" on page 46.

Planting Recommendations

To get the best planting results, follow these recommendations:

- Plant at 5 mph
- Add 1 teaspoon of graphite to each seed hopper.
- Maintain tire pressure in the gauge tires and drive tires.
- Replace worn meter parts.

Drive Wheel Slippage

Another item that may cause the actual rates of seed or fertilizer to differ from the delivery rates shown in the operator's manual is the amount of drive wheel slippage.

While a certain amount of wheel slippage is normal, excessive drive wheel slippage may cause undesirable changes in the actual rates.

Excessive drive wheel slippage may be caused by binding or poorly lubricated parts, misaligned bearings or caked material in the pesticide or fertilizer hoppers.

In addition, down pressure springs, coulters, tine tooth attachments, or any other attachment that removes frame weight from the drive wheels, may contribute to drive wheel slippage and lower than expected rates.

If in-field checks indicate that the planter is planting at a rate significantly different than the seed transmission rate chart indicates, investigate the following in the order listed:

- Ensure that ALL transmission sprockets are set accord-

ing to the rate chart.

- Excessive unit bounce can cause low population and reduced spacing control. Reduce excessive unit bounce by increasing unit down force, or drive slower.
- Ensure that the planter drive wheel slippage is close to normal. Variations in drive wheel slippage can be caused by crop residue, tire inflation pressure, soil conditions and unit down force.

Adjusting Granular Chemical Rates

The optional chemical applicators are adjusted by varying the opening on the chemical meter housing. The field check is very important because temperature, humidity, speed, ground conditions, flowability of chemicals, and obstructions affect the application rate.



DANGER!

Agricultural chemicals can be dangerous if not selected and handled with care. Always read and follow directions supplied by the chemical manufacturer.

To adjust the chemical rate do as follows:

1. Select a setting from the *Insecticide/Herbicide Application Rates* starting on page 40, as a starting point.
2. Turn the knob on the chemical meter until the display shows the appropriate number, see Figure 5-3.
3. Fill the hoppers with chemical.
4. Attach a plastic bag to each chemical diffuser.
5. Drive 1320' at a normal planting speed.
6. Weigh the contents of the bag in ounces.
7. Multiply ounces by .83 to determine the pounds per acre.
8. If required, adjust the meter setting and repeat steps 3 through 7 until the desired rate is reached.

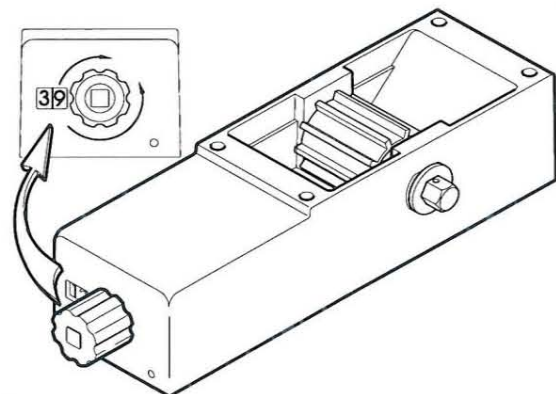

Chemical Meter with Knob
Figure 5-3

14914

Liquid Fertilizer Attachment



DANGER!

Agricultural chemicals can be dangerous if not selected and handled with care. Always read and follow directions supplied by the chemical manufacturer.

On machines equipped with the squeeze pump option, the rate of liquid fertilizer application is determined by the combination of sprockets on the squeeze pump driven and drive shafts. When changing sprocket combinations, make sure sprockets are in alignment, sprocket retaining collars are tight and chain tension is sufficiently restored.

The *Liquid Fertilizer Rates* on page 39 provide an approximate application rate only. Actual delivery will vary with temperature and the particular fertilizer being used.

IMPORTANT: Certain analysis of fertilizer if placed too close to the seed may cause germination of seedling damage especially if used in amounts in excess of fertilizer manufacturer's recommendations. Check with your fertilizer dealer or manufacturer for the correct amount and placement.

Section 5 Planting Rate Adjustments

Planting Rates for Finger Pickup Corn Meters

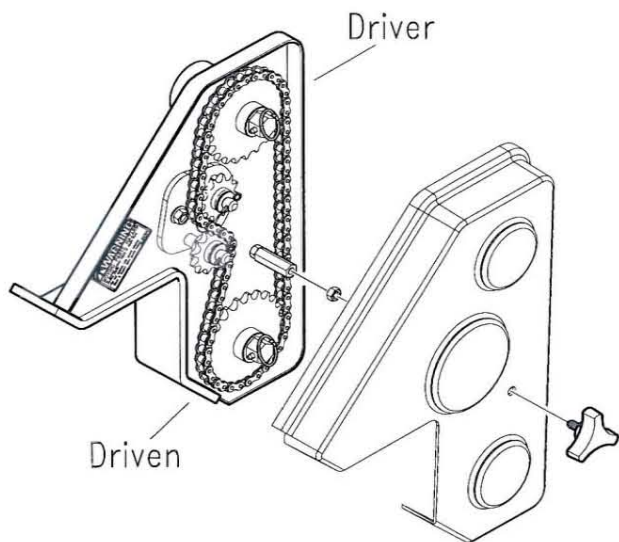

16861

Planting Rates 30" Row Width

Planting Population/ Acre	Transmission Sprockets		Recommended Speed Range (mph)	Average Seed Spacing (inches)
	Drive	Driven		
16,074	17	28	4 to 8	13.0
16,668	17	27	4 to 8	12.5
17,313	17	26	4 to 8	12.1
17,971	19	28	4 to 8	11.6
13,228	17	25	4 to 8	15.8
16,674	19	27	4 to 8	12.5
18,739	17	24	4 to 8	11.2
19,323	19	26	4 to 8	10.8
19,550	17	23	4 to 8	10.7
20,093	19	25	4 to 8	10.4
20,922	19	24	4 to 8	10.0
21,692	23	28	4 to 8	9.6
21,828	19	23	4 to 8	9.6
22,493	23	27	4 to 8	9.3
22,632	24	28	4 to 8	9.2
23,355	23	26	4 to 8	9.0
23,467	24	27	4 to 8	8.9
23,565	25	28	4 to 8	8.9

Planting Rates 30" Row Width

Planting Population/ Acre	Transmission Sprockets		Recommended Speed Range (mph)	Average Seed Spacing (inches)
	Drive	Driven		
23,630	17	19	4 to 7.5	8.8
24,286	23	25	4 to 7.5	8.6
24,367	24	26	4 to 7.5	8.6
24,435	25	27	4 to 7.5	8.6
24,504	26	28	4 to 7.5	8.5
25,288	23	24	4 to 7.5	8.3
25,338	24	25	4 to 7.5	8.3
25,372	25	26	4 to 7.5	8.2
25,409	26	27	4 to 7.5	8.2
25,444	27	28	4 to 7.5	8.2
26,383	23	23	4 to 7	7.9
27,357	28	27	4 to 7	7.6
27,394	27	26	4 to 7	7.6
27,471	25	24	4 to 7	7.6
27,525	24	23	4 to 7	7.6
28,406	28	26	4 to 6.5	7.4
28,486	27	25	4 to 6.5	7.3
28,661	25	23	4 to 6.5	7.3
29,457	19	17	4 to 6.5	7.1
29,538	28	25	4 to 6.5	7.1
29,661	27	24	4 to 6.5	7.0
29,803	26	23	4 to 6.5	7.0
30,756	28	24	3 to 6	6.8
30,945	27	23	3 to 6	6.8
31,889	23	19	3 to 5.5	6.6
32,088	28	23	3 to 5.5	6.5
33,270	24	19	3 to 5.5	6.3
34,642	25	19	3 to 5	6.0
35,604	23	17	3 to 5	5.9
36,023	26	19	3 to 5	5.8
37,146	24	17	3 to 5	5.6
37,403	27	19	3 to 5	5.6
38,678	25	17	3 to 4.5	5.4
38,784	28	19	3 to 4.5	5.4
40,219	26	17	3 to 4.5	5.2
41,761	27	17	3 to 4.5	5.0
43,303	28	17	3 to 4.5	4.8

IMPORTANT: See *Planting Rates* on page 33 for additional information. Always check seed population in the field to ensure planting rates are correct.

Section 5 Planting Rate Adjustments

Planting Rates for Brush Meters

12548

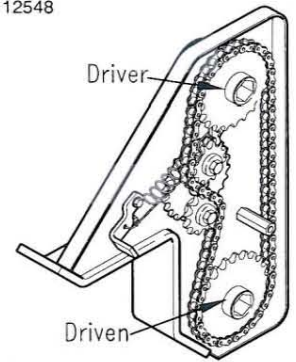

Planting Rates 30" Row Width

Transmission Sprockets		Speed Range (mph)	60 Cell Soybean or High Rate Milo/ Grain Sorghum		48 Cell Specialty Soybean or High Rate Acid-delinted Cotton		36 Cell Acid-delinted Large Cotton		30 Cell Milo/Grain Sorghum or Acid-delinted Cotton	
Drive	Driven		Planting Population/ Acre	Average Seed Spacing (inches)	Planting Population/ Acre	Average Seed Spacing (inches)	Planting Population/ Acre	Average Seed Spacing (inches)	Planting Population/ Acre	Average Seed Spacing (inches)
17	28	2 to 8	80,928	2.6	64,742	3.2	48,557	4.3	40,464	5.2
17	27	2 to 8	83,926	2.5	67,141	3.1	50,356	4.2	41,963	5.0
17	26	2 to 8	87,154	2.4	69,723	3.0	52,292	4.0	43,577	4.8
19	28	2 to 8	90,449	2.3	72,359	2.9	54,269	3.9	45,225	4.6
19	27	2 to 8	93,799	2.2	75,039	2.8	56,279	3.7	46,900	4.5
17	24	2 to 8	94,416	2.2	75,533	2.8	56,650	3.7	47,208	4.4
17	23	2 to 8	98,521	2.1	78,817	2.7	59,113	3.5	49,261	4.2
19	25	2 to 8	101,303	2.1	81,042	2.6	60,782	3.4	50,652	4.1
19	24	2 to 8	105,524	2.0	84,419	2.5	63,314	3.3	52,762	4.0
23	28	2 to 8	109,491	1.9	87,593	2.4	65,695	3.2	54,746	3.8
19	23	2 to 8	110,112	1.9	88,090	2.4	66,067	3.2	55,056	3.8
24	28	2 to 8	114,252	1.8	91,402	2.3	68,551	3.0	57,126	3.7
24	27	2 to 8	118,483	1.8	94,786	2.2	71,090	2.9	59,242	3.5
17	19	2 to 8	119,263	1.8	95,410	2.2	71,558	2.9	59,631	3.5
24	26	2 to 8	123,040	1.7	98,432	2.1	73,824	2.8	61,520	3.4
26	28	2 to 8	123,773	1.7	99,018	2.1	74,264	2.8	61,886	3.4
24	25	2 to 8	127,962	1.6	102,370	2.0	76,772	2.7	63,981	3.3
26	27	2 to 8	128,357	1.6	102,686	2.0	77,014	2.7	64,178	3.3
23	23	2 to 8	133,294	1.6	106,635	2.0	79,976	2.6	66,647	3.1
27	26	2 to 8	138,420	1.5	110,736	1.9	83,052	2.5	69,210	3.0
24	23	2 to 8	139,089	1.5	111,271	1.9	83,453	2.5	69,544	3.0
25	23	2 to 8	144,884	1.4	115,907	1.8	86,930	2.4	72,442	2.9
19	17	2 to 8	148,975	1.4	119,180	1.8	89,385	2.3	74,488	2.8
27	24	2 to 8	149,955	1.4	119,964	1.7	89,973	2.3	74,978	2.8
28	24	2 to 8	155,509	1.3	124,407	1.7	93,305	2.2	77,755	2.7
23	19	2 to 8	161,355	1.3	129,084	1.6	96,813	2.2	80,678	2.6
28	23	2 to 8	162,270	1.3	129,816	1.6	97,362	2.1	81,135	2.6
24	19	2 to 8	168,371	1.2	134,696	1.6	101,023	2.1	84,185	2.5
25	19	2 to 8	175,386	1.2	140,309	1.5	105,232	2.0	87,693	2.4
23	17	2 to 8	180,338	1.2	144,270	1.5	108,233	1.9	90,169	2.3
26	19	2 to 7	182,402	1.1	145,922	1.4	109,441	1.9	91,201	2.3
27	19	2 to 7	189,417	1.1	151,534	1.4	113,650	1.8	94,709	2.2
28	19	2 to 7	196,433	1.1	157,146	1.3	117,860	1.8	98,216	2.1
26	17	2 to 7	203,861	1.0	163,089	1.3	122,317	1.7	101,930	2.1
27	17	2 to 7	211,702	0.9	169,362	1.2	127,021	1.6	105,851	2.0
28	17	2 to 7	219,542	0.9	175,634	1.2	131,725	1.6	109,771	1.9

IMPORTANT: See *Planting Rates* on page 33 for additional information. Always check seed population in the field to ensure planting rates are correct.

Section 5 Planting Rate Adjustments

Planting Rates for Brush Meters (continued)

Meters equipped with the 12 cell acid-delinted hill-drop cotton discs will plant from 3 to 6 seeds per cell because of variations in cotton seed size.

Determine which hill spacing is desired and select the transmission ratio that is closest to that hill spacing on the chart.

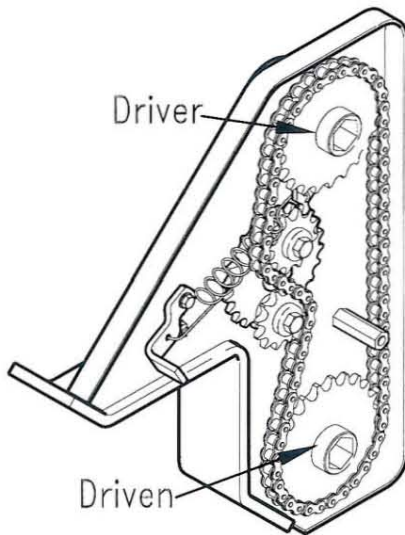

12548

Planting Rates 30" Row Width

Transmission Sprockets		Speed Range (mph)	12 Cell Hill-drop Cotton, Acid-delinted	
Drive	Driven		Hills/Acre	Average Hill Spacing (inches)
17	28	2 to 8	16,186	12.9
17	27	2 to 8	16,785	12.5
17	26	2 to 8	17,431	12.0
19	28	2 to 8	18,090	11.6
19	27	2 to 8	18,760	11.1
17	24	2 to 8	18,883	11.1
17	23	2 to 8	19,704	10.6
19	25	2 to 8	20,261	10.3
19	24	2 to 8	21,105	9.9
23	28	2 to 8	21,898	9.5
19	23	2 to 8	22,022	9.5
24	28	2 to 8	22,850	9.2

To determine the average seeds per hill and hills per acre do the following field check:

1. Measure 1/1000 of an acre. (1/1000 acre = length of row 17'5" for 30" widths).
2. Multiply the average seed per hill by hills per acre.

Example:

$$4 \text{ seeds per hill} \times (13 \text{ hills} \times 1000) = 52,000$$

Planting Rates 30" Row Width

Transmission Sprockets		Speed Range (mph)	12 Cell Hill-drop Cotton, Acid-delinted	
Drive	Driven		Hills/Acre	Average Hill Spacing (inches)
24	27	2 to 8	23,697	8.8
17	19	2 to 8	23,853	8.8
24	26	2 to 8	24,608	8.5
26	28	2 to 8	24,755	8.4
24	25	2 to 8	25,592	8.2
26	27	2 to 8	25,671	8.1
23	23	2 to 8	26,659	7.8
27	26	2 to 8	27,684	7.6
24	23	2 to 8	27,818	7.5
25	23	2 to 8	28,977	7.2
19	17	2 to 8	29,795	7.0
27	24	2 to 8	29,991	7.0
28	24	2 to 8	31,102	6.7
23	19	2 to 8	32,271	6.5
28	23	2 to 8	32,454	6.5
24	19	2 to 8	33,674	6.2
25	19	2 to 8	35,077	6.0
23	17	2 to 8	36,068	5.8
26	19	2 to 7	36,480	5.7
27	19	2 to 7	37,883	5.5
28	19	2 to 7	39,287	5.3
26	17	2 to 7	40,772	5.1
27	17	2 to 7	42,340	4.9
28	17	2 to 7	43,908	4.8

IMPORTANT: See *Planting Rates* on page 33 for additional information. Always check seed population in the field to ensure planting rates are correct.

Liquid Fertilizer Rates

Liquid Fertilizer Rate Chart

Transmission Combination		Hose Dia. at 5/16	Hose Dia. at 1/2
Driver	Driven	Gallons/Acre	Gallons/Acre
15	44	3.49	8.99
15	41	3.75	9.65
17	44	4.06	10.19
17	41	4.25	10.94
19	44	4.43	11.39
15	32	4.8	12.36
21	41	5.25	13.51
17	32	5.45	14.01
24	41	6.00	15.44
19	32	6.09	15.66
15	24	6.41	16.48
17	24	7.26	18.68
15	21	7.32	18.84
17	23	7.58	19.49
15	19	8.09	20.82
17	21	8.30	21.35
19	23	8.47	21.79
15	17	9.04	23.27
17	19	9.17	23.60
23	24	9.82	25.28
24	23	10.70	27.52
19	17	11.46	29.48
17	15	11.62	29.89
23	19	12.41	31.93
21	17	12.66	32.58
19	15	12.98	33.41
23	17	13.87	35.68
21	15	14.35	36.93
24	17	14.47	37.24
32	21	15.62	40.19
24	15	16.40	42.20
32	19	17.26	44.42
41	24	17.51	45.06

NOTE: The delivery rates are approximate and will vary with changes in temperature and the specific fertilizer being used.

Section 5 Planting Rate Adjustments

Insecticide/Herbicide Application Rates

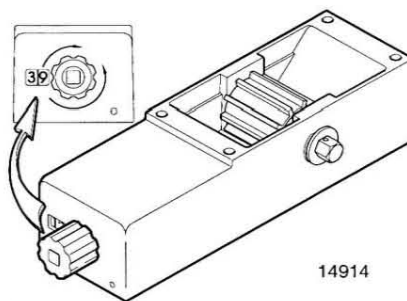

Clay Granules Herbicide Rate Chart

Approximate Rate in Lbs/Acre

Meter Setting	30 Inch Rows miles per hour			36 Inch Rows miles per hour			38 Inch Rows miles per hour			Ounces per 1000 Row Ft. miles per hour		
	4	6	8	4	6	8	4	6	8	4	6	8
10	0.9	0.6	0.5	1.1	0.8	0.6	1.2	0.8	0.6	0.87	0.58	0.43
11	1.1	0.7	0.6	1.3	0.9	0.7	1.4	0.9	0.7	1.03	0.69	0.51
12	1.3	0.9	0.7	1.6	1.1	0.8	1.7	1.1	0.8	1.22	0.82	0.61
13	1.6	1.1	0.8	1.9	1.3	0.9	2.0	1.3	1.0	1.45	0.97	0.72
14	1.9	1.2	0.9	2.2	1.5	1.1	2.3	1.6	1.2	1.70	1.13	0.85
15	2.1	1.4	1.1	2.6	1.7	1.3	2.7	1.8	1.4	1.97	1.32	0.99
16	2.5	1.6	1.2	3.0	2.0	1.5	3.1	2.1	1.6	2.27	1.51	1.14
17	2.8	1.9	1.4	3.4	2.3	1.7	3.6	2.4	1.8	2.59	1.72	1.29
18	3.2	2.1	1.6	3.8	2.5	1.9	4.0	2.7	2.0	2.92	1.94	1.46
19	3.6	2.4	1.8	4.3	2.8	2.1	4.5	3.0	2.2	3.26	2.17	1.63
20	3.9	2.6	2.0	4.7	3.2	2.4	5.0	3.3	2.5	3.62	2.41	1.81
21	4.3	2.9	2.2	5.2	3.5	2.6	5.5	3.7	2.7	3.99	2.66	1.99
22	4.8	3.2	2.4	5.7	3.8	2.9	6.0	4.0	3.0	4.37	2.91	2.18
23	5.2	3.4	2.6	6.2	4.1	3.1	6.5	4.4	3.3	4.75	3.17	2.37
24	5.6	3.7	2.8	6.7	4.5	3.4	7.1	4.7	3.5	5.14	3.43	2.57
25	6.0	4.0	3.0	7.2	4.8	3.6	7.6	5.1	3.8	5.53	3.69	2.77
26	6.5	4.3	3.2	7.7	5.2	3.9	8.2	5.4	4.1	5.93	3.95	2.96
27	6.9	4.6	3.4	8.3	5.5	4.1	8.7	5.8	4.4	6.33	4.22	3.16
28	7.3	4.9	3.7	8.8	5.9	4.4	9.3	6.2	4.6	6.72	4.48	3.36
29	7.8	5.2	3.9	9.3	6.2	4.7	9.8	6.5	4.9	7.12	4.75	3.56
30	8.2	5.5	4.1	9.8	6.6	4.9	10.4	6.9	5.2	7.52	5.01	3.76
31	8.6	5.7	4.3	10.3	6.9	5.2	10.9	7.3	5.5	7.92	5.28	3.96
32	9.1	6.0	4.5	10.9	7.2	5.4	11.5	7.6	5.7	8.31	5.54	4.16
33	9.5	6.3	4.7	11.4	7.6	5.7	12.0	8.0	6.0	8.71	5.80	4.35
34	9.9	6.6	5.0	11.9	7.9	5.9	12.5	8.4	6.3	9.10	6.06	4.55
35	10.3	6.9	5.2	12.4	8.3	6.2	13.1	8.7	6.5	9.48	6.32	4.74
36	10.7	7.2	5.4	12.9	8.6	6.4	13.6	9.1	6.8	9.87	6.58	4.93
37	11.2	7.4	5.6	13.4	8.9	6.7	14.1	9.4	7.1	10.25	6.83	5.12
38	11.6	7.7	5.8	13.9	9.3	6.9	14.6	9.8	7.3	10.62	7.08	5.31
39	12.0	8.0	6.0	14.4	9.6	7.2	15.2	10.1	7.6	11.00	7.33	5.50
40	12.4	8.3	6.2	14.9	9.9	7.4	15.7	10.5	7.8	11.37	7.58	5.69
41	12.8	8.5	6.4	15.3	10.2	7.7	16.2	10.8	8.1	11.74	7.83	5.87
42	13.2	8.8	6.6	15.8	10.5	7.9	16.7	11.1	8.3	12.11	8.07	6.05
43	13.6	9.1	6.8	16.3	10.9	8.2	17.2	11.5	8.6	12.47	8.32	6.24
44	14.0	9.3	7.0	16.8	11.2	8.4	17.7	11.8	8.8	12.84	8.56	6.42
45	14.4	9.6	7.2	17.2	11.5	8.6	18.2	12.1	9.1	13.20	8.80	6.60
46	14.8	9.8	7.4	17.7	11.8	8.9	18.7	12.5	9.3	13.56	9.04	6.78
47	15.2	10.1	7.6	18.2	12.1	9.1	19.2	12.8	9.6	13.92	9.28	6.96
48	15.6	10.4	7.8	18.7	12.4	9.3	19.7	13.1	9.8	14.28	9.52	7.14
49	16.0	10.6	8.0	19.1	12.8	9.6	20.2	13.5	10.1	14.65	9.76	7.32
50	16.3	10.9	8.2	19.6	13.1	9.8	20.7	13.8	10.3	15.01	10.01	7.51
51	16.7	11.2	8.4	20.1	13.4	10.0	21.2	14.1	10.6	15.38	10.25	7.69
52	17.2	11.4	8.6	20.6	13.7	10.3	21.7	14.5	10.9	15.75	10.50	7.87
53	17.6	11.7	8.8	21.1	14.0	10.5	22.2	14.8	11.1	16.12	10.75	8.06
54	18.0	12.0	9.0	21.6	14.4	10.8	22.8	15.2	11.4	16.50	11.00	8.25
55	18.4	12.3	9.2	22.1	14.7	11.0	23.3	15.5	11.6	16.88	11.26	8.44

Section 5 Planting Rate Adjustments

Clay Granules Herbicide Rate Chart (con't.)

Approximate Rate in Lbs/Acre

Meter Setting	30 Inch Rows miles per hour			36 Inch Rows miles per hour			38 Inch Rows miles per hour			Ounces per 1000 Row Ft. miles per hour		
	4	6	8	4	6	8	4	6	8	4	6	8
	56	18.8	12.5	9.4	22.6	15.0	11.3	23.8	15.9	11.9	17.27	11.52
57	19.2	12.8	9.6	23.1	15.4	11.5	24.4	16.2	12.2	17.67	11.78	8.83
58	19.7	13.1	9.8	23.6	15.7	11.8	24.9	16.6	12.5	18.07	12.05	9.04
59	20.1	13.4	10.1	24.2	16.1	12.1	25.5	17.0	12.7	18.48	12.32	9.24
60	20.6	13.7	10.3	24.7	16.5	12.4	26.1	17.4	13.0	18.90	12.60	9.45
61	21.1	14.0	10.5	25.3	16.8	12.6	26.7	17.8	13.3	19.33	12.89	9.67
62	21.5	14.4	10.8	25.8	17.2	12.9	27.3	18.2	13.6	19.77	13.18	9.89
63	22.0	14.7	11.0	26.4	17.6	13.2	27.9	18.6	13.9	20.22	13.48	10.11
64	22.5	15.0	11.3	27.0	18.0	13.5	28.5	19.0	14.3	20.68	13.79	10.34
65	23.0	15.4	11.5	27.6	18.4	13.8	29.2	19.4	14.6	21.16	14.10	10.58
66	23.6	15.7	11.8	28.3	18.9	14.1	29.8	19.9	14.9	21.64	14.43	10.82
67	24.1	16.1	12.1	28.9	19.3	14.5	30.5	20.3	15.3	22.14	14.76	11.07
68	24.7	16.4	12.3	29.6	19.7	14.8	31.2	20.8	15.6	22.65	15.10	11.33
69	25.2	16.8	12.6	30.3	20.2	15.1	32.0	21.3	16.0	23.18	15.45	11.59
70	25.8	17.2	12.9	31.0	20.7	15.5	32.7	21.8	16.3	23.72	15.81	11.86
71	26.4	17.6	13.2	31.7	21.1	15.9	33.5	22.3	16.7	24.27	16.18	12.13
72	27.0	18.0	13.5	32.5	21.6	16.2	34.2	22.8	17.1	24.84	16.56	12.42
73	27.7	18.5	13.8	33.2	22.1	16.6	35.0	23.4	17.5	25.42	16.95	12.71
74	28.3	18.9	14.2	34.0	22.7	17.0	35.9	23.9	17.9	26.02	17.34	13.01
75	29.0	19.3	14.5	34.8	23.2	17.4	36.7	24.5	18.4	26.63	17.75	13.31
76	29.7	19.8	14.8	35.6	23.7	17.8	37.6	25.1	18.8	27.25	18.17	13.63
77	30.4	20.3	15.2	36.5	24.3	18.2	38.5	25.6	19.2	27.90	18.60	13.95
78	31.1	20.7	15.5	37.3	24.9	18.7	39.4	26.2	19.7	28.55	19.03	14.28
79	31.8	21.2	15.9	38.2	25.5	19.1	40.3	26.9	20.1	29.22	19.48	14.61
80	32.6	21.7	16.3	39.1	26.1	19.5	41.2	27.5	20.6	29.90	19.94	14.95
81	33.3	22.2	16.7	40.0	26.7	20.0	42.2	28.1	21.1	30.60	20.40	15.30
82	34.1	22.7	17.0	40.9	27.3	20.5	43.2	28.8	21.6	31.31	20.87	15.65
83	34.9	23.3	17.4	41.9	27.9	20.9	44.2	29.4	22.1	32.03	21.35	16.01
84	35.7	23.8	17.8	42.8	28.5	21.4	45.2	30.1	22.6	32.76	21.84	16.38
85	36.5	24.3	18.2	43.8	29.2	21.9	46.2	30.8	23.1	33.50	22.33	16.75
86	37.3	24.9	18.6	44.8	29.8	22.4	47.2	31.5	23.6	34.25	22.83	17.12
87	38.1	25.4	19.1	45.7	30.5	22.9	48.3	32.2	24.1	35.00	23.33	17.50
88	38.9	26.0	19.5	46.7	31.2	23.4	49.3	32.9	24.7	35.76	23.84	17.88
89	39.8	26.5	19.9	47.7	31.8	23.9	50.4	33.6	25.2	36.53	24.35	18.27
90	40.6	27.1	20.3	48.7	32.5	24.4	51.4	34.3	25.7	37.30	24.87	18.65

Section 5 Planting Rate Adjustments

Insecticide/Herbicide Application Rates

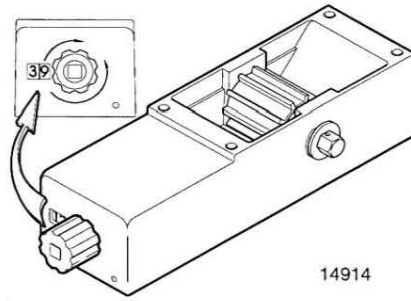

14914

Clay Granules Insecticide Rate Chart

Approximate Rate in Lbs/Acre

Meter Setting	30 Inch Rows miles per hour			36 Inch Rows miles per hour			38 Inch Rows miles per hour			Ounces per 1000 Row Ft. miles per hour		
	4	6	8	4	6	8	4	6	8	4	6	8
10	0.9	0.6	0.5	1.1	0.7	0.6	1.2	0.8	0.6	0.85	0.57	0.42
11	1.0	0.7	0.5	1.2	0.8	0.6	1.3	0.8	0.6	0.92	0.61	0.46
12	1.2	0.8	0.6	1.4	0.9	0.7	1.5	1.0	0.7	1.06	0.71	0.53
13	1.4	0.9	0.7	1.6	1.1	0.8	1.7	1.2	0.9	1.25	0.84	0.63
14	1.6	1.1	0.8	2.0	1.3	1.0	2.1	1.4	1.0	1.50	1.00	0.75
15	2.0	1.3	1.0	2.3	1.6	1.2	2.5	1.6	1.2	1.79	1.19	0.90
16	2.3	1.5	1.2	2.8	1.8	1.4	2.9	2.0	1.5	2.12	1.42	1.06
17	2.7	1.8	1.4	3.3	2.2	1.6	3.4	2.3	1.7	2.49	1.66	1.24
18	3.1	2.1	1.6	3.8	2.5	1.9	4.0	2.7	2.0	2.88	1.92	1.44
19	3.6	2.4	1.8	4.3	2.9	2.2	4.6	3.0	2.3	3.31	2.20	1.65
20	4.1	2.7	2.0	4.9	3.3	2.4	5.2	3.4	2.6	3.75	2.50	1.87
21	4.6	3.1	2.3	5.5	3.7	2.7	5.8	3.9	2.9	4.20	2.80	2.10
22	5.1	3.4	2.5	6.1	4.1	3.1	6.4	4.3	3.2	4.68	3.12	2.34
23	5.6	3.7	2.8	6.7	4.5	3.4	7.1	4.7	3.6	5.16	3.44	2.58
24	6.1	4.1	3.1	7.4	4.9	3.7	7.8	5.2	3.9	5.64	3.76	2.82
25	6.7	4.5	3.3	8.0	5.3	4.0	8.5	5.6	4.2	6.14	4.09	3.07
26	7.2	4.8	3.6	8.7	5.8	4.3	9.1	6.1	4.6	6.63	4.42	3.31
27	7.8	5.2	3.9	9.3	6.2	4.7	9.8	6.5	4.9	7.12	4.75	3.56
28	8.3	5.5	4.1	9.9	6.6	5.0	10.5	7.0	5.2	7.61	5.07	3.81
29	8.8	5.9	4.4	10.6	7.1	5.3	11.2	7.4	5.6	8.10	5.40	4.05
30	9.3	6.2	4.7	11.2	7.5	5.6	11.8	7.9	5.9	8.58	5.72	4.29
31	9.9	6.6	4.9	11.8	7.9	5.9	12.5	8.3	6.2	9.05	6.03	4.52
32	10.4	6.9	5.2	12.4	8.3	6.2	13.1	8.7	6.6	9.51	6.34	4.76
33	10.9	7.2	5.4	13.0	8.7	6.5	13.7	9.2	6.9	9.97	6.65	4.98
34	11.3	7.6	5.7	13.6	9.1	6.8	14.4	9.6	7.2	10.41	6.94	5.21
35	11.8	7.9	5.9	14.2	9.5	7.1	15.0	10.0	7.5	10.85	7.23	5.42
36	12.3	8.2	6.1	14.7	9.8	7.4	15.5	10.4	7.8	11.27	7.52	5.64
37	12.7	8.5	6.4	15.3	10.2	7.6	16.1	10.7	8.1	11.69	7.79	5.84
38	13.2	8.8	6.6	15.8	10.5	7.9	16.7	11.1	8.3	12.09	8.06	6.05
39	13.6	9.1	6.8	16.3	10.9	8.2	17.2	11.5	8.6	12.48	8.32	6.24
40	14.0	9.3	7.0	16.8	11.2	8.4	17.7	11.8	8.9	12.87	8.58	6.43
41	14.4	9.6	7.2	17.3	11.5	8.7	18.3	12.2	9.1	13.24	8.83	6.62
42	14.8	9.9	7.4	17.8	11.9	8.9	18.8	12.5	9.4	13.60	9.07	6.80
43	15.2	10.1	7.6	18.2	12.2	9.1	19.2	12.8	9.6	13.96	9.31	6.98
44	15.6	10.4	7.8	18.7	12.5	9.3	19.7	13.2	9.9	14.31	9.54	7.15
45	16.0	10.6	8.0	19.1	12.8	9.6	20.2	13.5	10.1	14.65	9.77	7.33
46	16.3	10.9	8.2	19.6	13.1	9.8	20.7	13.8	10.3	14.99	9.99	7.49
47	16.7	11.1	8.3	20.0	13.3	10.0	21.1	14.1	10.6	15.32	10.21	7.66
48	17.0	11.4	8.5	20.5	13.6	10.2	21.6	14.4	10.8	15.65	10.43	7.82
49	17.4	11.6	8.7	20.9	13.9	10.4	22.0	14.7	11.0	15.98	10.65	7.99
50	17.8	11.8	8.9	21.3	14.2	10.7	22.5	15.0	11.2	16.30	10.87	8.15
51	18.1	12.1	9.1	21.7	14.5	10.9	22.9	15.3	11.5	16.63	11.08	8.31
52	18.5	12.3	9.2	22.2	14.8	11.1	23.4	15.6	11.7	16.95	11.30	8.48
53	18.8	12.5	9.4	22.6	15.1	11.3	23.8	15.9	11.9	17.29	11.52	8.64
54	19.2	12.8	9.6	23.0	15.4	11.5	24.3	16.2	12.1	17.62	11.75	8.81
55	19.6	13.0	9.8	23.5	15.6	11.7	24.8	16.5	12.4	17.96	11.97	8.98

Section 5 Planting Rate Adjustments

Clay Granules Insecticide Rate Chart (con't.)

Approximate Rate in Lbs/Acre

Meter Setting	30 Inch Rows miles per hour			36 Inch Rows miles per hour			38 Inch Rows miles per hour			Ounces per 1000 Row Ft. miles per hour		
	4	6	8	4	6	8	4	6	8	4	6	8
56	19.9	13.3	10.0	23.9	15.9	12.0	25.2	16.8	12.6	18.31	12.21	9.15
57	20.3	13.5	10.2	24.4	16.3	12.2	25.7	17.2	12.9	18.66	12.44	9.33
58	20.7	13.8	10.4	24.9	16.6	12.4	26.2	17.5	13.1	19.03	12.69	9.51
59	21.1	14.1	10.6	25.4	16.9	12.7	26.8	17.8	13.4	19.40	12.94	9.70
60	21.6	14.4	10.8	25.9	17.2	12.9	27.3	18.2	13.6	19.79	13.19	9.90
61	22.0	14.7	11.0	26.4	17.6	13.2	27.8	18.6	13.9	20.19	13.46	10.10
62	22.4	15.0	11.2	26.9	18.0	13.5	28.4	18.9	14.2	20.61	13.74	10.30
63	22.9	15.3	11.5	27.5	18.3	13.7	29.0	19.3	14.5	21.04	14.02	10.52
64	23.4	15.6	11.7	28.1	18.7	14.0	29.6	19.7	14.8	21.48	14.32	10.74
65	23.9	15.9	11.9	28.7	19.1	14.3	30.3	20.2	15.1	21.94	14.63	10.97
66	24.4	16.3	12.2	29.3	19.5	14.7	30.9	20.6	15.5	22.42	14.95	11.21
67	25.0	16.6	12.5	30.0	20.0	15.0	31.6	21.1	15.8	22.92	15.28	11.46
68	25.5	17.0	12.8	30.6	20.4	15.3	32.3	21.5	16.2	23.44	15.62	11.72
69	26.1	17.4	13.1	31.3	20.9	15.7	33.0	22.0	16.5	23.97	15.98	11.99
70	26.7	17.8	13.4	32.0	21.4	16.0	33.8	22.5	16.9	24.52	16.35	12.26
71	27.3	18.2	13.7	32.8	21.9	16.4	34.6	23.1	17.3	25.10	16.73	12.55
72	28.0	18.7	14.0	33.6	22.4	16.8	35.4	23.6	17.7	25.69	17.13	12.84
73	28.6	19.1	14.3	34.4	22.9	17.2	36.3	24.2	18.1	26.30	17.53	13.15
74	29.3	19.6	14.7	35.2	23.5	17.6	37.1	24.8	18.6	26.93	17.95	13.46
75	30.0	20.0	15.0	36.0	24.0	18.0	38.0	25.3	19.0	27.58	18.38	13.79
76	30.8	20.5	15.4	36.9	24.6	18.5	38.9	26.0	19.5	28.24	18.83	14.12
77	31.5	21.0	15.7	37.8	25.2	18.9	39.9	26.6	19.9	28.92	19.28	14.46
78	32.2	21.5	16.1	38.7	25.8	19.3	40.8	27.2	20.4	29.61	19.74	14.81
79	33.0	22.0	16.5	39.6	26.4	19.8	41.8	27.9	20.9	30.32	20.21	15.16
80	33.8	22.5	16.9	40.6	27.0	20.3	42.8	28.5	21.4	31.03	20.69	15.52
81	34.6	23.1	17.3	41.5	27.7	20.8	43.8	29.2	21.9	31.76	21.17	15.88
82	35.4	23.6	17.7	42.5	28.3	21.2	44.8	29.9	22.4	32.49	21.66	16.25
83	36.2	24.1	18.1	43.4	29.0	21.7	45.8	30.5	22.9	33.23	22.15	16.62
84	37.0	24.7	18.5	44.4	29.6	22.2	46.8	31.2	23.4	33.97	22.65	16.99
85	37.8	25.2	18.9	45.4	30.2	22.7	47.9	31.9	23.9	34.71	23.14	17.35
86	38.6	25.7	19.3	46.3	30.9	23.2	48.9	32.6	24.4	35.44	23.63	17.72
87	39.4	26.3	19.7	47.3	31.5	23.6	49.9	33.2	24.9	36.17	24.11	18.08
88	40.2	26.8	20.1	48.2	32.1	24.1	50.8	33.9	25.4	36.88	24.59	18.44
89	40.9	27.3	20.5	49.1	32.7	24.6	51.8	34.5	25.9	37.58	25.05	18.79
90	41.7	27.8	20.8	50.0	33.3	25.0	52.7	35.2	26.4	38.25	25.50	19.13

Section 5 Planting Rate Adjustments

Insecticide/Herbicide Application Rates

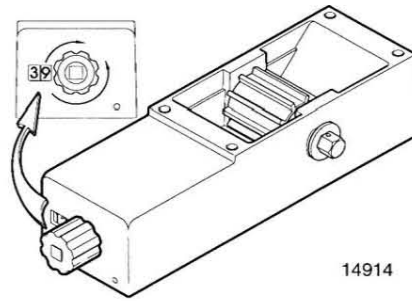

14914

Sand Granules Chemical Rate Chart

Approximate Rate in Lbs/Acre

Meter Setting	30 Inch Rows miles per hour			36 Inch Rows miles per hour			38 Inch Rows miles per hour			Ounces per 1000 Row Ft. miles per hour		
	4	6	8	4	6	8	4	6	8	4	6	8
5	1.7	1.1	0.8	2.0	1.3	1.0	2.1	1.4	1.1	1.53	1.02	0.76
6	2.2	1.4	1.1	2.6	1.7	1.3	2.7	1.8	1.4	1.98	1.32	0.99
7	2.7	1.8	1.3	3.2	2.2	1.6	3.4	2.3	1.7	2.47	1.65	1.23
8	3.3	2.2	1.6	3.9	2.6	2.0	4.1	2.8	2.1	3.00	2.00	1.50
9	3.9	2.6	1.9	4.7	3.1	2.3	4.9	3.3	2.5	3.56	2.38	1.78
10	4.5	3.0	2.3	5.4	3.6	2.7	5.7	3.8	2.9	4.17	2.78	2.08
11	5.2	3.5	2.6	6.3	4.2	3.1	6.6	4.4	3.3	4.82	3.21	2.41
12	6.0	4.0	3.0	7.2	4.8	3.6	7.6	5.1	3.8	5.50	3.67	2.75
13	6.8	4.5	3.4	8.1	5.4	4.1	8.6	5.7	4.3	6.23	4.15	3.12
14	7.6	5.1	3.8	9.1	6.1	4.6	9.6	6.4	4.8	7.00	4.66	3.50
15	8.5	5.7	4.2	10.2	6.8	5.1	10.8	7.2	5.4	7.80	5.20	3.90
16	9.4	6.3	4.7	11.3	7.5	5.7	11.9	7.9	6.0	8.65	5.77	4.32
17	10.4	6.9	5.2	12.5	8.3	6.2	13.1	8.8	6.6	9.53	6.35	4.77
18	11.4	7.6	5.7	13.7	9.1	6.8	14.4	9.6	7.2	10.45	6.97	5.23
19	12.4	8.3	6.2	14.9	9.9	7.5	15.7	10.5	7.9	11.41	7.60	5.70
20	13.5	9.0	6.7	16.2	10.8	8.1	17.1	11.4	8.5	12.39	8.26	6.20
21	14.6	9.7	7.3	17.5	11.7	8.8	18.5	12.3	9.2	13.41	8.94	6.71
22	15.8	10.5	7.9	18.9	12.6	9.5	19.9	13.3	10.0	14.47	9.64	7.23
23	16.9	11.3	8.5	20.3	13.5	10.2	21.4	14.3	10.7	15.55	10.36	7.77
24	18.1	12.1	9.1	21.8	14.5	10.9	23.0	15.3	11.5	16.65	11.10	8.33
25	19.4	12.9	9.7	23.2	15.5	11.6	24.5	16.3	12.3	17.78	11.86	8.89
26	20.6	13.7	10.3	24.7	16.5	12.4	26.1	17.4	13.1	18.94	12.62	9.47
27	21.9	14.6	11.0	26.3	17.5	13.1	27.7	18.5	13.9	20.11	13.41	10.06
28	23.2	15.5	11.6	27.8	18.6	13.9	29.4	19.6	14.7	21.30	14.20	10.65
29	24.5	16.3	12.3	29.4	19.6	14.7	31.0	20.7	15.5	22.51	15.01	11.26
30	25.8	17.2	12.9	31.0	20.7	15.5	32.7	21.8	16.4	23.73	15.82	11.87
31	27.2	18.1	13.6	32.6	21.7	16.3	34.4	22.9	17.2	24.97	16.64	12.48
32	28.5	19.0	14.3	34.2	22.8	17.1	36.1	24.1	18.1	26.21	17.47	13.10
33	29.9	19.9	14.9	35.9	23.9	17.9	37.8	25.2	18.9	27.45	18.30	13.73
34	31.3	20.8	15.6	37.5	25.0	18.8	39.6	26.4	19.8	28.71	19.14	14.35
35	32.6	21.8	16.3	39.2	26.1	19.6	41.3	27.5	20.7	29.96	19.97	14.98
36	34.0	22.7	17.0	40.8	27.2	20.4	43.0	28.7	21.5	31.21	20.81	15.61
37	35.4	23.6	17.7	42.4	28.3	21.2	44.8	29.8	22.4	32.46	21.64	16.23
38	36.7	24.5	18.4	44.0	29.4	22.0	46.5	31.0	23.2	33.71	22.47	16.85
39	38.1	25.4	19.0	45.7	30.4	22.8	48.2	32.1	24.1	34.95	23.30	17.47
40	39.4	26.3	19.7	47.3	31.5	23.6	49.9	33.2	24.9	36.17	24.12	18.09
41	40.7	27.1	20.4	48.9	32.6	24.4	51.6	34.4	25.8	37.39	24.93	18.70
42	42.0	28.0	21.0	50.4	33.6	25.2	53.2	35.5	26.6	38.60	25.73	19.30
43	43.3	28.9	21.7	52.0	34.7	26.0	54.9	36.6	27.4	39.79	26.53	19.90
44	44.6	29.7	22.3	53.5	35.7	26.8	56.5	37.7	28.2	40.97	27.31	20.48
45	45.9	30.6	22.9	55.1	36.7	27.5	58.1	38.7	29.0	42.13	28.08	21.06
46	47.1	31.4	23.6	56.5	37.7	28.3	59.7	39.8	29.8	43.27	28.85	21.63
47	48.3	32.2	24.2	58.0	38.7	29.0	61.2	40.8	30.6	44.39	29.59	22.20
48	49.5	33.0	24.8	59.5	39.6	29.7	62.7	41.8	31.4	45.49	30.33	22.75
49	50.7	33.8	25.4	60.9	40.6	30.4	64.2	42.8	32.1	46.58	31.05	23.29
50	51.9	34.6	25.9	62.3	41.5	31.1	65.7	43.8	32.8	47.64	31.76	23.82

Section 5 Planting Rate Adjustments

Sand Granules Chemical Rate Chart (con't.)

Approximate Rate in Lbs/Acre

Meter Setting	30 Inch Rows miles per hour			36 Inch Rows miles per hour			38 Inch Rows miles per hour			Ounces per 1000 Row Ft. miles per hour		
	4	6	8	4	6	8	4	6	8	4	6	8
	51	53.0	35.3	26.5	63.6	42.4	31.8	67.1	44.7	33.6	48.68	32.45
52	54.1	36.1	27.1	64.9	43.3	32.5	68.5	45.7	34.3	49.70	33.13	24.85
53	55.2	36.8	27.6	66.2	44.2	33.1	69.9	46.6	34.9	50.70	33.80	25.35
54	56.3	37.5	28.1	67.5	45.0	33.8	71.2	47.5	35.6	51.68	34.45	25.84
55	57.3	38.2	28.7	68.8	45.9	34.4	72.6	48.4	36.3	52.64	35.09	26.32
56	58.3	38.9	29.2	70.0	46.7	35.0	73.9	49.2	36.9	53.58	35.72	26.79
57	59.4	39.6	29.7	71.2	47.5	35.6	75.1	50.1	37.6	54.50	36.34	27.25
58	60.3	40.2	30.2	72.4	48.3	36.2	76.4	50.9	38.2	55.42	36.94	27.71
59	61.3	40.9	30.7	73.6	49.1	36.8	77.6	51.8	38.8	56.32	37.54	28.16
60	62.3	41.5	31.1	74.8	49.8	37.4	78.9	52.6	39.4	57.21	38.14	28.60
61	63.3	42.2	31.6	75.9	50.6	38.0	80.1	53.4	40.0	58.09	38.73	29.05
62	64.2	42.8	32.1	77.1	51.4	38.5	81.3	54.2	40.6	58.97	39.31	29.48
63	65.2	43.5	32.6	78.2	52.1	39.1	82.5	55.0	41.3	59.85	39.90	29.92
64	66.1	44.1	33.1	79.4	52.9	39.7	83.7	55.8	41.9	60.73	40.49	30.37
65	67.1	44.7	33.6	80.5	53.7	40.3	85.0	56.6	42.5	61.62	41.08	30.81
66	68.1	45.4	34.0	81.7	54.5	40.9	86.2	57.5	43.1	62.53	41.69	31.26
67	69.1	46.1	34.5	82.9	55.3	41.5	87.5	58.3	43.7	63.45	42.30	31.73
68	70.1	46.8	35.1	84.2	56.1	42.1	88.8	59.2	44.4	64.40	42.93	32.20
69	71.2	47.5	35.6	85.4	57.0	42.7	90.1	60.1	45.1	65.38	43.58	32.69
70	72.3	48.2	36.2	86.8	57.8	43.4	91.5	61.0	45.8	66.39	44.26	33.20
71	73.5	49.0	36.7	88.1	58.8	44.1	93.0	62.0	46.5	67.45	44.97	33.72
72	74.7	49.8	37.3	89.6	59.7	44.8	94.5	63.0	47.3	68.56	45.71	34.28
73	75.9	50.6	38.0	91.1	60.7	45.6	96.1	64.1	48.1	69.73	46.49	34.86
74	77.3	51.5	38.6	92.7	61.8	46.4	97.8	65.2	48.9	70.96	47.31	35.48
75	78.7	52.5	39.4	94.5	63.0	47.2	99.6	66.4	49.8	72.28	48.19	36.14
76	80.2	53.5	40.1	96.3	64.2	48.1	101.6	67.7	50.8	73.68	49.12	36.84
77	81.9	54.6	40.9	98.2	65.5	49.1	103.6	69.1	51.8	75.18	50.12	37.59
78	83.6	55.7	41.8	100.3	66.9	50.2	105.9	70.6	52.9	76.78	51.19	38.39
79	85.5	57.0	42.7	102.6	68.4	51.3	108.2	72.2	54.1	78.51	52.34	39.25
80	87.5	58.3	43.8	105.0	70.0	52.5	110.8	73.9	55.4	80.36	53.58	40.18
81	89.7	59.8	44.8	107.6	71.8	53.8	113.6	75.7	56.8	82.36	54.91	41.18
82	92.0	61.4	46.0	110.4	73.6	55.2	116.5	77.7	58.3	84.52	56.35	42.26
83	94.6	63.1	47.3	113.5	75.7	56.7	119.7	79.8	59.9	86.85	57.90	43.42
84	97.3	64.9	48.7	116.8	77.8	58.4	123.2	82.1	61.6	89.36	59.57	44.68
85	100.3	66.8	50.1	120.3	80.2	60.2	126.9	84.6	63.5	92.07	61.38	46.03

Section 6 Troubleshooting

Section 6 Troubleshooting

Problem	Possible Cause	Solution
One row not planting seed.	Drive clutch release not engaged.	Engaged clutch release mechanism.
	Foreign material in hopper.	Clean hopper and finger carrier mechanism.
	Seed hopper empty.	Fill seed hopper.
	Row unit drive chain off of sprocket or broken.	Repair or replace drive chain.
	Drive not functioning.	Inspect all drives.
Drive release does not engage properly.	Drive release shaft isn't aligned properly with meter drive shaft.	Align drive mechanism. See "Meter Drive Adjustment".
Unit is skipping.	Foreign material or obstruction in meter.	Clean out and inspect.
	Finger holder improperly adjusted.	Adjust to proper setting. (22 to 25 inch pounds torque)
	Loose finger holder.	Adjust tension of finger pickup.
	Broken fingers.	Replace fingers and/or springs as required.
	Planting too slowly.	Increase planting speed to within recommended range. See charts for correct speed.
Planting too many doubles.	Planting too fast.	Stay within recommended range.
	Lose finger holder.	Adjust to specifications (22 to 24 inch pounds torque)
	Worn brush in carrier plate.	Inspect and replace if necessary.
Over planting.	Worn carrier plate.	Inspect and replace if necessary.
Under planting.	Belt installed backwards.	Remove and install correctly.
	Weak springs.	Replace.
	Spring not properly installed.	Remove finger holder and correct.
	Seed belt catching or dragging.	Replace belt.
	Brush dislodging seed.	Replace brush.
Irregular or incorrect seed spacing.	Driving too fast.	Check chart for correct speed.
	Wrong tire pressure.	Inflate tires to correct air pressure.
	Drive wheels slipping.	Reduce down pressure on row unit down force springs.
	Wrong sprockets.	Check planting rate charts for correct sprocket combinations.
Seed spacing not as indicated in charts.	Wrong tire pressure.	Inflate tires to correct air pressure.
	Inconsistent seed size.	Do field check and adjust sprockets accordingly.
	Wrong sprockets.	Check chart for correct sprocket combination.
	Charts are approximate.	Slight variations due to wear may produce seed spacing variations.
Scattering of seeds.	Planting too fast.	Reduce planting speed.
	Seed tube improperly installed.	Check seed tube installation.
	Seed tube worn or damaged.	Replace seed tube.

Section 6 Troubleshooting

Problem	Possible Cause	Solution
Low count.	Meter rpms too high.	Reduce planting speed.
	Lack of lubrication causing seeds not to release from seed disc properly.	Use graphite as recommended.
	Seed size too large for seed disc being used.	Switch to smaller seed or use proper seed disc. See Brush Meter on page 22.
	Seed treatment buildup in brush meter.	Reduce amount of treatment used and/or thoroughly mix treatment with seed.
Low count at low rpms and higher count at higher rpms	Foreign material lodged in upper retaining brush.	Remove seed disc and remove foreign material from between brush holder and bristles. Clean with compressed air.
	Worn upper retaining brush.	Replace brush.
Low count at higher rpms and normal count at low rpms	Seed disc worn in agitation groove area.	Replace seed disc.
High count	Seed size too small for seed disc.	Switch to larger seed or proper seed disc.
	Incorrect seed rate transmission setting.	Reset transmission.
	Upper brush too wide (fanned out) for small seed size.	Replace upper brush.
Upper retaining brush laid back	Seed treatment buildup on brush.	Remove brush and wash with soap and water. Dry thoroughly before reinstalling.
	Buildup of foreign material at base of brush.	Remove brush holder and brush. Clean with compressed air and reinstall.
Seed tubes and/or openers plugging.	Allowing planter to roll backward when lowering.	Lower planter only when tractor is moving forward.
	Turning tractor steering wheel when planter is down and stationary. (Four Wheel Drive tractors only.)	Avoid turning tractor when planter is down and stationary.
Inconsistent seed depth.	Rough seed bed.	Adjust down pressure springs.
	Partially plugged or improperly installed seed tube.	Inspect and clean. Ensure seed tubes are hooked properly in unit shank.
	Seed tube improperly installed.	Install properly.
Planter will not lower.	Pressure and return hoses not fully engaged in SCV outlets	---
Planter frame raises or lowers slowly.	Lower tractor hydraulic pressure.	Tractor standby pressure must be a minimum of 15.
	SCV not in fast position.	---
Erratic or uneven lift.	Air in hydraulic system.	Remove air.
Planter will not raise.	Tractor SCV bypassing oil.	Readjust SCV lever linkage. (See Tractor Operator's Manual.)
All row units not planting on planter.	Bolt in countershaft sprocket to seed transmission sheared.	Repair cause of pin shearing and replace cotter pin.
	Loss of power to point row clutches	Check control box, wiring and fuses. See control box schematic in Figure 6-1 on page 49.
Right or left side does not plant.	Loss of power to point row clutches.	Check wiring and fuses.
Closing wheels leave severe imprint in soil.	Too much spring force.	Adjust closing wheel spring.
Closing wheels not firming soil around seed	Insufficient spring force.	Adjust closing wheel spring.
Closing wheel running on top of seed furrow.	Improper centering.	Realign.
Closing wheels not applying equal force.	---	Relevel.

Section 6 Troubleshooting

Problem	Possible Cause	Solution
Consistent shearing of drill shaft cotter pin.	Drill shaft not aligned properly.	Loosen bearing and align shaft.
Drive wheel chain consistently falls off.	Chain may be too long.	Remove offset link.
	Chain links stiff.	Oil or replace chain.
	Chain dislodged by trash.	Add trash guards.
Markers not alternating.	Marker hoses not connected to marker valve correctly.	---
	Air in marker valve.	Bleed marker hydraulic system.
	Marker valve defective.	Replace valve. See your Great Plains dealer.
Marker floats off ground.	Air in hydraulic system.	Bleed marker lift cylinder.
	Alternator valve defective.	Replace valve. (See your Great Plains dealer.)
	Leaking tractor SCV.	---
	Marker cylinder not dropping down into J-slot. (Hose loop too short.)	Lengthen marker hydraulic hose loops.
Hydraulic marker functioning improperly.		Check all hose fittings and connections for air and oil leaks.
		Check tractor hydraulic oil level.
		Check all bolts and fasteners.
		If markers do not alternate: a. Check tractor flow controls and set to maximum oil flow.
		If problem still exists: b. Remove Valve, disassemble, and check for contamination or damage to spool. Re-assemble.
Blade does not mark.		The maximum marker down float is limited by the slot in the pivot link. If the blade does not drop down to follow depressions in the field, make sure the marker cylinder is fully extended.
		The blade may be reversed to pull dirt in or throw dirt out depending on soil conditions.
For the following, refer to Figure 6-2.		
Wings do not fold evenly.	Did not retract fully in transport position	Remember to fully retract
	Large differential in wing weights	Keep add-on items and hopper fill even
	O-ring leaking in lower cylinder if uneven unfolding	replace O-ring.
	O-ring leaking in upper cylinder if uneven folding	replace O-ring
	Contamination in combiner spool orifice of slower wing	remove contamination from spool.
Does not fold or unfold.	Selector valve handle not fully shifted	Shift selector valve
	Selector valve hand bent	Replace handle
	Tractor hydraulic pressure below 2150 psi	Increase to 2150 psi if allowed by tractor manufacturer, or do not fold loaded.
Wings do not lift evenly with mainframe in field position.	Left or right wing does not lift evenly with mainframe	adjust wing flow control valves with planter loaded.
	Slave cylinder leaking	Replace O-ring in piston assembly with mainframe in field position.

Section 6 Troubleshooting

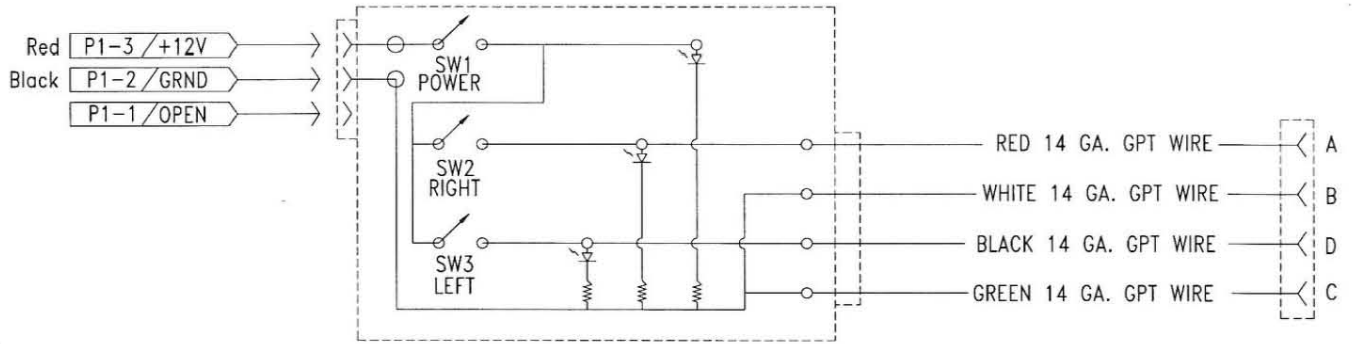

15877

Point Row Clutch Control Box Schematic
Figure 6-1

WARNING!

Escaping fluid under pressure can penetrate the skin causing serious injury. Avoid the hazard by relieving pressure before disconnecting hydraulic lines. Use a piece of paper or cardboard, NOT BODY PARTS, to check for suspected leaks. Wear protective gloves and safety glasses or goggles when working with hydraulic systems. If an accident occurs, see a doctor immediately. Any fluid injected into the skin must be surgically removed within a few hours or gangrene may result.

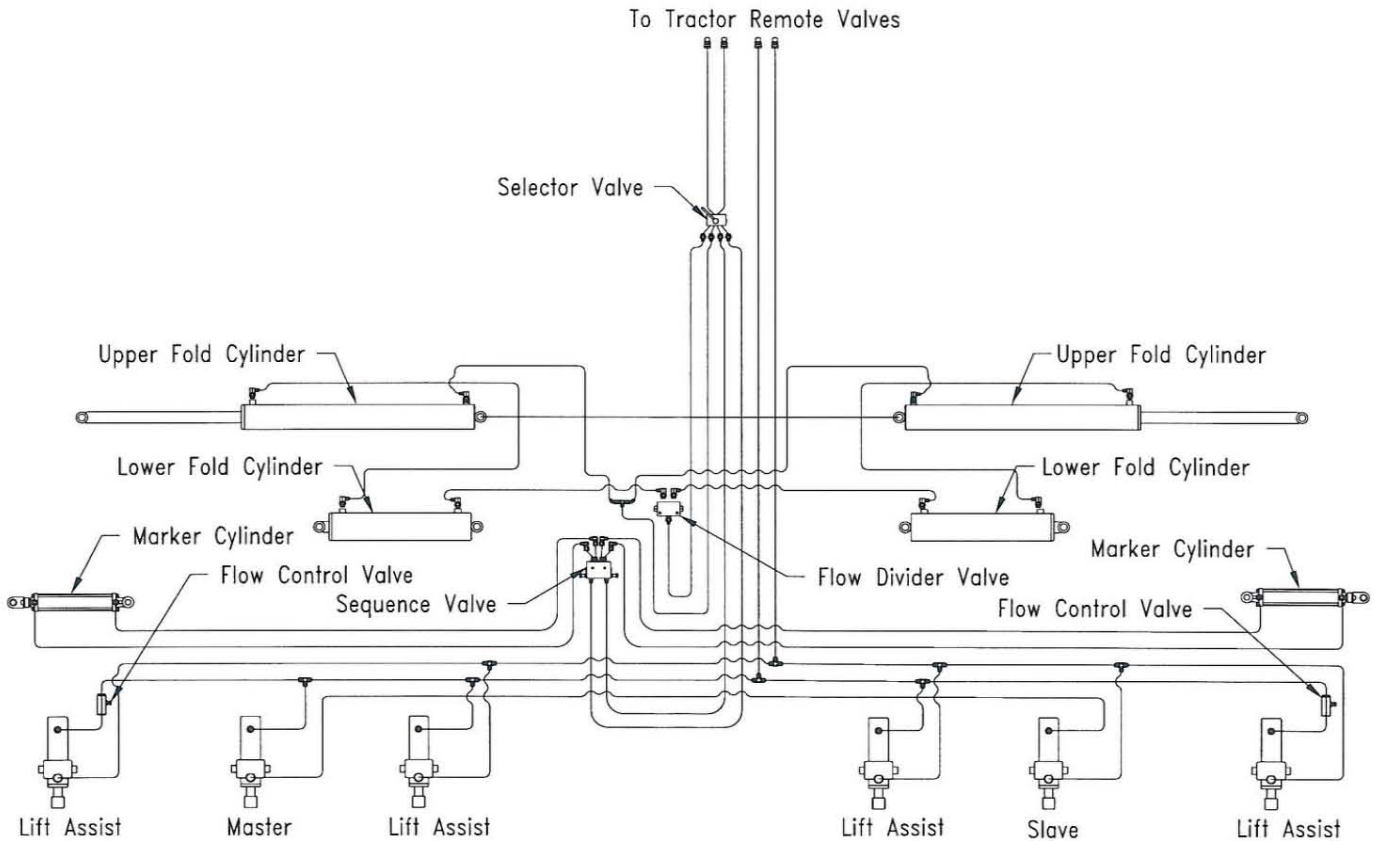

15896

Hydraulic Schematic
Figure 6-2

Section 7 Maintenance and Lubrication

Installing Transport Locks

! WARNING!

Install all six (6) transport locks on raised planter before working around or underneath. Failure to do so could result in serious injury or death or damage to the planter.

Transport locks are located on all gauge wheel cylinders. See Figure 7-2.

Refer to Figure 7-1:

Raise planter to transport position with tractor remote cylinder operating lever. Pivot transport lock into position on wheel module cylinder rods with transport lock handle. Lower to lock.

NOTE: Transport locks are provided for safety when performing normal maintenance and adjustments with the planter raised.

! WARNING!

Escaping fluid under pressure can penetrate the skin causing serious injury. Avoid the hazard by relieving pressure before disconnecting hydraulic lines. Use a piece of paper or cardboard, NOT BODY PARTS, to check for suspected leaks. Wear protective gloves and safety glasses or goggles when working with hydraulic systems. If an accident occurs, see a doctor immediately. Any fluid injected into the skin must be surgically removed within a few hours or gangrene may result.

Fasteners

When working on the planter torque all bolts, screws, and

nuts to the correct values listed in the *Torque Values Chart for Common Bolt Sizes* in "Section 10 Appendix" on page 73. Check latches and other fasteners on the planter to prevent failures in the field.

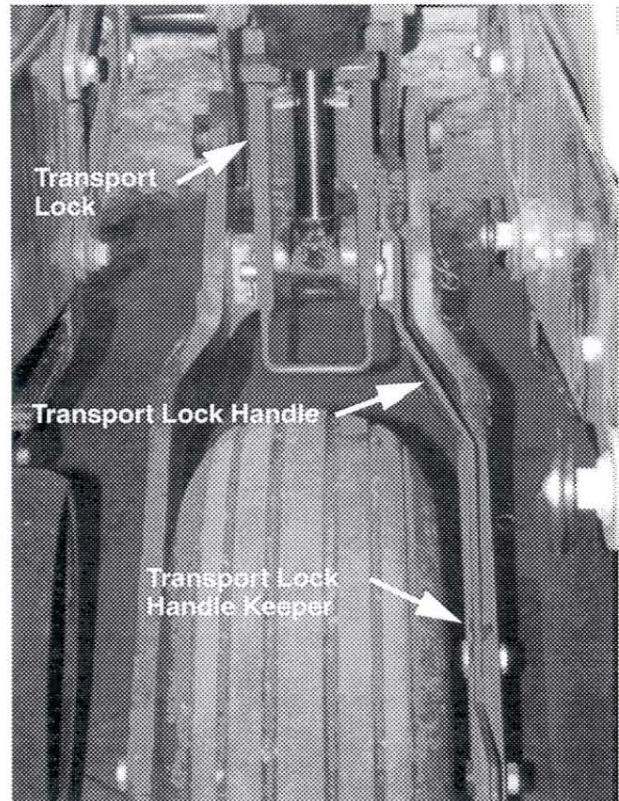

Cylinder Stop
Figure 7-1

15858

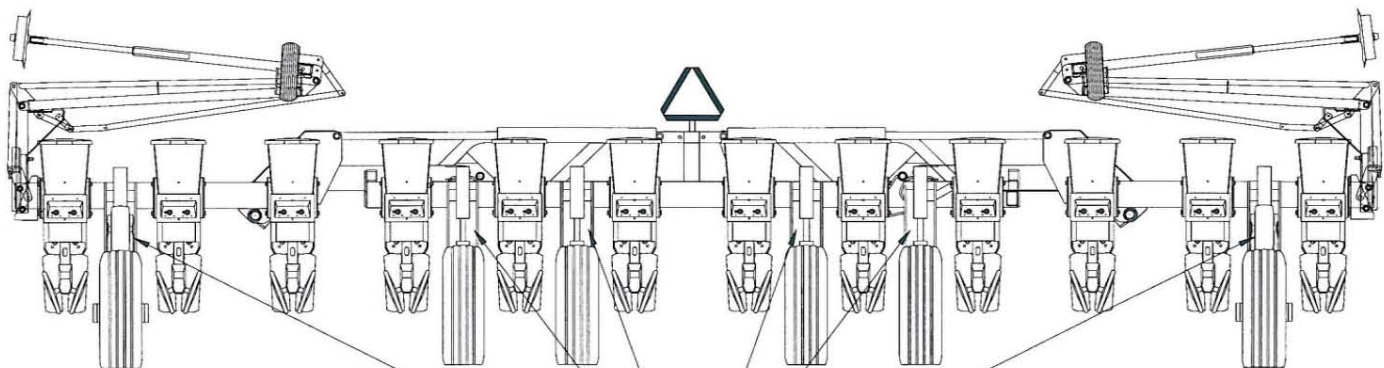

Cylinder Lock Locations

Figure 7-2

15879

Replacing Drill Shaft Cotter Pins and Countershaft Shear Pins

Refer to Figure 7-3:

The cotter shear pins (A), which connect the drill shaft to the transmission and shear pins (B) which connect countershaft to transmission, will shear when an excessive load is put on the drill shaft.

NOTE: If drill shaft binds due to misalignment, loosen bolts on drill shaft bearings on planting units. Make certain shaft turns freely and tighten bolts.

If countershaft binds due to misalignment, loosen bolts on transmission bearings. Make certain shaft turns freely, then tighten bolts.

Infrequent or improper lubrication causes "binding" of moving parts within the planter. This "binding" will cause the cotter shear pins to shear, thus preventing breakage of planter parts.

If either cotter pin shears, turn the drill shaft by hand to locate where the binding is occurring. When the drill shaft can be turned freely by hand, replace the cotter pin.

NOTE: Replace the cotter shear pins only with cotter shear pins of the same size. Do not replace with other type pins.

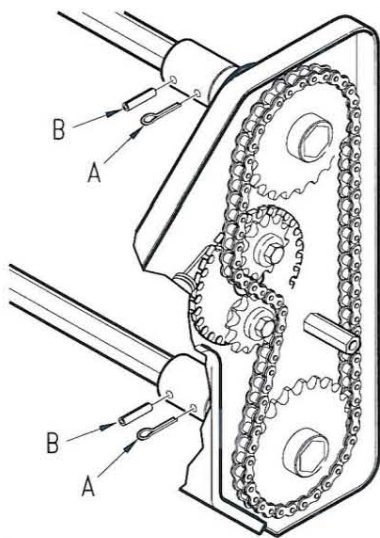

Transmission Cotter Pins & Shear Pins 15046
Figure 7-3

Finger Pickup Meter

To inspect and repair finger-pickup meters, remove meter from hopper, then remove three 1/4-inch bolts (#1) on the meter baffle (2) to gain access to the finger mechanism.

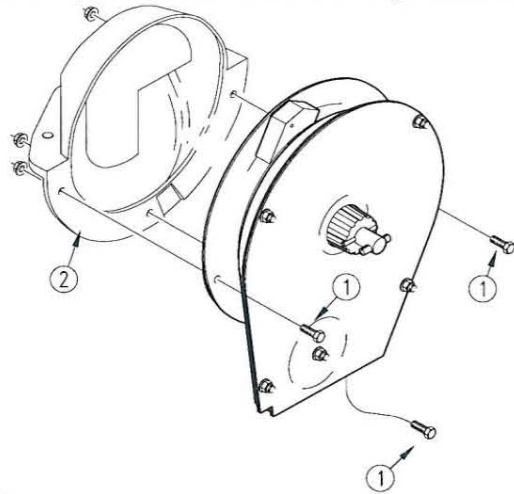

Figure 7-4
Disassemble Finger-Pickup Meter

Rotate meter-input shaft by hand to check the fingers. The fingers (#1) should be against the carrier plate (#2) in the area marked closed in Figure 7-5 and raised in the area marked open.

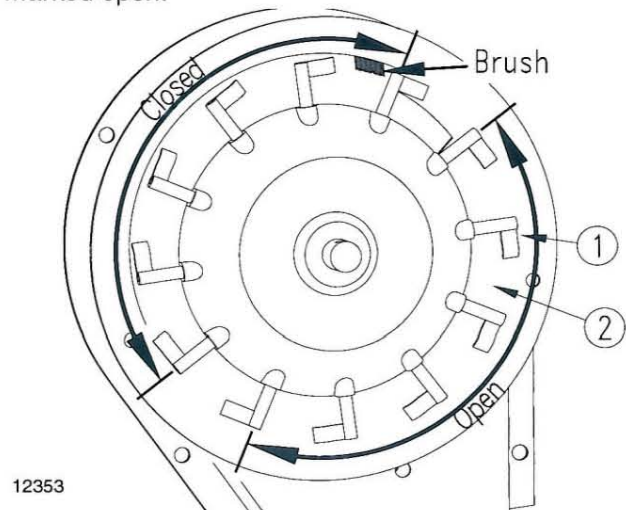

Figure 7-5
Inspecting Meter Fingers

Inspect brush for wear. The brush should cover at least half of a finger tab. Replace brush after every 100 acres of planter operation.

Clean chaff and debris from meter after every 50 hours of planter operation. To clean meter, see Figure 7-6.

1. Remove cotter pin (#1), cage nut (#2) and adjusting nut (#3) from shaft.
2. Lift finger assembly (#4) off shaft and clean. Replace worn fingers and springs after 250 to 300 acres of operation. To remove a finger, lift finger out of slot. When

Section 7 Maintenance and Lubrication

replacing a finger, place the springs so the open side of the spring loop faces the inside of the spring housing.

3. Inspect carrier plate (#5) for seed indentations and wear. Replace carrier plate when wear affects seeding accuracy.

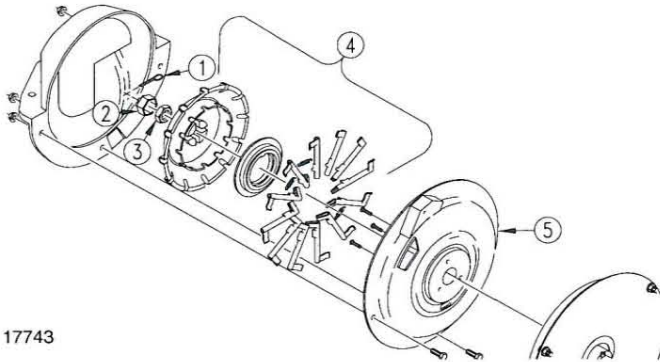

17743

Figure 7-6
Disassemble Meter for Cleaning

4. Reassemble finger housing onto carrier plate. When reassembling, align notch in finger-housing cam (#1) with notch on bearing housing so finger housing is flush with the carrier plate. The meter will function improperly if notches are not aligned.

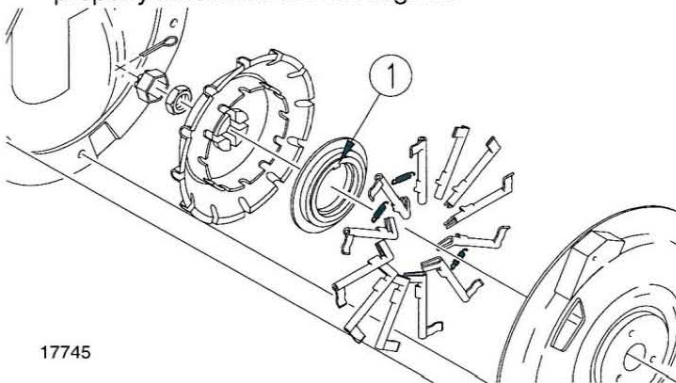

17745

Figure 7-7
Meter Reassembly

5. With finger assembly against carrier plate, tighten adjusting nut until it is snug, then turn an additional one-third turn. Proper torque is 22 to 25 inch-pounds at the meter-input shaft. Turn meter by hand to make sure the meter is not over tightened.

IMPORTANT: Check tightness of the adjusting nut on the meter after the first day of operation and periodically thereafter.

6. Reassemble cage nut and cotter pin. Reassemble baffle and attach meter to hopper.

Periodically check the meter belt. Refer to Figure 7-8.

1. Remove four bolts (#1) from belt housing (#2). Remove bolt holding the belt roller (#3). Remove belt housing.

2. Inspect belt. Replace belt if necessary.

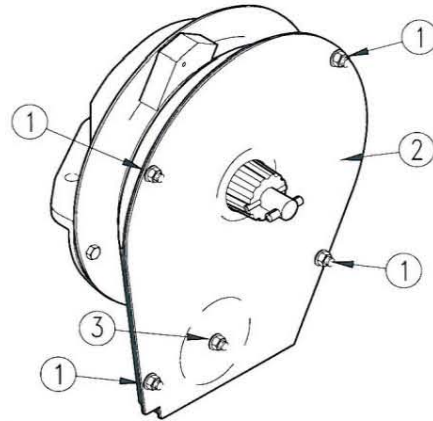

14966

Figure 7-8
Belt Inspection

3. To replace a worn or broken belt, refer to Figure 7-9. Be certain paddles (A) are oriented as shown. Belt drive wheel (B) may be removed by removing spring pins (C).

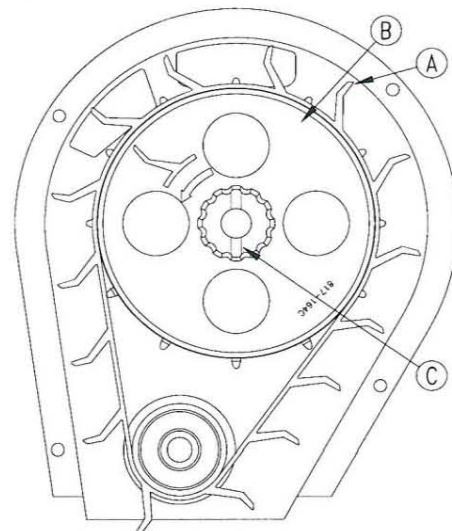

15049

Figure 7-9
Belt Installation

4. Reassemble meter in reverse order.

Brush-Type Seed Meter

Daily Maintenance

Inspect the brush meter daily for buildup of foreign material on the seed disc, particularly in the seed loading slots.

Remove seed disc (#1) by removing the two wing nuts (#2), see Figure 7-10. Clean disc by washing it with soap and water. Check for cracked seed, hulls, etc. lodged between brush holder and stainless steel wear band. Clean brush areas of meter housing by using compressed air.

Cleaning Brush Meter for Storage

Refer to Figure 7-10:

1. Remove brush meter from seed hopper by removing two 5/16" x 1" long bolts and 5/16" nuts which secure meter to hopper.
2. Remove seed disc (#1) by removing the two wing nuts (#2).
3. Wash seed disc with soap and water.
4. Unscrew three hex head screws (#3) from brush holder (#4) and remove brush holder and retaining brush (#5).
5. Unscrew three hex head screws (#6) from lower brush (#7) and remove brush and wear band (#8).
6. Wash all parts including meter housing (#9) with soap and water. Dry thoroughly.
7. Reassemble brush meter in reverse order except for seed disc.

To install retaining brush (#5) first position brush making sure the base of brush is tight against bottom of meter housing. Install brush holder (#4) and three hex head screws (#3). Tighten center screw first, then left screw and right screw last.

8. Store brush meter and seed disc in a clean, dry place.

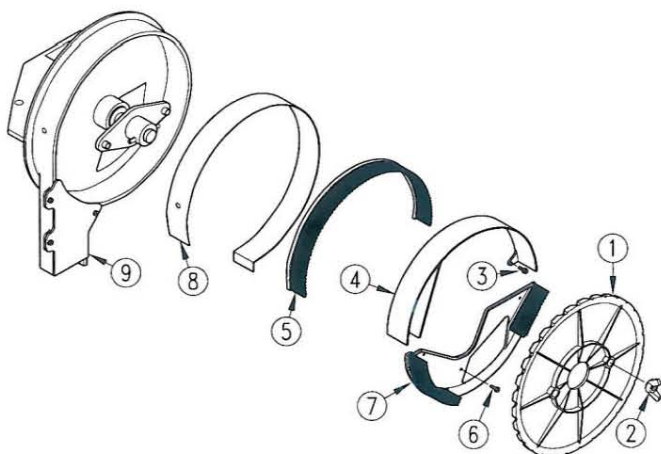

Brush Meter
Figure 7-10

15869

Seed Disc Wear

Inspect the seed disc for wear at disc attaching holes, seed loading slots and seed pockets.

Most wear will be found between seed loading slots. To measure for wear, lay a straight edge across the surface of disc. Measure the gap between disc and straight edge. If this measurement is greater than .075" and accuracy is starting to drop off at higher meter rpms, then replace seed disc.

Scraper Weldment

The scraper weldment between the disks will periodically need replacing. These components scrape dirt off the disks and protect the seed tube.

To inspect or replace the spreader or scraper do as follows:

1. Remove both side gauge wheels and the arms from the row unit.
2. Remove the disk blades.



CAUTION!

Disk blades wear very sharp. Handle with care.

3. Remove 3/8" roll pin holding the scraper weldment.
4. If the sides of the seed tube are worn, replace the scraper weldment. Replace roll pin if needed.
5. Install the scraper weldment with 3/8" roll pin.
6. Install the disk and torque the bolt to the correct value as listed in *Torque Values Chart for Common Bolt Sizes* in "Section 10 Appendix" on page 73.
7. Install the gauge wheels according to directions under *Gauge Wheels*.

Disk



CAUTION!

Disk blades wear very sharp. Handle with care.

As the disks on the row unit wear, removal of shims may be required to maintain contact point. To remove disk do as follows:

1. Remove side gauge wheels and arm from the row unit.
2. Remove 3/4" bolts retaining the disks.
3. Measure disk diameter, if disk measures 14 1/2" or less replace disk.
4. If contact is to be increase, move shims from behind disk to outside disks. This will increase the contact between the disks.
5. Install disks and tighten 3/4" bolts to torque values in Specification Section.
6. Install gauge wheels and arms according to directions in this section.

Section 7 Maintenance and Lubrication

Gauge Wheels

Periodically check gauge tires to be sure there is contact or less than a 1/16" gap between the tires and disks.



CAUTION!

Gap between depth gauge wheel and disk blade may pinch fingers. Be careful when checking.

For installation or adjustments proceed as follows:

1. Remove the 1/2" bolt holding arm on to the shank.
2. If the tire needs to be closer to the disk, move an appropriate amount of shims from the inside of the arm to the outside, see Figure 7-11. Each shim is .050 thick.

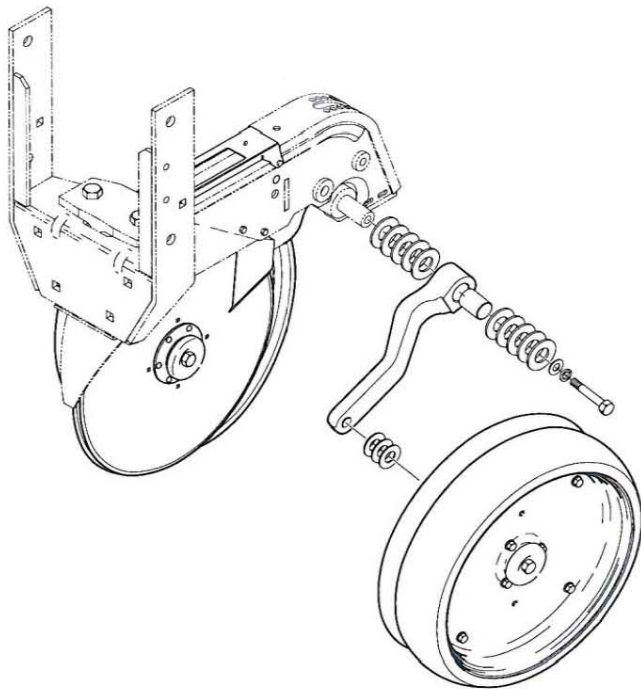

Gauge Arm, Spindle, and Shims 12354
Figure 7-11

3. Install the arm and the shims onto the spindle. Tighten 1/2" bolt to the correct torque value as listed in the *Torque Values Chart for Common Bolt Sizes* in "**Section 10 Appendix**" on page 73.
4. Check clearance or contact of the tire and disk. The gauge wheel should fall freely when lifted.
5. Repeat steps 1 through 4 if necessary.

Outside Scrapers

The row units are equipped with outside disk scrapers to remove dirt from the discs.

Periodically check the scrapers as follows:

1. Remove the gauge tires to inspect the scrapers.
2. Make sure the scrapers are contacting the disk with some pressure.
3. If scrapers are not contacting the discs properly, bend and twist the scrapers as required to establish contact. If the scraper is worn too much, replace it by removing the two 1/4" bolts. Bolt the new scraper in place and torque the bolts to correct values as listed in the *Torque Values Chart for Common Bolt Sizes* in "**Section 10 Appendix**" on page 73.

Chain Tension

The planter is equipped with spring loaded idlers to maintain tension in the chains. As the chains wear and stretch, the link(s) may be removed to provide proper chain length and tension. Check and replace broken springs and bushings on idlers. For the correct operation of the planter check all chain routings.

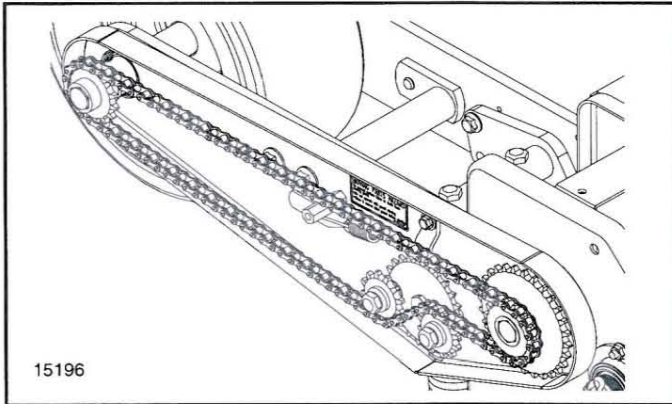

Drive Gauge Wheel Chain Routing

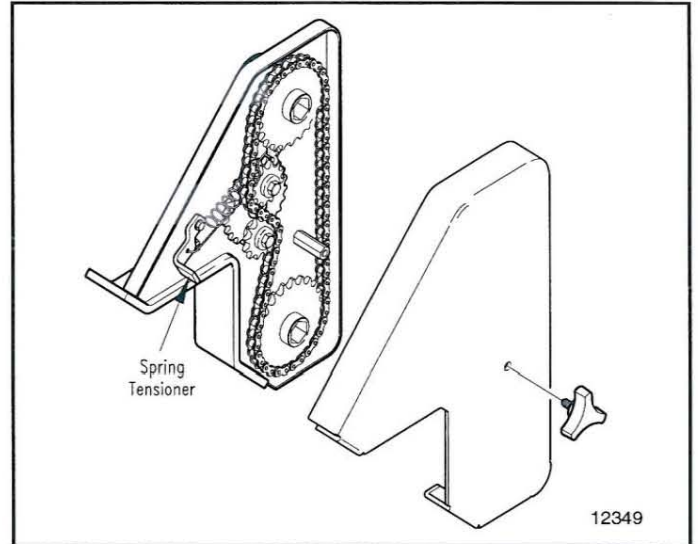

Transmission Chain Routing

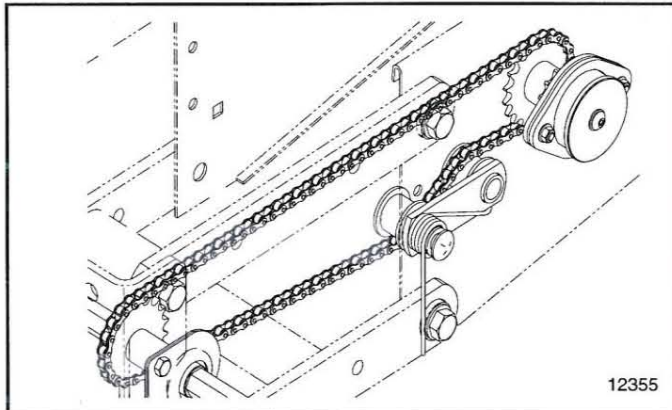

Meter Drive Chain Routing

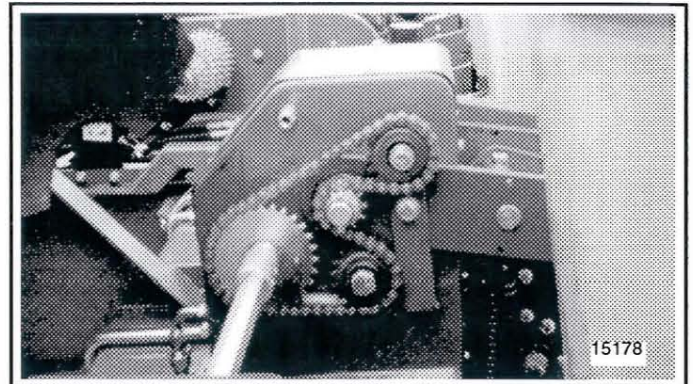

Reverser Drive Chain Routing

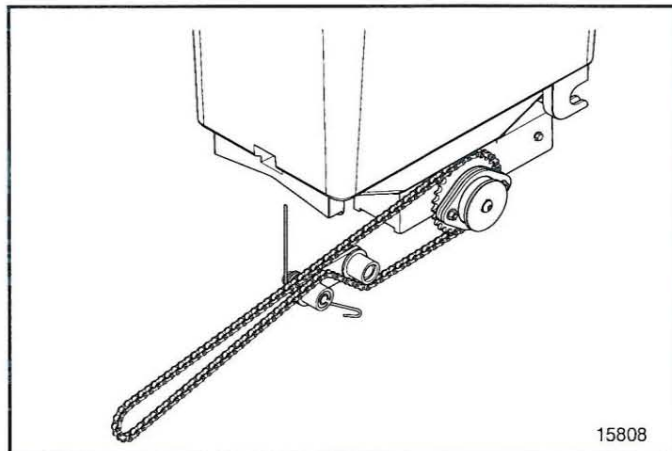

Granular Chemical Drive Chain Routing

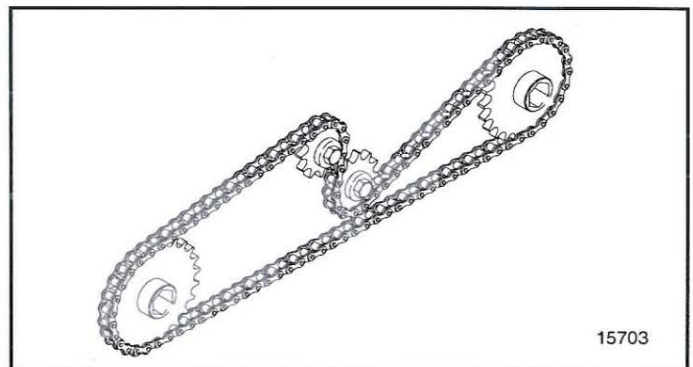

Liquid Fertilizer Chain Routing

Section 7 Maintenance and Lubrication

Cleaning Insecticide and/or Herbicide Hoppers

DANGER!

Agricultural chemicals can be dangerous. Follow the instructions of the chemical manufacturer when cleaning hoppers and handling insecticides or herbicides.

IMPORTANT: Under certain humidity or moisture conditions, material may tend to cake. When this happens, thoroughly clean hoppers at the end of each day's use.

To remove hoppers, proceed as follows:

1. Disengage drive clutch.
2. Unlatch.
3. Lift off.
4. Clean thoroughly.

Cleaning Liquid Fertilizer Tanks

DANGER!

Agricultural chemicals can be dangerous. Follow the instructions of the chemical manufacturer when cleaning hoppers and handling insecticides or herbicides.

Although the tanks are made of a highly durable and corrosion resistant plastic, proper maintenance is required.

Rinse the tank with water when changing from one solution to another.

Rinse tank thoroughly with water after each season or before any shutdown lasting over one week.

Do not allow sludge to accumulate in the bottom of the tank.

Do not leave fertilizer in the tanks if the temperature is expected to drop below 40 degrees as some types of liquid fertilizers will begin to crystallize at this temperature.

To clean tanks, proceed as follows:

5. Remove lids from tanks.
6. Turn valve to elbow.
7. After cleaning tanks, close shutoff valve, replace cap on metering pump and replace lids on tanks.

Squeeze Pumps

Refer to Figure 7-12:

During periods when the pump is not being used, these important steps are recommended to prevent hose deformation and prolong hose life.

1. Unscrew (about 1/2 inch) the wing nuts holding the spring anchor bar to the pump frame. This releases pressure against the hoses.
2. Loosen the wing nuts on the discharge manifold and shift the manifold rearward.
3. Store out of sunlight.

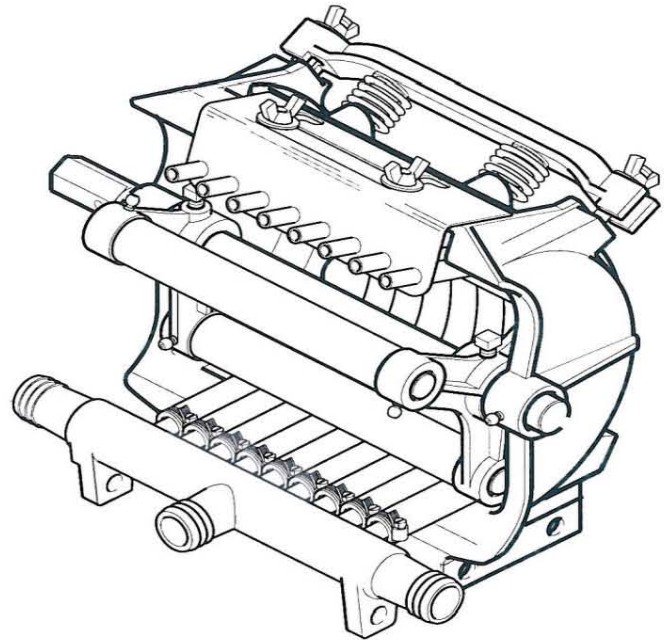

Relaxing Pressure on Metering Hoses
Figure 7-12

12409

Marker Breakaway Protection

The marker arm is attached to the marker body with a 5/16" breakaway bolt. If excessive force is put on the marker during operation, the bolt will break, allowing the marker arm to swing away rather than cause damage to the marker.

NOTE: The breakaway bolt is a 5/16"-18 x 1 1/2" long grade 2 on planter only (GP #802-295C). If it breaks, it must be replaced by an equivalent grade 2 bolt to prevent marker damage.

Storage

To extend the life of your planter follow the recommendations for removing the planter from storage and storing the planter during the off season.

Beginning of the Season Service

Before using the planter after it has been stored, inspect the seed hoppers for cleanliness to be certain the seed will flow from hoppers freely.

Thoroughly inspect the planter unit for loose parts and adjust as necessary. Check all bolts and replace worn parts to prevent failure in the field.

Clean any dirt or grease that may have accumulated on moving parts, and chains before operating the planter. This will prevent abrasive action that could cause excessive wear.

Section 7 Maintenance and Lubrication

When roller chains remain unused for several days, moisture in the air will accumulate on the chain, causing the chain to rust. This can, and will, become serious enough in time to cause the chain joints to become stiff, restricting their normal free movement. While very difficult to detect, this stiffness can encourage the chains to operate abnormally and disturb the smooth rotation of important meter components, causing deterioration in performance.

If the planter is not used for several days, or if oil has been removed from chains, etc. while cleaning the planter thoroughly lubricate chains with multipurpose chain lube.

IMPORTANT: Do not use chain lube or any other heavy petroleum base lubricant that may cause a buildup of dust or dirt in the sprocket or gear teeth.

Turn the meter drive shaft by hand to be sure the drive shaft and seed meter are free to turn. Rotate forward only, as assemblies are not designed to rotate in reverse.

Be certain all adjustments are made for the planting conditions to be encountered.

Service at the End of the Season

When planting is complete clean the seed and chemical hoppers. Remove all dirt, debris, chemicals, and fertilizer from the planter that may hold moisture and cause corrosion.

Use spray paint to cover scratches, chips, and worn areas on the planter to protect the metal.

Lubricate the planter as outlined in *Lubrication*. Pay careful attention to the lubrication of the chains to help prevent rusting.

Inspect the planter for worn or damaged parts. Make repairs and service during the off season to reduce down time in the field.

Place the 1 X 12 closing wheel handle in the middle slot to relieve the tension on the closing wheels. Move opener adjustment bar on heavy and medium down pressure spring packages to hole A, refer to Figure 4-7 on page 29.

Remove the finger pickup meters from the hoppers. Disassemble the meters and inspect them for wear. Make any repairs required at this time. Blow excessive debris from the meter. Wash the meters with mild soap and water. Dry the meters and spray a light coat of rust inhibitor on the meters. Reassemble and store in a dry place.

Thoroughly flush liquid herbicide system with clean water. Disconnect from tractor and completely drain all lines and components to prevent damage from freezing.

Store the planter in a clean, dry place with all tires out of the sun. A sheltering structure is best for overall protection, but a high quality tarp would suffice.

Section 7 Maintenance and Lubrication

Lubrication

Lubrication Legend

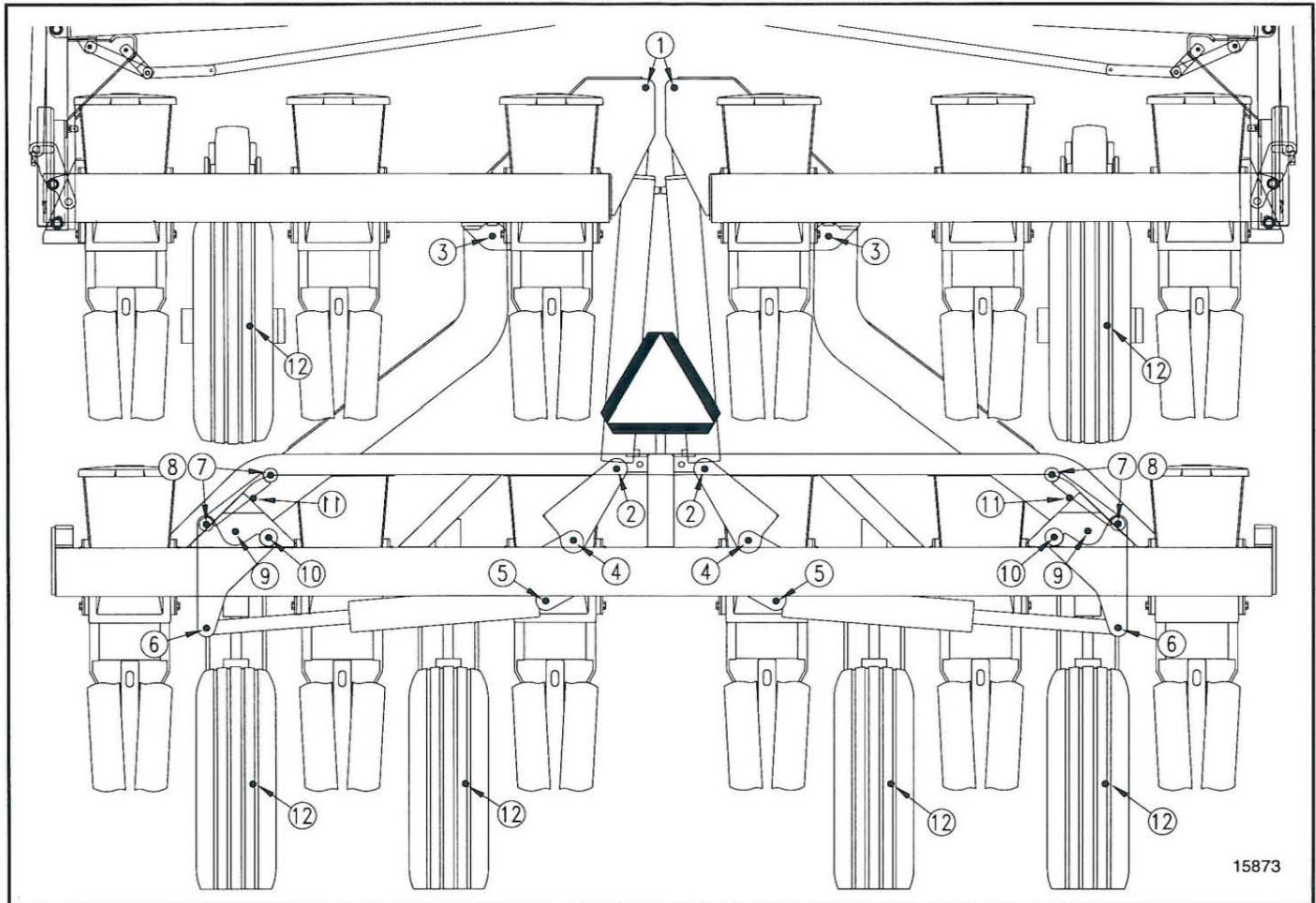
Multipurpose
spray lubeMultipurpose
grease lubeMultipurpose
oil lube50
Intervals at which
lubrication is required**Planter Pivot Point Grease Zerk Locations**

Twenty total locations

For detailed instructions on lubrication for these points see page 60 and page 61.

- | | |
|-----------------------------|----------------------------|
| 1. Slave cylinder rod end | 6. Master cylinder rod end |
| 2. Slave cylinder butt end | 7. Dogbone link |
| 3. Pivot arm & wing | 8. Dogbone link |
| 4. Pivot on float link | 9. Pivot arm & mainframe |
| 5. Master cylinder butt end | 10. Fold link pivot |
| | 11. Dogbone link stop |
| | 12. Wheel bearings |

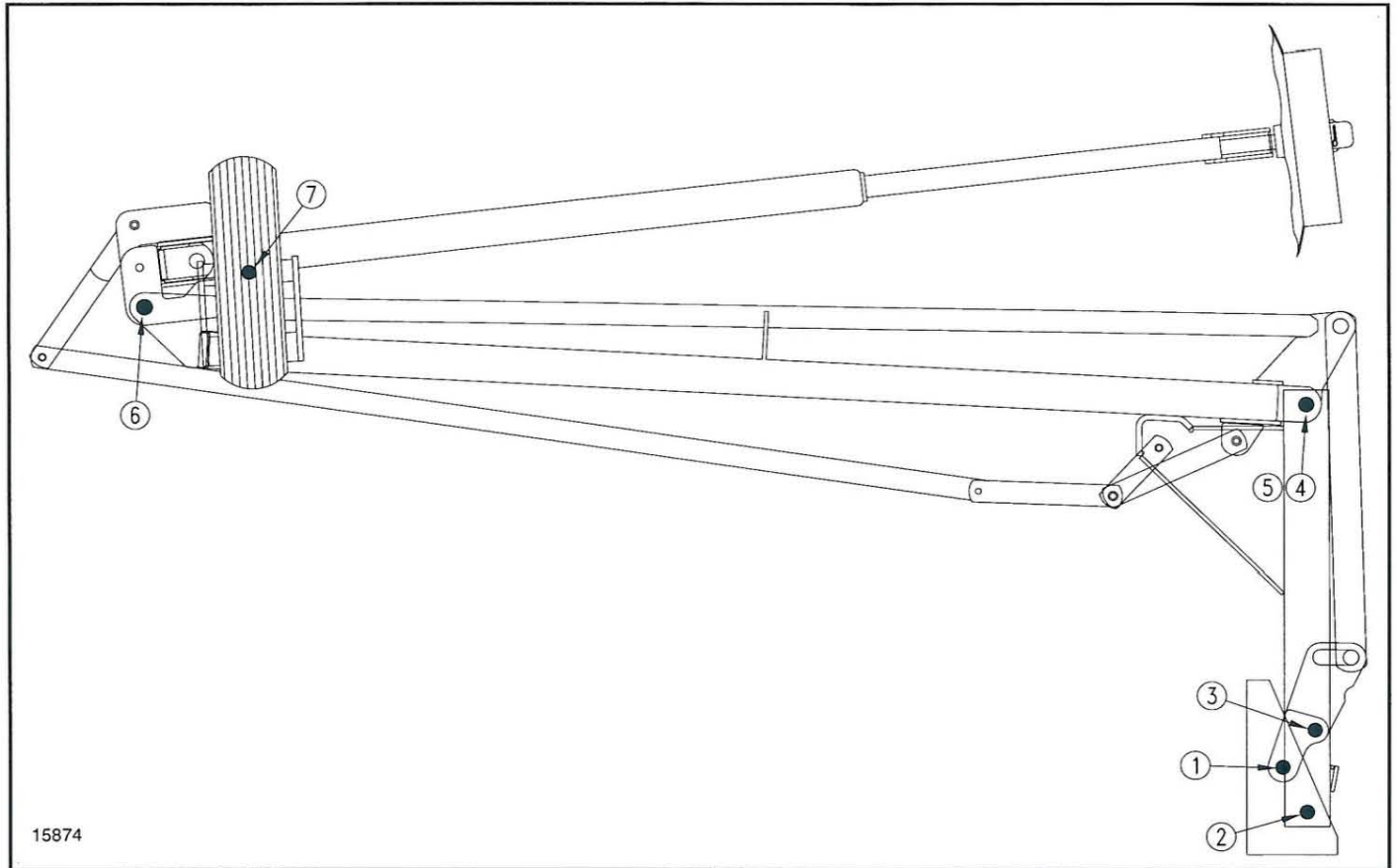

Marker grease zerk locations

Six locations per marker.

For detailed instructions on lubrication for these points see page 62 and page 63.

1. Cylinder rod end
2. Pin on mount
3. Link
4. Pivot at first/second stage arm
5. Pivot at first/second stage arm
6. Pivot at second/third stage arm
7. Wheel hub

Section 7 Maintenance and Lubrication

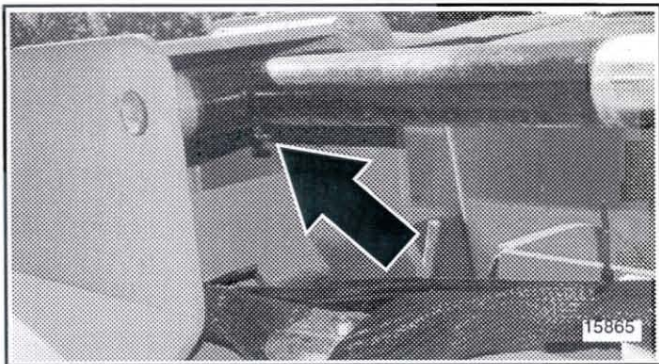
**Slave Cylinder Rod End**

Type of Lubrication: NLGI grade 2 or 3 grease lubricant.

Quantity: Until grease begins to emerge.

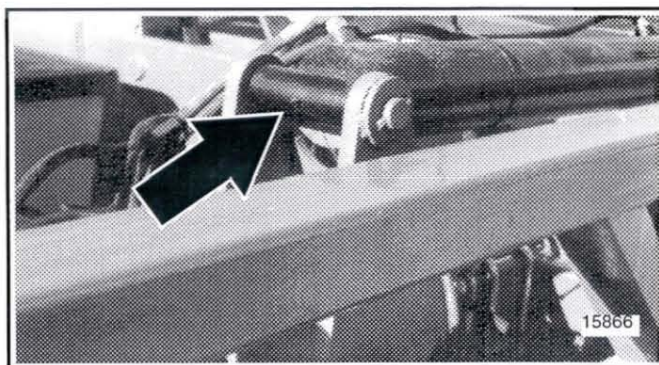
**Slave Cylinder Butt End**

Type of Lubrication: NLGI grade 2 or 3 grease lubricant.

Quantity: Until grease begins to emerge.

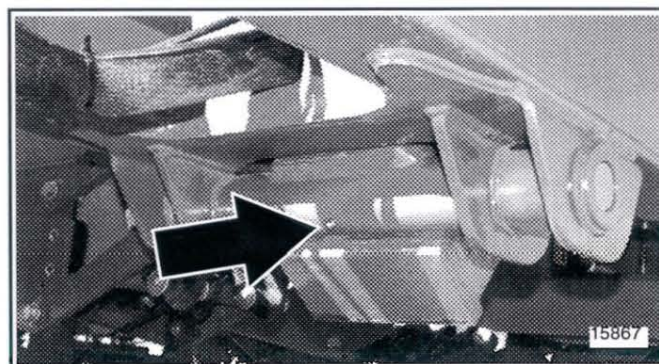
**Pivot Arm & Wing**

Type of Lubrication: NLGI grade 2 or 3 grease lubricant.

Quantity: Until grease begins to emerge.

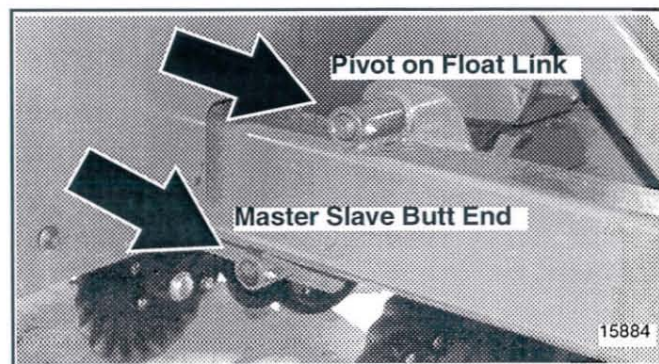
**Pivot on Float Link and Master Slave Butt End**

Type of Lubrication: NLGI grade 2 or 3 grease lubricant.

Quantity: Until grease begins to emerge.

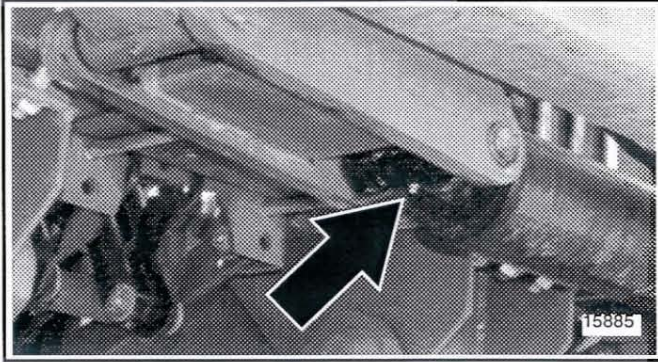

Master Cylinder Rod End

Type of Lubrication: NLGI grade 2 or 3 grease lubricant.

Quantity: Until grease begins to emerge.

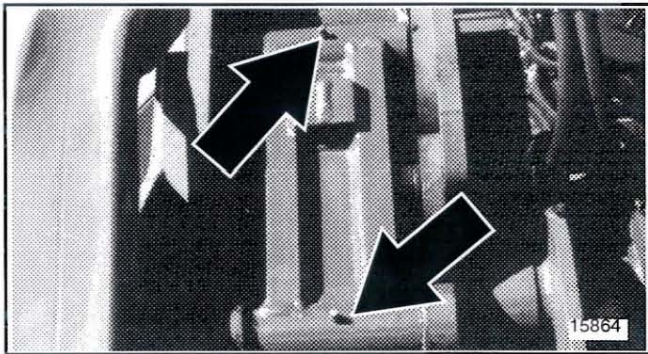

Dogbone Link

Type of Lubrication: NLGI grade 2 or 3 grease lubricant.

Quantity: Until grease begins to emerge.

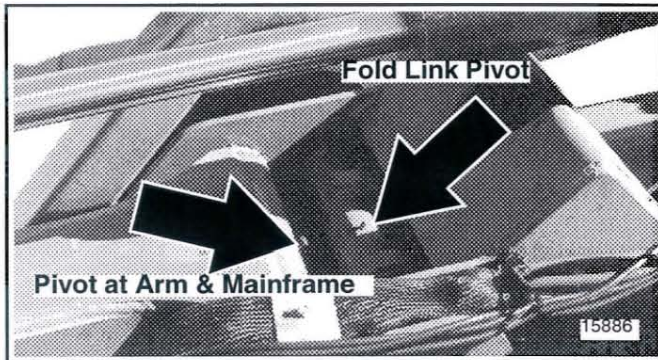

Pivot Arm & Mainframe and Fold Link Pivot

Type of Lubrication: NLGI grade 2 or 3 grease lubricant.

Quantity: Until grease begins to emerge.

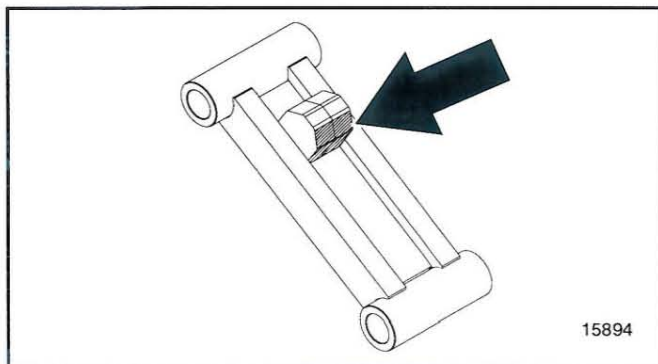

Dogbone Link Stop

The stop is located on the side opposite the grease zerks. Apply grease on shaded area.

Type of Lubrication: NLGI grade 2 or 3 grease lubricant.

Quantity: Coat stop well.

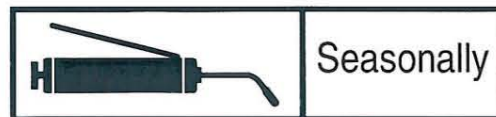
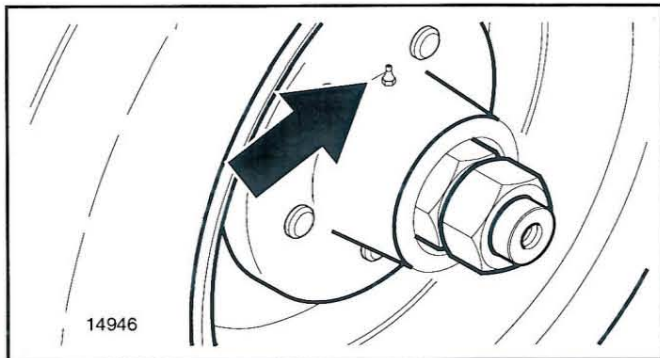

Section 7 Maintenance and Lubrication

**Wheel Bearings**

Lift the wheel off the ground. Move the tire in and out to check for end play. Check for roughness in the bearing by rotating the wheel. If the bearings are rough they should be inspected and replaced if necessary.

Type of Lubrication: NLGI grade 2 or 3 grease lubricant.

Quantity: Repack

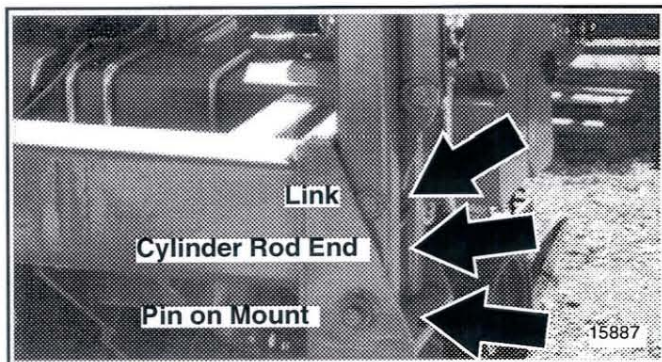
**Marker Cylinder Rod End, Pin on Mount and Link**

Type of Lubrication: NLGI grade 2 or 3 grease lubricant.

Quantity: Until grease begins to emerge.

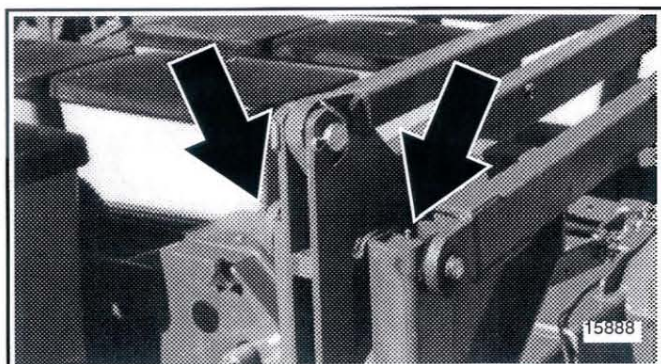
**Marker Pivot at First Stage/Second Stage Arm**

Type of Lubrication: NLGI grade 2 or 3 grease lubricant.

Quantity: Until grease begins to emerge.

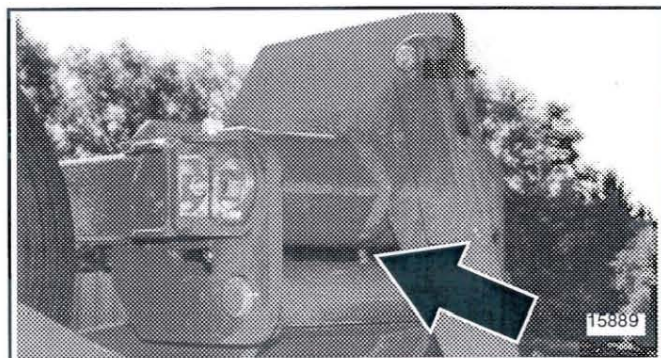
**Marker Pivot at Second Stage/Third Stage Arm**

Type of Lubrication: NLGI grade 2 or 3 grease lubricant.

Quantity: Until grease begins to emerge.

Section 7 Maintenance and Lubrication

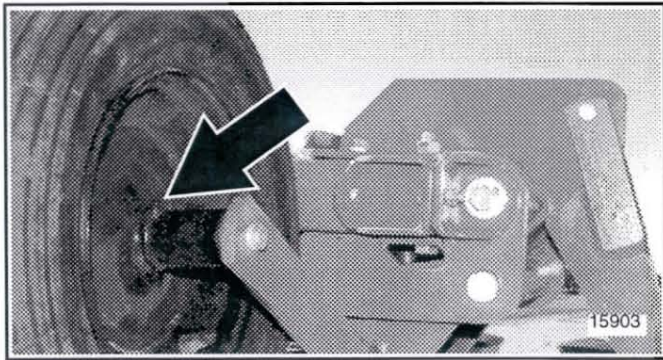

	
---	---

Marker Wheel Hub

Type of Lubrication: NLGI grade 2 or 3 grease lubricant.

Quantity: Until grease begins to emerge.

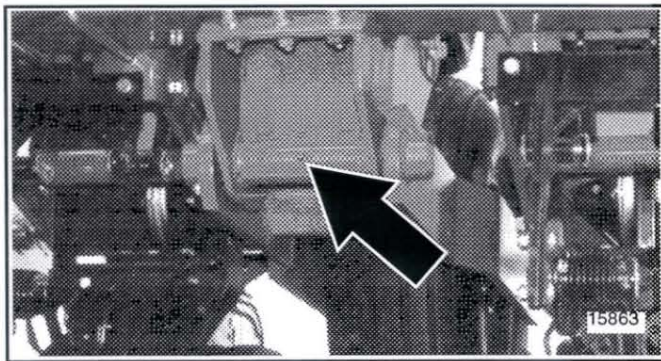

	
---	---

Gauge Wheel Module

One grease zerk per module (6 total).

Type of Lubrication: NLGI grade 2 or 3 grease lubricant.

Quantity: Until grease begins to emerge.

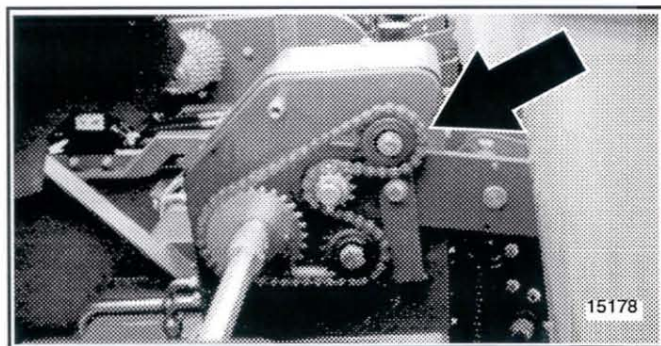

	
---	---

Reverser Chains

Lubricate all chains at intervals to maintain freedom at every chain link joint. Use a multipurpose spray lubricant on chains, because it penetrates into the rollers on the chain. Spray chains if planter is going to be idle to prevent the chains from rusting and becoming stiff. Stiff chains will cause metering inaccuracies.

Type of Lubrication: Multipurpose Chain Lube

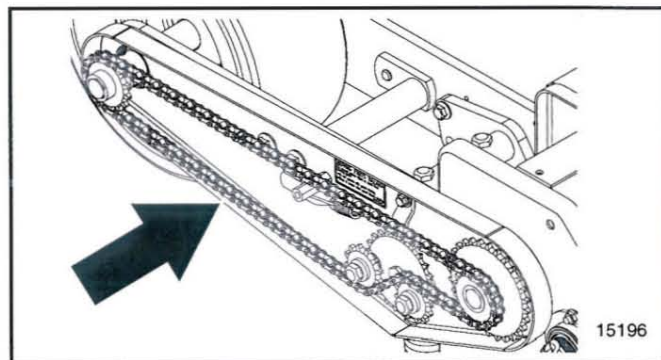

	
---	---

Contact Drive Chain

Lubricate all chains at intervals to maintain freedom at every chain link joint. Use a multipurpose spray lubricant on chains, because it penetrates into the rollers on the chain. Spray chains if planter is going to be idle to prevent the chains from rusting and becoming stiff. Stiff chains will cause metering inaccuracies.

Type of Lubrication: Multipurpose Chain Lube

Section 7 Maintenance and Lubrication

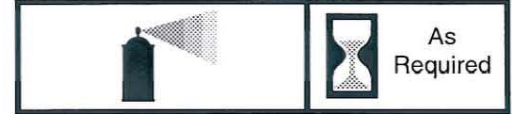
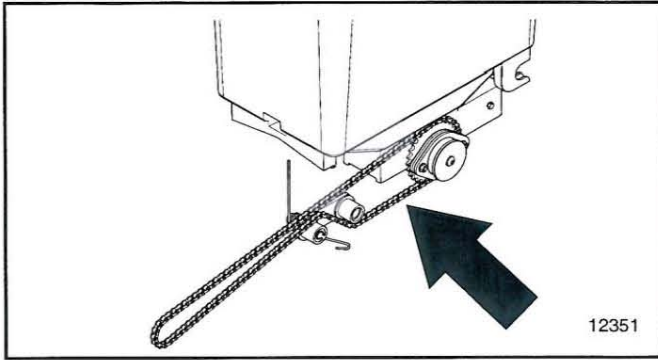
**Seed and Chemical Meter Chains**

Lubricate all chains at intervals to maintain freedom at every chain link joint. Use a multipurpose spray lubricant on chains, because it penetrates into the rollers on the chain. Spray chains if planter is going to be idle to prevent the chains from rusting and becoming stiff. Stiff chains will cause metering inaccuracies.

Type of Lubrication: Multipurpose Chain Lube

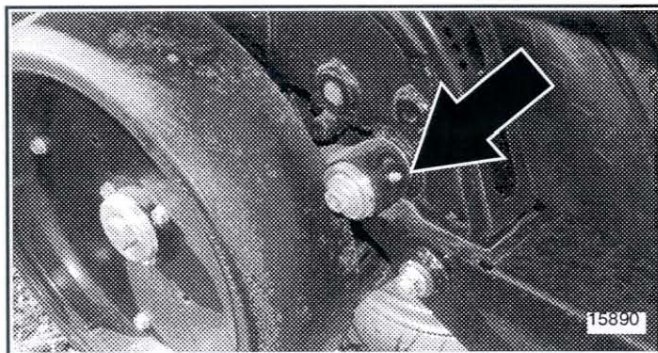
**Depth Arm Pivot**

Two grease zerks per row unit.

Type of Lubrication: Multi-Purpose Lithium Base Grease

Quantity: Until grease begins to emerge.

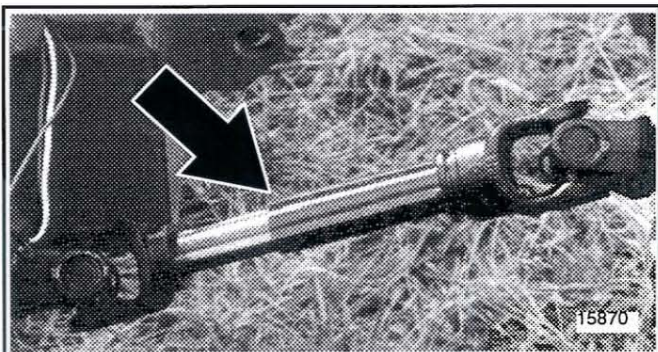
**U-joint Shaft**

Place grease on female half shaft.

Type of Lubrication: NLGI grade 2 or 3 grease lubricant.

Quantity: Coat shaft well.

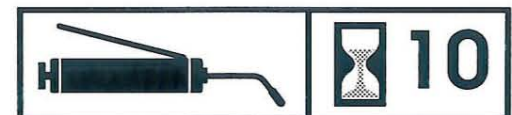
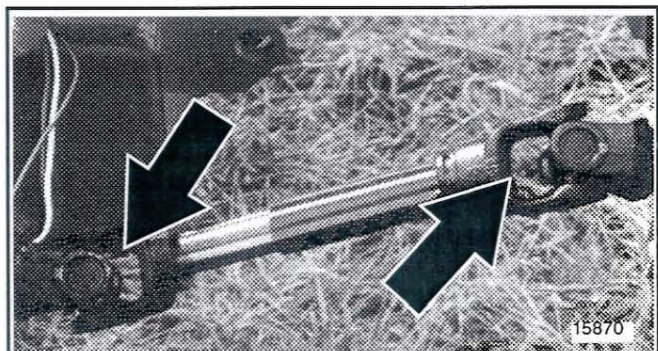
**U-joint**

One grease zerker on each end of shaft.

Type of Lubrication: NLGI grade 2 or 3 grease lubricant.

Quantity: Until grease begins to emerge.

Section 7 Maintenance and Lubrication

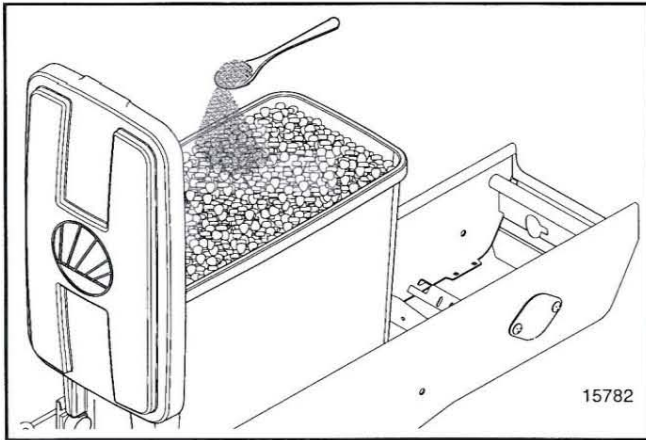

Finger Pickup Meter

To prolong the life of the finger pickup meter and increase the planting accuracy, add a teaspoon of graphite to the seeds every time you fill the hopper. Sprinkle the graphite on top of the seeds and it will filter down to lubricate the finger pickup meter.

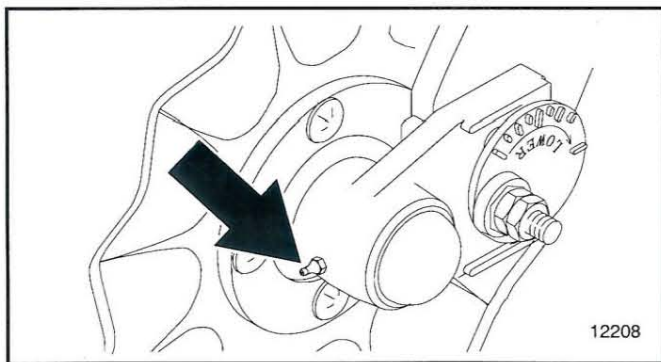

Coulter Arm Housing

The grease zerk is located on the coulters arm housing.
Type of Lubrication: NLGI grade 2 or 3 grease lubricant.

Quantity: Until grease begins to emerge.

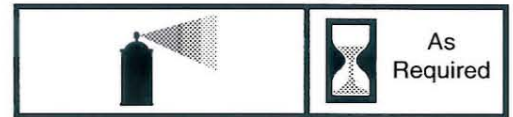
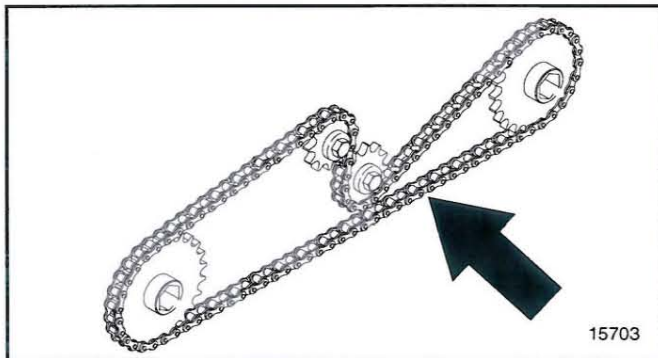

Liquid Fertilizer Chain

Lubricate all chains at intervals to maintain freedom at every chain link joint. Use a multipurpose spray lubricant on chains, because it penetrates into the rollers on the chain. Spray chains if planter is going to be idle to prevent the chains from rusting and becoming stiff. Stiff chains will cause metering inaccuracies.

Type of Lubrication: Multipurpose Chain Lube

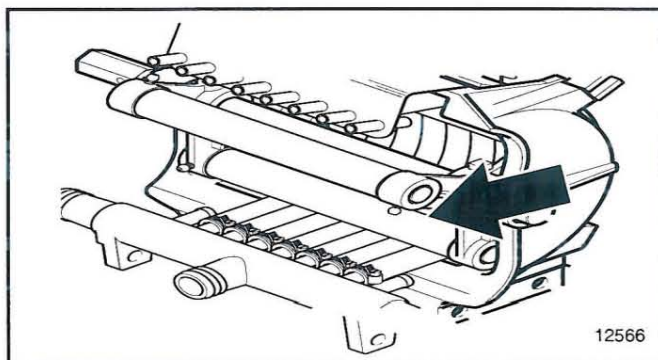

Squeeze Pump Main Metering Shaft

Located near ends of squeeze pump main metering shaft (2 total)

Type of Lubrication: Multi-Purpose Lithium Base Grease

Quantity: Until grease begins to emerge.

Section 7 Maintenance and Lubrication

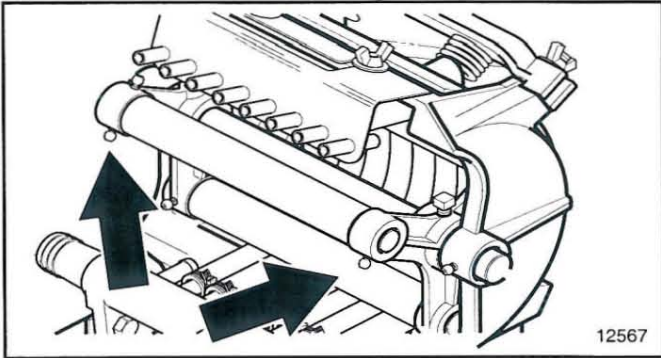
**Squeeze Pump Roller Bushings**

Located on the ends of the squeeze pump roller shafts (6 total)

Type of Lubrication: Multi-Purpose Lithium Base Grease

Quantity: Until grease begins to emerge.

Section 8 Options

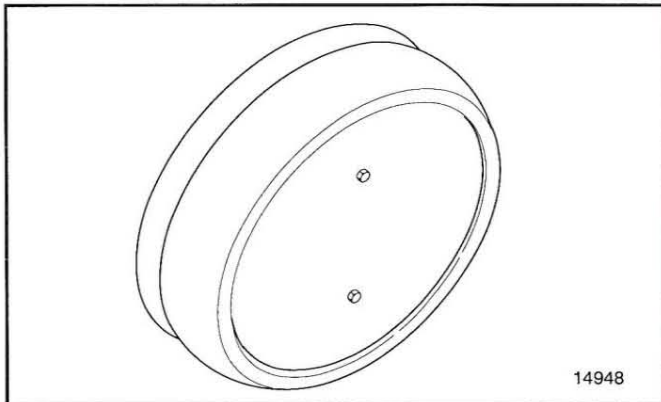

16" Wheel Cover

Helps keep soil and stones from being flipped up into the chains and sprockets.

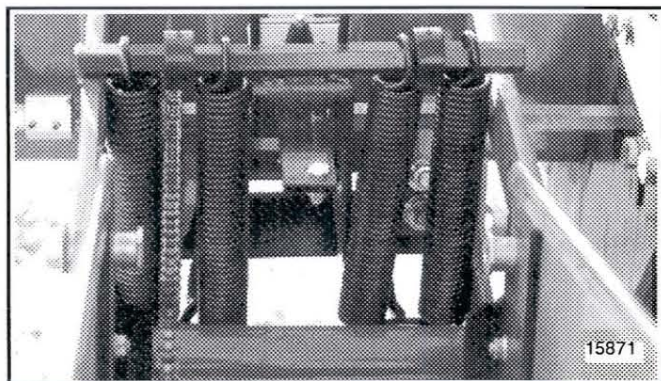

Heavy Duty Spring Package

The optional spring package enables opener down pressure to be adjusted from 100 lbs. to 400 lbs. per row.

For additional information refer to:

- "Section 4 Adjustments" on page 27
- "Section 6 Troubleshooting" on page 46

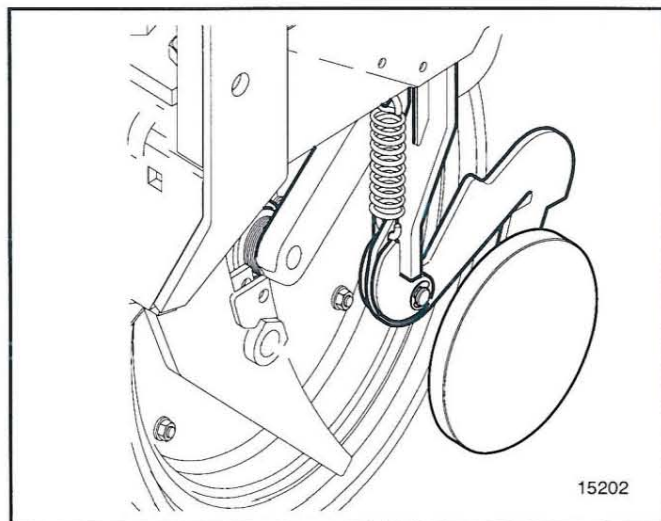

Seed Lok[®]

The optional spring loaded Seed-Lok[®] Firming wheel presses the seed directly into the bottom of the soil groove for the very best contact between soil and seed. Each seed is securely firmed into the bottom of the V-slot. The result is even emergence, since seeds are planted and firmed at the same depth.

For additional information refer to:

- "Section 4 Adjustments" on page 27

Section 8 Options

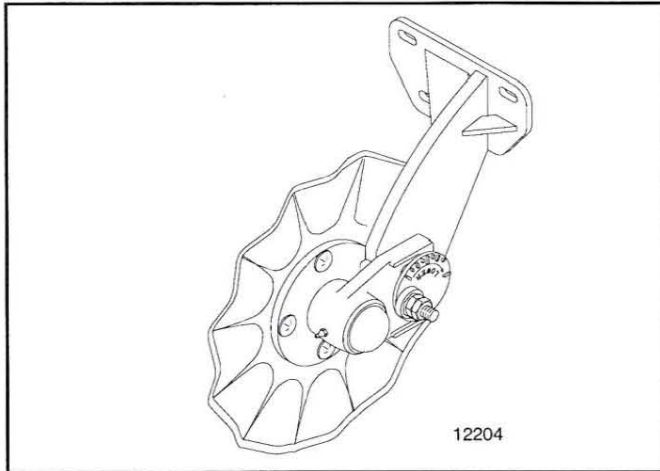

Unit Mount Coulter Option

The Unit Mount Coulter Option mounts on the row units with a cam-operated depth adjustment. The coulter tills a narrow strip immediately ahead of the openers.

For additional information refer to:

- “Section 4 Adjustments” on page 27
- “Section 7 Maintenance and Lubrication” on page 50

Coulter Bundles

3/4” Wavy Coulter

Turbo Coulter

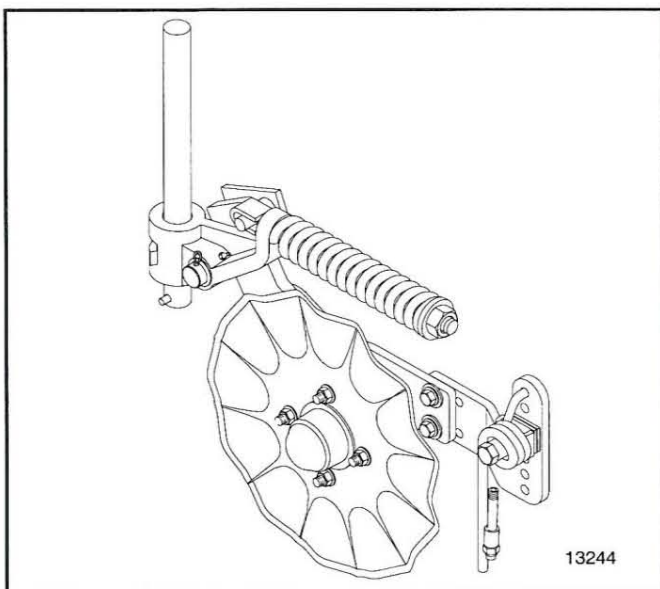

Vantage I Option

The Vantage I Option provides low pressure liquid fertilizer application. The coil tine design handles heavy residue while injecting fertilizer up to 4” deep.

For additional information refer to:

- “Section 4 Adjustments” on page 27
- “Section 7 Maintenance and Lubrication” on page 50

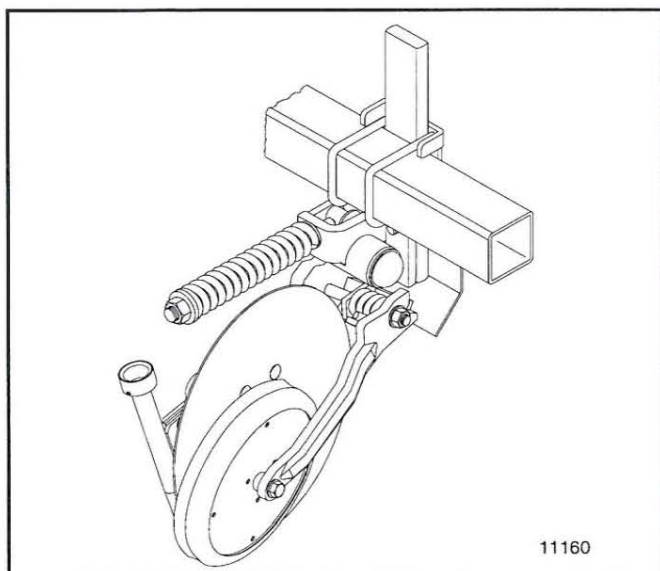

Vantage II Option

The Vantage II Option places fertilizer up to 5” deep, even in high residue no-till conditions with a minimum of soil disturbance.

For additional information refer to:

- “Section 4 Adjustments” on page 27
- “Section 7 Maintenance and Lubrication” on page 50

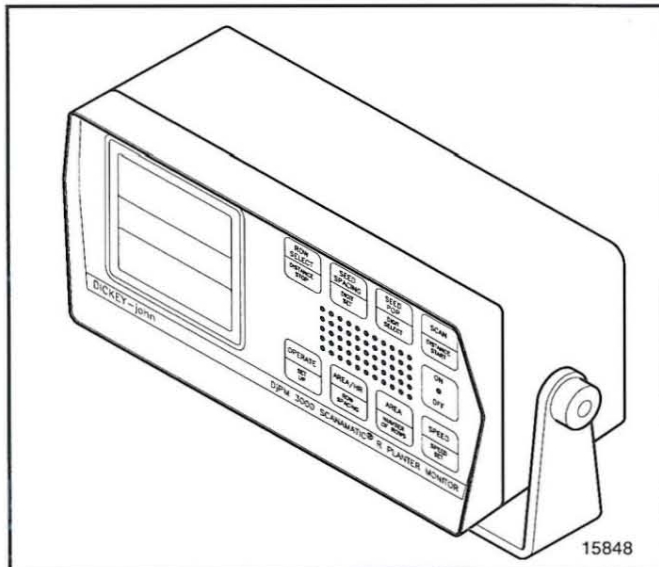
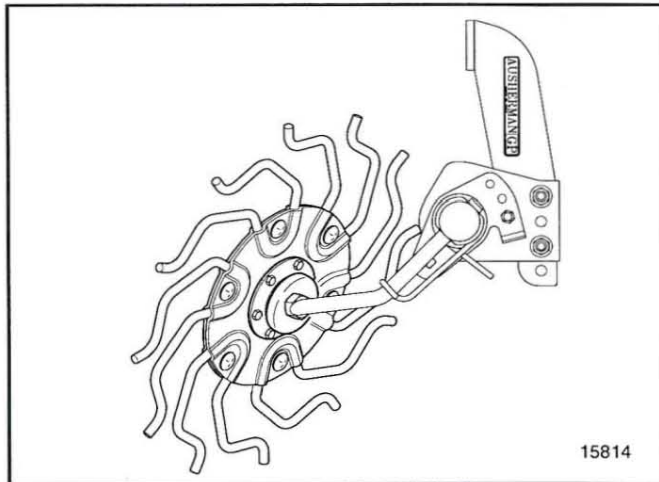
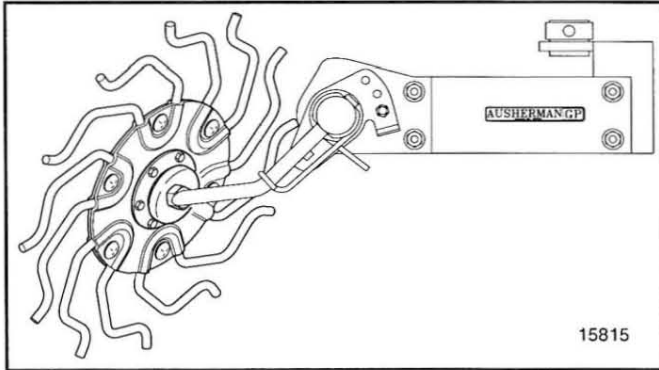

Terra Tine Option

The Terra Tine Option helps create a trash-free zone for seed placement. It works together with the fertilizer coulters or independently with very little trenching.

For additional information refer to:

- "Important Safety Information" on page 1

DICKEY-john® 1000 Monitor Option

DICKEY-john® 3000 Monitor Option

The Dickey-john® Monitor Option is a micro-processor based planter monitoring system. If seed is not going to the ground, the monitor will sound and indicate which row unit has stopped planting. The system also provides information for seed spacing, seed population, area, ground speed and the projected area/hr.

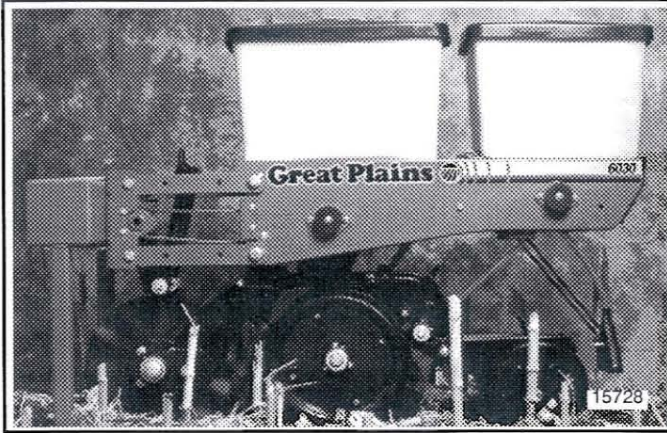

Insecticide Option

Insecticide & Herbicide Option

Chemical hoppers of 70 lbs/row capacity can be split to hold 35/35 lbs. insecticide and herbicide. Use the 7" band in front of the closing wheels or place insecticide directly in the furrow. Use the 7" or 14" band directly behind the closing wheels for herbicide application.

For additional information refer to:

- "Important Safety Information" on page 1
- "Section 3 Row Unit Operation" on page 22
- "Section 5 Planting Rate Adjustments" on page 33
- "Section 7 Maintenance and Lubrication" on page 50

Insecticide Option Bundles

1 x 12 Insecticide in Furrow

6.5 x 12 Insecticide in Furrow

1 x 12 Insecticide 7" Diffuser

Insecticide & Herbicide Option Bundles

Insecticide Furrow & Herbicide 7" 1 x 12

Insecticide Furrow & Herbicide 7" 6.5 x 12

Insecticide Furrow & Herbicide 14" 1 x 12

Insecticide Furrow & Herbicide 14" 6.5 x 12

Insecticide 7" & Herbicide 7" 1 x 12

Insecticide 7" & Herbicide 14" 1 x 12

Note: Not all Insecticide and Herbicide Options are compatible with all closing wheel options. Refer to your Great Plains dealer.

Section 9 Specifications and Capacities

Mainframe	Steel tubing, double bar 5" x 7" x 3/8" wall & 7" x 7" x 3/8" wall
Drives	Single-pitch roller chain, spring loaded tire, contact driven 2 drives (1 on each wing)
Transmission	End-mounted, No. 40 single-pitch roller chain and spring loaded ratchet idler. Interchangeable sprockets located near transmission. (1 on each wing)
Hitch	Bolt-on with adjustable clevis for leveling.
Tires	(6) 9.5L x 15 12-Ply
Transport Height	12' 10" (on top of folded markers)
Transport Width	15' 0"
Overall Length	18' 5"
Shipping Weight	11,400 lbs. (shipping weight is empty with markers)
Row Markers	Independent control, automatic alternating, 16" notched blade with depth band, cast hub with tapered roller bearings, flat fold.

Row Unit Equipment

Standard

2 bu. Seed Hopper (available w/corn meter or brush meter)

Double disk staggered Openers

4" x 16" Gauge tires

Medium Down Pressure Springs

Optional

70 lbs. Insecticide/Herbicide Hopper with 7" & 14" Diffusers

Heavy Down Pressure Springs

3/4" & Turbo Wavy Coulters

16" Wheel Covers

Seed Lok[®]

Terra Tine

Vantage I & Vantage II Fertilizer Coulters

Section 9 Specifications and Capacities

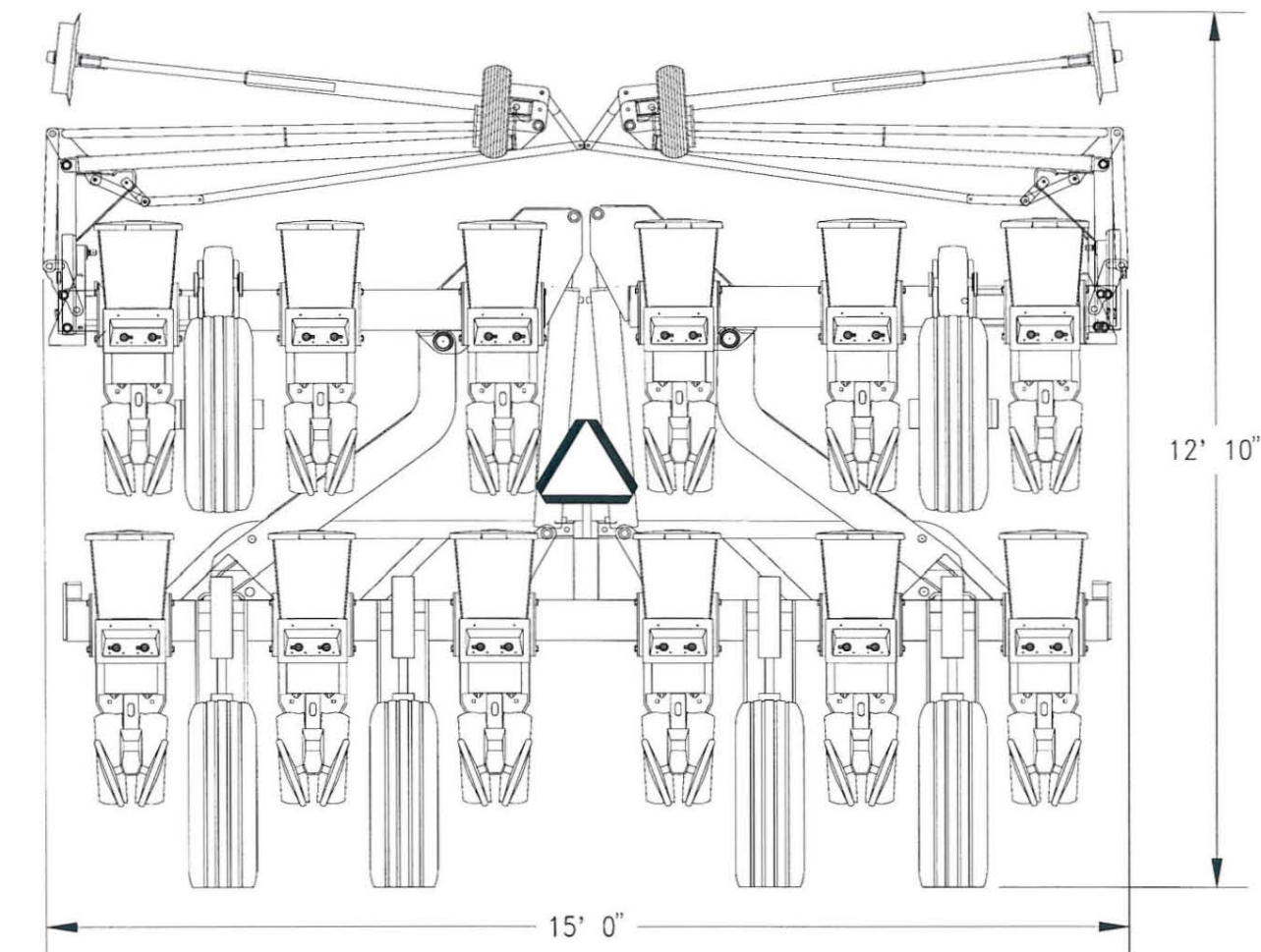

15780

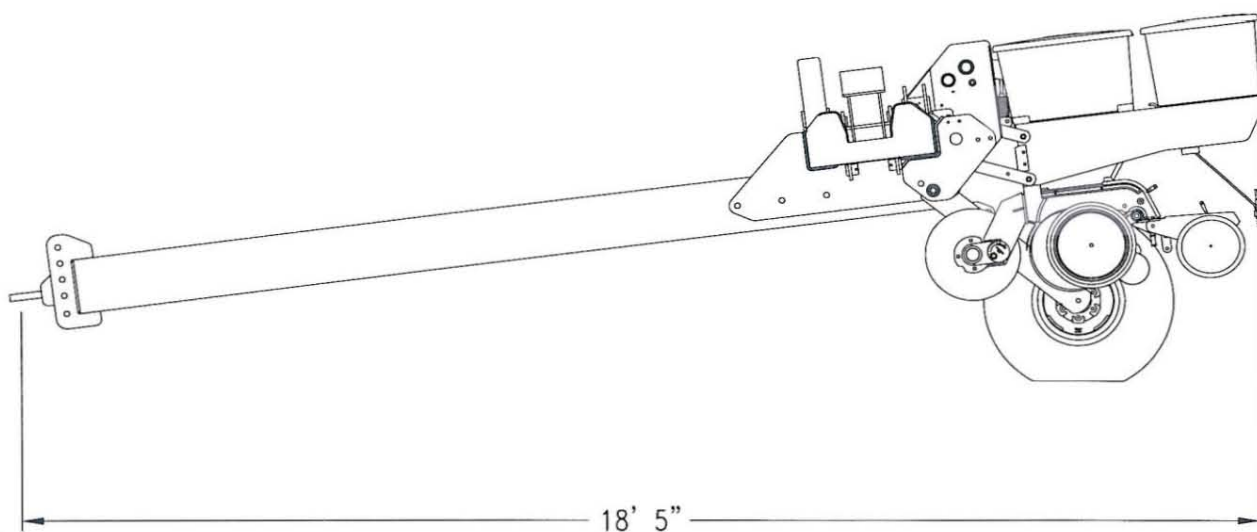







15779

Specification Drawings
Figure 9-1

Section 10 Appendix

Torque Values Chart for Common Bolt Sizes

Bolt Size (Inches) in-tpi ¹	Bolt Head Identification					
						
	Grade 2		Grade 5		Grade 8	
	N · m ²	ft-lb ³	N · m	ft-lb	N · m	ft-lb
1/4" - 20	7.4	5.6	11	8	16	12
1/4" - 28	8.5	6	13	10	18	14
5/16" - 18	15	11	24	17	33	25
5/16" - 24	17	13	26	19	37	27
3/8" - 16	27	20	42	31	59	44
3/8" - 24	31	22	47	35	67	49
7/16" - 14	43	32	67	49	95	70
7/16" - 20	49	36	75	55	105	78
1/2" - 13	66	49	105	76	145	105
1/2" - 20	75	55	115	85	165	120
9/16" - 12	95	70	150	110	210	155
9/16" - 18	105	79	165	120	235	170
5/8" - 11	130	97	205	150	285	210
5/8" - 18	150	110	230	170	325	240
3/4" - 10	235	170	360	265	510	375
3/4" - 16	260	190	405	295	570	420
7/8" - 9	225	165	585	430	820	605
7/8" - 14	250	185	640	475	905	670
1" - 8	340	250	875	645	1230	910
1" - 12	370	275	955	705	1350	995
1-1/8" - 7	480	355	1080	795	1750	1290
1 1/8" - 12	540	395	1210	890	1960	1440
1 1/4" - 7	680	500	1520	1120	2460	1820
1 1/4" - 12	750	555	1680	1240	2730	2010
1 3/8" - 6	890	655	1990	1470	3230	2380
1 3/8" - 12	1010	745	2270	1670	3680	2710
1 1/2" - 6	1180	870	2640	1950	4290	3160
1 1/2" - 12	1330	980	2970	2190	4820	3560

Bolt Size (Metric) mm x pitch ⁴	Bolt Head Identification					
						
	Class 5.8		Class 8.8		Class 10.9	
	N · m	ft-lb	N · m	ft-lb	N · m	ft-lb
M 5 X 0.8	4	3	6	5	9	7
M 6 X 1	7	5	11	8	15	11
M 8 X 1.25	17	12	26	19	36	27
M 8 X 1	18	13	28	21	39	29
M10 X 1.5	33	24	52	39	72	53
M10 X 0.75	39	29	61	45	85	62
M12 X 1.75	58	42	91	67	125	93
M12 X 1.5	60	44	95	70	130	97
M12 X 1	90	66	105	77	145	105
M14 X 2	92	68	145	105	200	150
M14 X 1.5	99	73	155	115	215	160
M16 X 2	145	105	225	165	315	230
M16 X 1.5	155	115	240	180	335	245
M18 X 2.5	195	145	310	230	405	300
M18 X 1.5	220	165	350	260	485	355
M20 X 2.5	280	205	440	325	610	450
M20 X 1.5	310	230	650	480	900	665
M24 X 3	480	355	760	560	1050	780
M24 X 2	525	390	830	610	1150	845
M30 X 3.5	960	705	1510	1120	2100	1550
M30 X 2	1060	785	1680	1240	2320	1710
M36 X 3.5	1730	1270	2650	1950	3660	2700
M36 X 2	1880	1380	2960	2190	4100	3220

¹ in-tpi = nominal thread dia. in inches-threads per inch
² N · m = newton-meters
³ ft-lb = foot pounds
⁴ mm x pitch = nominal thread dia. in millimeters x thread pitch

Torque tolerance + 0%, -15% of torquing values. Unless otherwise specified use torque values listed above.

Tire Inflation Chart

Tire Size	Inflation PSI
9.5L x 15" 12-Ply Rib Implement	60

Tire Size	Inflation PSI
13/5 x 6" 4-Ply Traction Tire	40

Great Plains Manufacturing, Inc.

Corporate Office: PO. Box 5060

Salina, Kansas 67402-5060 USA
