

**HRL35 & HR35 Retractable Series**

	<b>19" Lowback HRL3578</b>	<b>24" Highback HR3584</b>
<b>Working width</b>	78"	84"
<b>Capacity</b>	26 cu. ft.	31 cu. ft.
<b>Weight</b>	972 lbs.	1117 lbs.
<b>Weight (with hydraulics)</b>	981 lbs.	1119 lbs.
<b>Number of shanks</b>	8	8
<b>Shank material</b>	3/4" x 2 1/2" heat treated spring steel	
<b>Shank penetration</b>	3- positions (1", 3" & 5" below scraper end plates)	
<b>Shank tip construction</b>	Replaceable heat treated dimpled-on tips	
<b>Shank beam</b>	Pivots to lift shanks up; transport lock on shank tube	
<b>Lift mechanism</b>	Hydraulic cylinder	
<b>Moldboard</b>	Roll-formed moldboard - 17"	Roll-formed moldboard - 23"
<b>Side panels</b>	1/2" thick x 19" high x 30" deep	1/2" thick x 24" high x 30" deep
<b>Depth of bucket</b>	28"	27 1/2"
<b>Cutting blades</b>	2 ea. 1/2" x 6" high carbon, heat treated cutting edges; reversible and replaceable	
<b>Maximum hp rating</b>	120 hp	
<b>3-Point hitch construction</b>	Harden bushings in upper and lower hitch points	
<b>3-Point hitch type</b>	Category I & II (Quick Hitch ready)	

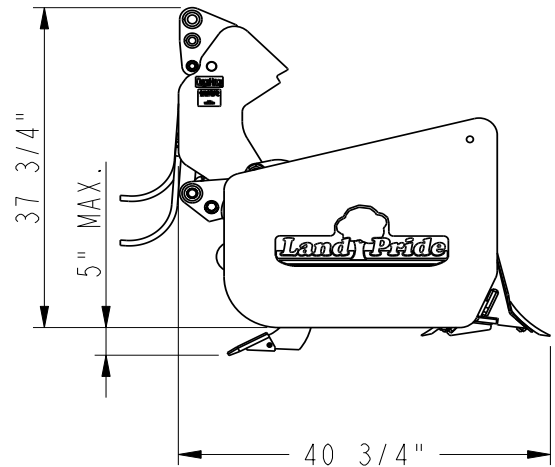
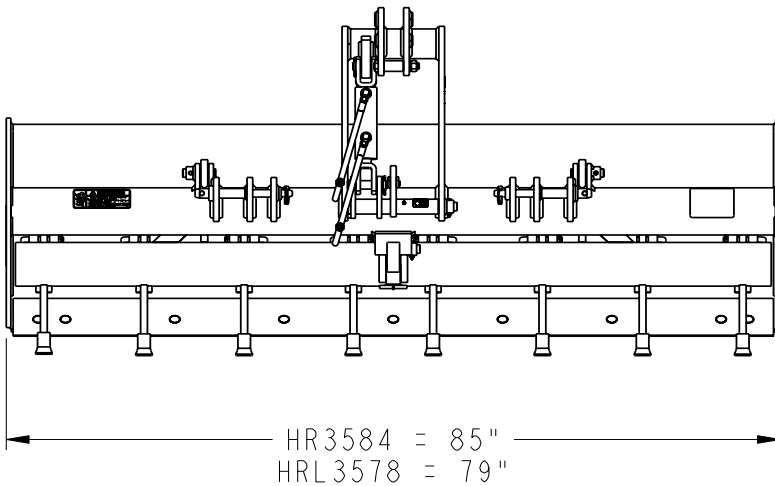

26995