

Down Pressure Kit Option Assembly Instructions



PD10/15, PD25/35 & HD25/35 Series

Manual No. 317-059M

Before You Start



When you see this symbol, the subsequent instructions and warnings are serious - follow without exception. Your life and the lives of others depend on it!

NOTE: Some tractor cabs may interfere with the Down Pressure Kit. After installation, carefully raise the post hole digger fully up with pressure cylinder fully extended to check for cab interference.

Your Down Pressure Kit is exclusively designed for Land Pride PD10, PD15, PD25, PD35, HD25 & HD35 Series Post Hole Diggers. Please read these installation instructions and your Operator's Manual thoroughly before beginning. Especially read information relating to safety concerns. Also included in the Operator's Manual is important information on operation, adjustment, troubleshooting, and maintenance for this attachment (some manual sections do not apply to all accessories).

A separate Parts Manual for replacement parts can be purchased from your dealer or available free of charge at www.landpride.com. Have model and serial numbers handy when placing an order.

Manual Part Numbers:

- PD10, PD15, PD25, PD35, HD25 & HD35 Series
Post Hole Digger Parts Manual 317-048P
- PD10, PD15, PD25 & PD35 Series
Post Hole Digger Operator's Manual 317-048M
- HD25 & HD35 Series
Post Hole Digger Operator's Manual 317-076M

General Information

These assembly instructions apply to the optional Down Pressure Kits listed below:

317-159A	PD10 Down Pressure Kit
317-027A	PD15 Down Pressure Kit
317-028A	PD25/35 & HD25/35 Down Pressure Kit

The Down Pressure Kit allows for additional digging force in hard soil conditions by use of a hydraulic cylinder and cylinder plates. Down pressure created is between 300 and 500 lbs. depending on mounting configuration.

IMPORTANT: Tractor hydraulics for operating the down pressure cylinder must have float capabilities otherwise the Post Hole Digger and Down Pressure Kit can be damaged.



WARNING!

Before making any adjustments to your Post Hole Digger, disengage PTO, shut off tractor and remove ignition key.



WARNING!

Be sure to relieve all hydraulic pressure before disconnecting any lines or pipes between the Post Hole Digger and the tractor hydraulic system.



DANGER!

Escaping hydraulic oil can have extremely high pressure. A stream of high pressure oil may easily penetrate the skin as with modern needle-less vaccination equipment - but with the exception that hydraulic fluid may cause blood poisoning.

It is imperative that all hydraulic connections are tight and that all lines and pipes are in good condition. Correct all hydraulic leaks immediately. Use a piece of cardboard or wood rather than hands when searching for hydraulic leaks. **If hydraulic fluid is injected into the skin, it must be treated by a doctor within a few hours or gangrene may result.**

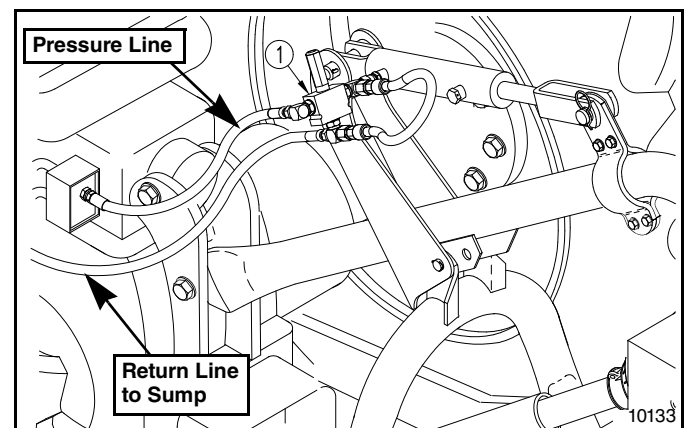

Down Pressure Kit
Figure 1

Refer to Figure 1:

IMPORTANT: Relief valve (#1) is factory set at 1500 psi. and must not be changed. Exceeding this pressure can damage the equipment.

The down pressure kit is ready for operating after it has been properly installed on the Post Hole Digger (see following pages for Assembly Instructions).

Normal digging operations are made with the tractor's hydraulic lever for the down pressure cylinder in neutral position. When encountering hard soil, move control lever in the proper direction to apply pressure and return control lever to neutral position to continue normal digging operations.

Assembly Instructions

A detailed listing of parts for each accessory kit is provided on page 6. Use the list that is for your Post Hole Digger as a checklist to inventory parts received. Please contact your local Land Pride dealer for any missing hardware.

! DANGER!

Escaping hydraulic oil can have extremely high pressure. A stream of high pressure oil can easily penetrate the skin as with modern needle-less vaccination equipment - but with the exception that hydraulic fluid can cause blood poisoning. It is imperative that all hydraulic connections are tight and that all lines and pipes are in good condition. Correct all hydraulic leaks immediately. Use a piece of cardboard or wood rather than hands when searching for hydraulic leaks. If hydraulic fluid is injected into the skin, it must be treated by a doctor within a few hours or gangrene may result.

! WARNING!

Before making any adjustments to your Post Hole Digger, disengage PTO, shut tractor off and remove key.

PD10 and PD15 Down Pressure Assembly

1. Lower Post Hole Digger until auger point is resting on the ground.

Refer to Figure 1-1:

2. At the boom and yoke connection, remove cotter pin (#2) from existing clevis pin (#1).
3. Use new pin (#3) in one end as a guide pin to remove clevis pin (#1).

NOTE: PD15 boom bracket is supplied with three mounting holes (shown) and PD10 Boom bracket is supplied with only one mounting hole (not shown).

4. Insert new clevis pin (#3) into this same location.

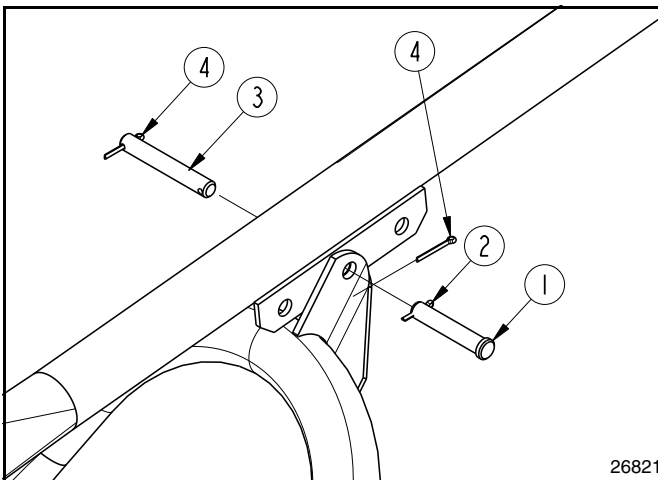

Boom/Yoke Pivot Pin Removal & Replacement
Figure 1-1

Refer to Figure 1-2:

5. Install cylinder plates (#1 & #2) with bushing tubes at the top pointing towards each other and with flat washers (#6) and cotter pins (#7) in the correct location at the bottom.
6. Install spacer (#3) between cylinder plates with 1/2"-13 x 5 1/2" GR5 bolt (#4) and lock nut (#5). Draw nut up snugly, do not tighten.

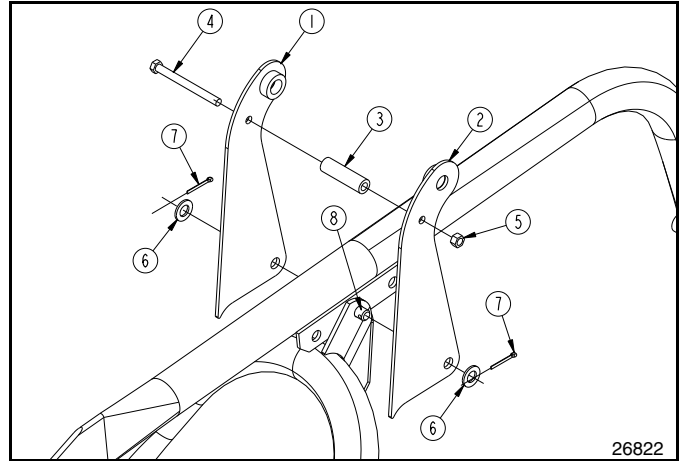

Cylinder Plate Installation
Figure 1-2

Refer to Figure 1-3:

7. Attach cylinder (#8) between cylinder plates (#1 & #2) with pin (#8). Insert both cotter pins (#7) into pin (#8) and bend one or more legs to prevent pin from falling out.
8. Torque 1/2" x 5 1/2" lg bolt (#5) to 76 ft. lbs.
9. Attach clamp plates (#3) to digger boom with 1/2"-13 x 2 1/4" GR5 bolts (#4) and lock nuts (#5). Thread nuts only one or two full turns to allow for easier attachment of down pressure cylinder (#9). Do not tighten nuts (#5) until step 16 on page 3.
10. Fully retract hydraulic cylinder (#9) and connect cylinder to clamp plates with cylinder pin (#11). Secure pin with hairpin clip (#10).

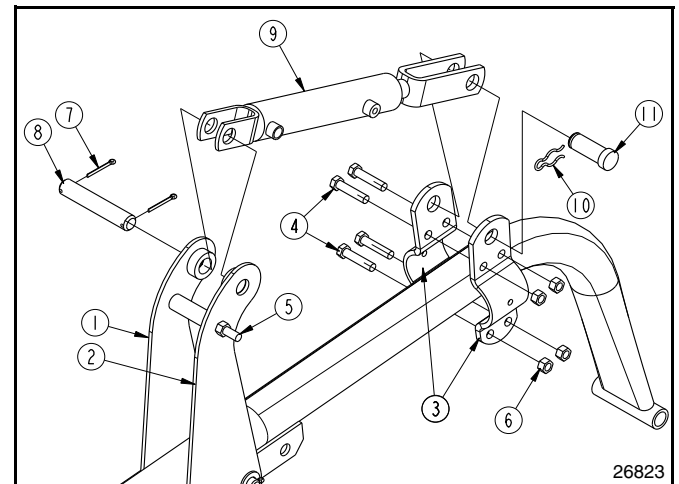

Cylinder Installation
Figure 1-3

Assembly Instructions

Refer to Figure 1-4:

11. Install hydraulic plumbing using teflon tape to seal pipe threads. Do not tighten connections until after all fittings have been installed.
 - a. Connect plug (#3) to rod end of hydraulic cylinder.
 - b. Connect straight fitting (#8) to clevis end of hydraulic cylinder.
 - c. Connect shuttle tee fitting (#9) to straight fitting.
 - d. Connect pressure relief valve (#2) to shuttle tee.
 - e. Connect standard tee fitting (#5) to the bottom end of pressure relief valve.
 - f. Connect 90° elbow fitting (#4) to remaining port of pressure relief valve.
 - g. Connect 3/8" x 15 3/4" bypass line (#7) to shuttle tee (#9) and standard tee (#5).
 - h. Connect 3/8" x 84 1/2" pressure line (#6) to 90° elbow fitting (#4).
 - i. Customer to provide return line. Connect Return line to tee fitting (#5).
 - j. Connect pressure line (#6) to tractor hydraulic outlet. Connect return line to reservoir or sump.

IMPORTANT: Do not connect return line to tractor remote outlet. Damage will occur to digger frame if not properly hooked up to reservoir or sump.

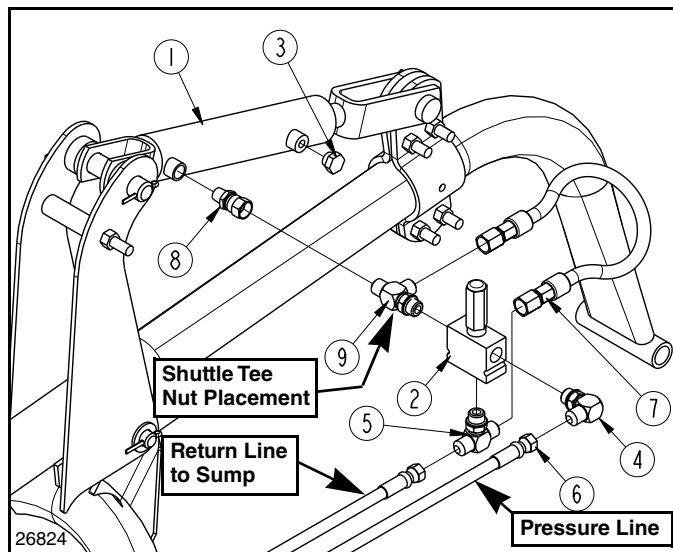

Down Pressure Cylinder Plumbing
Figure 1-4

Refer to Figure 1-5:

12. Raise Post Hole Digger so that auger tip is 6" to 12" above ground.
13. Set tractor 3-point up-stop to limit auger maximum raised height to 12". Exceeding this height can cause undue stress on PTO driveline and cause driveline damage.

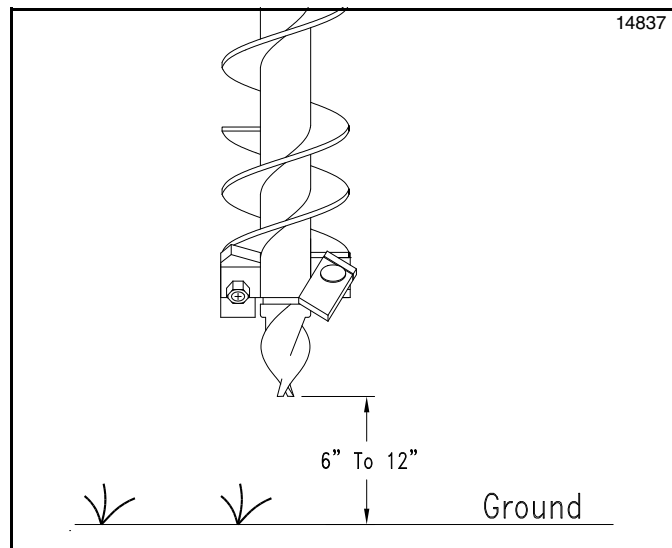

Setting Down Pressure Kit
Figure 1-5

Refer to Refer to Figure 1-6:

14. Push top of cylinder plates (#1 & #2) forward toward the tractor until plates have firmly contacted the digger yoke.
15. Make sure cylinder clamp plates (#4) will move fairly free on digger boom and that cylinder (#3) is fully retracted.
16. Extend cylinder (#3) 1/2" and tighten bolts in clamp plates (#4) evenly to 76 ft-lbs.

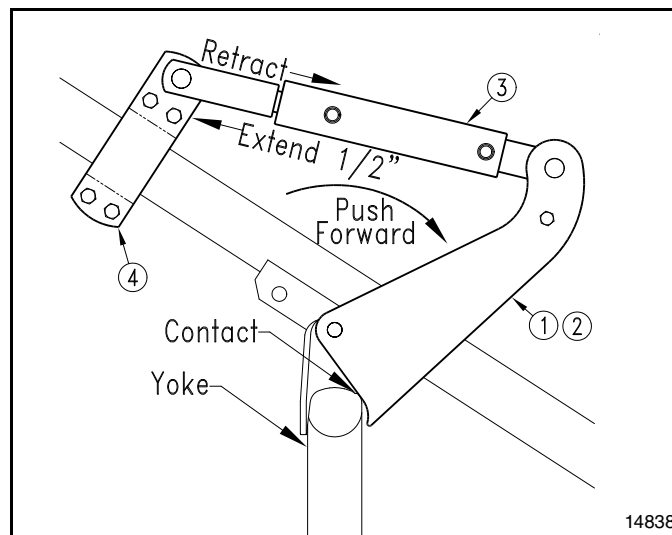

Setting Down Pressure Kit
Figure 1-6

PD25/35 & HD25/35 Down Pressure Assembly

Refer to Figure 2-1:

1. Lower Post Hole Digger unit until auger point is resting on the ground.
2. Remove cotter pins (#2) holding boom pivot pin (#3) in place.
3. Partially remove pivot pin to the right side until spacer (#1) can be removed from the left side.

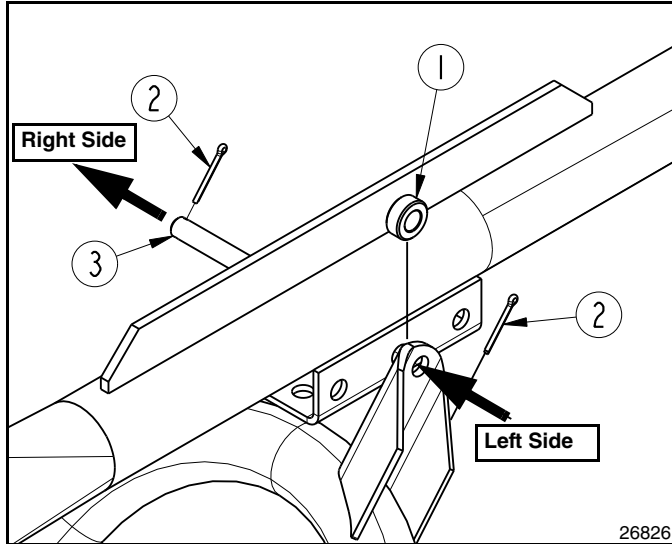

Boom/Yoke Pivot Pin & spacer Removal
Figure 2-1

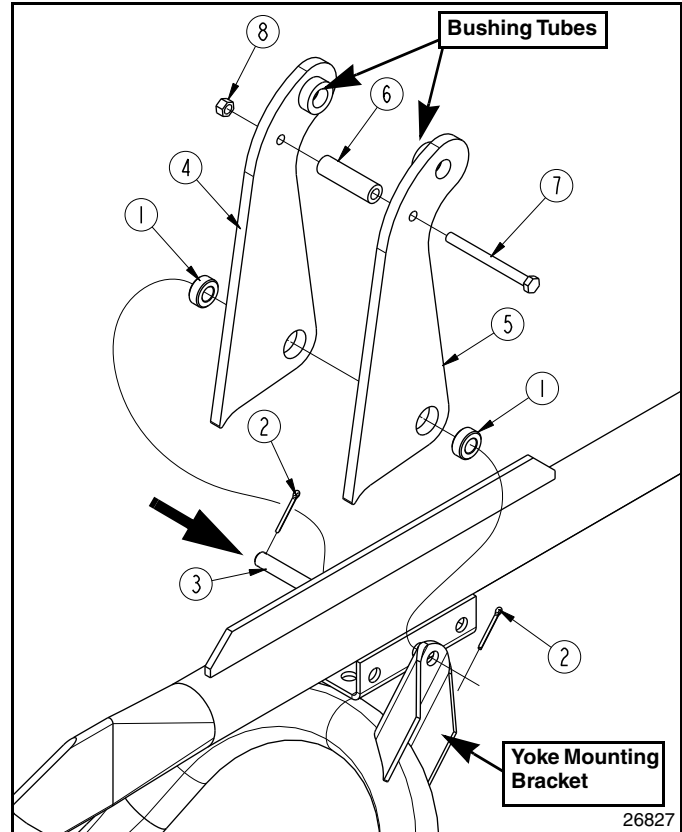

Cylinder Plate Installation
Figure 2-2

Refer to Figure 2-2:

4. Insert spacer (#1) into hole in down pressure cylinder plate (#5) located on the left side of Post Hole Digger.
5. Place left side cylinder plate with spacer back into pin position. Make sure bushing tube at the top is pointing inward as shown.
6. Push pin (#3) in until pin projects through spacer (#1) and out through yoke mounting bracket on the left side.
7. Repeat steps 3 to 6 for the right side spacer and down pressure cylinder plate (#4).
8. Install spacer (#6) between cylinder plates (#4 & 5).
9. Insert bolt (#7) through cylinder plates (#4 & 5) and spacer (#6). Draw nut up snugly, do not tighten.

Refer to Figure 2-3:

10. Attach cylinder (#9) between cylinder plates (#1 & #2) with pin (#8). Insert both cotter pins (#7) into pin (#8) and bend one or more legs to prevent pin from falling out.
11. Torque 1/2" x 5 1/2" lg bolt (#5) to 76 ft. lbs.
12. Attach clamp plates (#3) to digger boom with 1/2"-13 x 2 1/4" GR5 bolts (#4) and lock nuts (#6). Thread nuts only one or two full turns to allow for easier attachment of down pressure cylinder (#9). Do not tighten nuts (#6) until step 19 on page 5.
13. Fully retract hydraulic cylinder (#9) and connect cylinder to clamp plates with cylinder pin (#11). Secure pin with hairpin clip (#10).

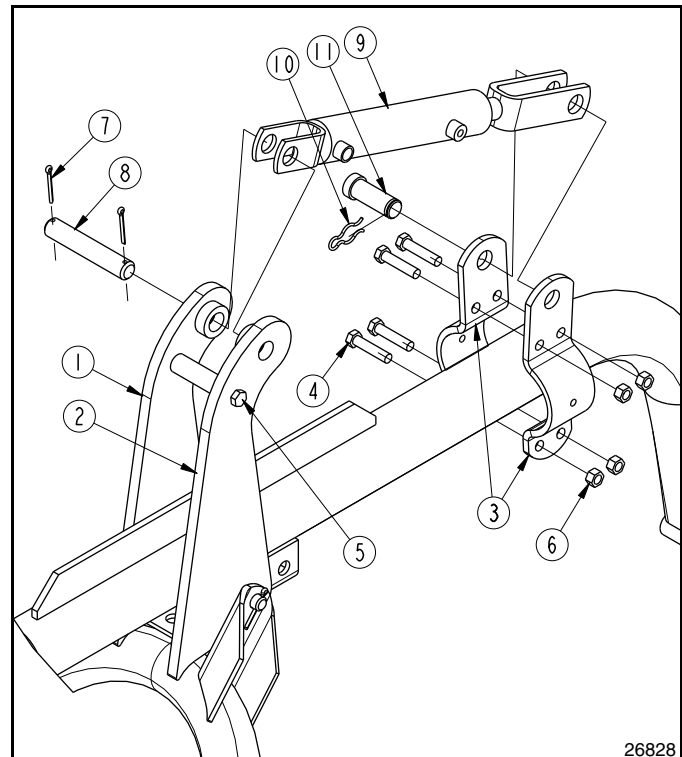

Cylinder Clamp Plate Installation
Figure 2-3

Assembly Instructions

Refer to Figure 2-4:

14. Install hydraulic plumbing using teflon tape to seal pipe threads. Do not tighten connections until after all fittings have been installed.
 - a. Connect plug (#3) to rod end of hydraulic cylinder.
 - b. Connect straight fitting (#8) to clevis end of hydraulic cylinder.
 - c. Connect shuttle tee fitting (#9) to straight fitting.
 - d. Remove 1/4" MNPT plug from bottom of relief valve (#2).
 - e. Connect pressure relief valve (#2) to shuttle tee (#9).
 - f. Connect standard tee fitting (#5) to the bottom end of pressure relief valve.
 - g. Connect 90° elbow fitting (#4) to remaining port of pressure relief valve.
 - h. Connect 3/8" x 15 3/4" bypass line (#7) to shuttle tee (#9) and standard tee (#5).
 - i. Connect 3/8" x 84 1/2" pressure line (#6) to 90° elbow fitting (#4).
 - j. Customer to provide return line. Connect Return line to tee fitting (#5).
 - k. Connect pressure line (#6) to tractor hydraulic outlet. Connect return line to reservoir or sump.

IMPORTANT: Do not connect return line to tractor remote outlet. Damage will occur to digger frame if not properly hooked up to reservoir or sump.

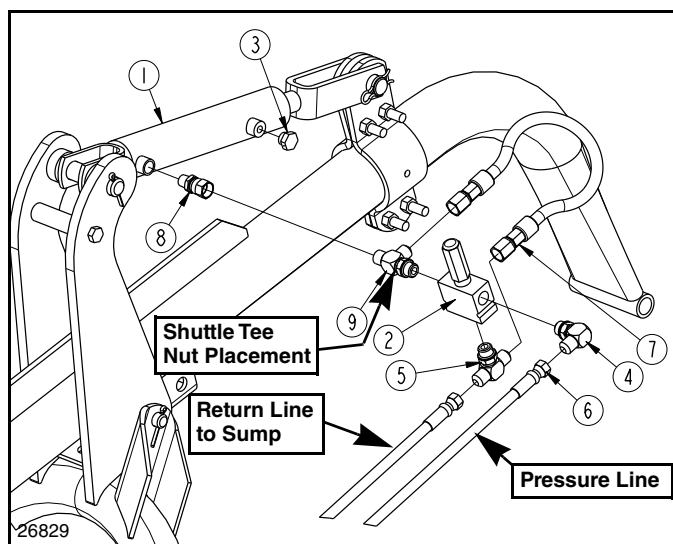

Down Pressure Cylinder Plumbing
Figure 2-4

Refer to Figure 2-5:

15. Raise Post Hole Digger so that auger tip is 6" to 12" above ground.
16. Set tractor 3-point up-stop to limit auger maximum raised height to 12". Exceeding this height can cause undue stress on PTO driveline and cause driveline damage.

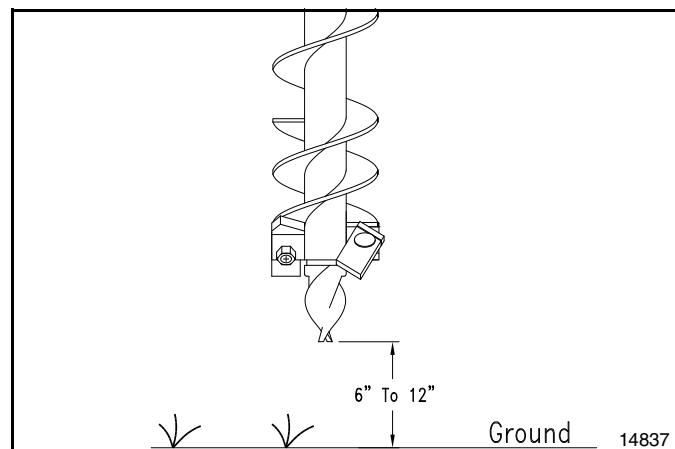

Setting Down Pressure Kit
Figure 2-5

Refer to Figure 2-6:

17. Push top of cylinder plates (#1 & #2) forward toward the tractor until plates have firmly contacted the digger yoke.
18. Make sure cylinder clamp plates (#4) will move fairly free on digger boom and that cylinder (#3) is fully retracted.
19. Extend cylinder (#3) 1/2" and tighten bolts in clamp plates (#4) evenly to 76 ft-lbs.

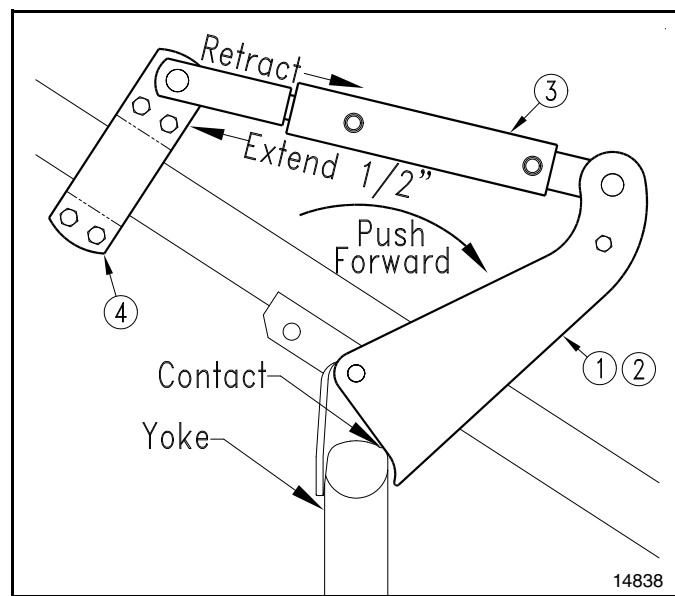

Set Down Pressure Kit
Figure 2-6

Listing of Parts

317-159A PD10 Series Post Hole Digger Down Pressure Kit

Qty.	Part No.	Part Description
1	317-026D	TUBE RD 1 X .219 WL X 3 1/2
2	317-046D	PD15 BOOM CLAMP PLATE
1	317-157H	10 DOWN PR CYL PLT WELD RH
1	317-158H	10 DOWN PR CYL PLT WELD LH
4	802-038C	HHCS 1/2-13X2 1/4 GR5
1	802-046C	HHCS 1/2-13X5 1/2 GR5
5	803-019C	NUT LOCK 1/2-13 PLT
2	804-025C	WASHER FLAT 3/4 SAE PLT
4	805-017C	PIN COTTER 3/16 X 1 3/4 PLT
1	805-229C	PIN 1 OD X 4 7/8 USEABLE
1	805-230C	PIN 3/4 X 4 13/32 USEABLE
1	810-005C	CYL 2X8X1.12 ROD
1	810-297C	VALVE RELIEF W/TAMP PROOF CART
1	811-019C	PL 3/8MNPT BREATHER
1	811-063C	EL 3/4MJIC 3/4MORB
1	811-077C	TE 3/4MORB 3/4MJIC 3/4MJIC
1	811-258C	HH3/8R2 084 1/2MNPT 3/4FJIC
1	811-949C	HH3/8R2 015 3/4FJIC
1	838-094C	DECAL WARNING HYD PRESS LONG
1	841-323C	AD 3/4FJIC 3/8MNPT
1	891-357C	TE 3/4MORB 3/4MJIC (2) SHUTTLE

317-027A PD15 Series Post Hole Digger Down Pressure Kit

Qty.	Part No.	Part Description
1	317-020H	PD15 DOWN PR CYL PLT WELD RH
1	317-021H	PD15 DOWN PR CYL PLT WELD LH
1	317-026D	TUBE RD 1 X .219 WL X 3 1/2
2	317-046D	PD15 BOOM CLAMP PLATE
4	802-038C	HHCS 1/2-13X2 1/4 GR5
1	802-046C	HHCS 1/2-13X5 1/2 GR5
5	803-019C	NUT LOCK 1/2-13 PLT
2	804-025C	WASHER FLAT 3/4 SAE PLT
4	805-017C	PIN COTTER 3/16 X 1 3/4 PLT
1	805-229C	PIN 1 OD - 4 7/8 USEABLE
1	805-230C	PIN 3/4 OD - 4 13/32 USEABLE
1	810-005C	CYL 2X8X1.12 ROD SINGLE ACTING
1	810-297C	VALVE RELIEF W/TAMP PROOF CART
1	811-019C	PLUG 3/8MNPT BREATHER
1	811-063C	EL 3/4MJIC 3/4MORB
1	811-077C	TE 3/4MORB 3/4MJIC 3/4MJIC
1	811-258C	HH3/8R2 084 1/2MNPT 3/4FJIC
1	811-949C	HH3/8R2 015 3/4FJIC
1	838-094C	DECAL WARNING HYD PRESS LONG
1	841-323C	AD 3/4FJIC 3/8MNPT
1	891-357C	TE 3/4MORB 3/4MJIC (2) SHUTTLE

317-028A PD25/35 & HD25/35 Series Post Hole Digger Down Pressure Kit

Qty.	Part No.	Part Description
1	317-022H	PD25/35 DOWN PRESS CYL PLT RH
1	317-023H	PD25/35 DOWN PRESS CYL PLT LH
1	317-026D	TUBE RD 1 X .219 WL X 3 1/2
2	317-048D	PD25/35 BOOM CLAMP PLATE
4	802-038C	HHCS 1/2-13X2 1/4 GR5
1	802-046C	HHCS 1/2-13X5 1/2 GR5
5	803-019C	NUT LOCK 1/2-13 PLT
2	805-017C	PIN COTTER 3/16 X 1 3/4 PLT
1	805-229C	PIN 1 OD - 4 7/8 USEABLE
1	810-005C	CYL 2X8X1.12 ROD SINGLE ACTING
1	810-297C	VALVE RELIEF W/TAMP PROOF CART
1	811-019C	PLUG 3/8MNPT BREATHER
1	811-063C	EL 3/4MJIC 3/4MORB
1	811-077C	TE 3/4MORB 3/4MJIC 3/4MJIC
1	811-258C	HH3/8R2 084 1/2MNPT 3/4FJIC
1	811-949C	HH3/8R2 015 3/4FJIC
1	838-094C	DECAL WARNING HYD PRESS LONG
1	841-323C	AD 3/4FJIC 3/8MNPT
1	891-357C	TE 3/4MORB 3/4MJIC (2) SHUTTLE



Corporate Office: P.O. Box 5060
Salina, Kansas 67402-5060 USA
www.landpride.com